



RHP

EBARA-ALWAYS BENEFITING THE EARTH

STEAM TYPE ABSORPTION HEAT PUMP

WWW.ERS.EBARA.COM/EN/

Cooling tower
Industrial blower
Electrical chiller/heat pump
Absorption chiller/heat pump

Absorption chiller/heat pump
Electrical chiller/heat pump
Industrial blower
Cooling tower

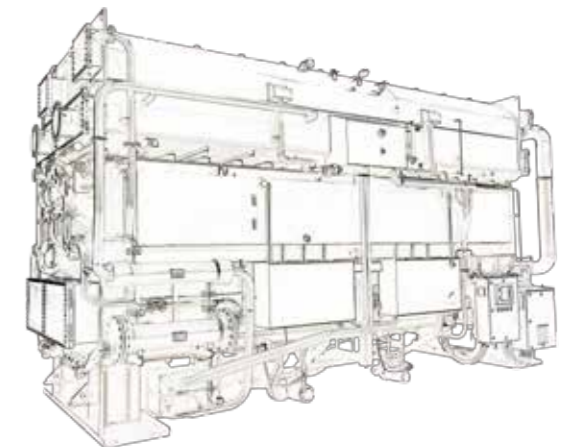

Ebara- An International Famous Brand
for Superior Environment
Friendly Products

- 03 / Company Profile
- 05 / Working Principle
- 06 / System P & I Diagram
- 07 / Product Features
- 08 / Nomenclature
- 09 / Performance Data(Partial Models)
- 11 / Dimension Drawing
- 12 / Foundation Drawing
- 13 / Requirements of Water Quality
- 14 / Installation Instruction
- 17 / Typical Application
- 18 / Job References

EBARA

COMPANY PROFILE

AN ENVIRONMENTALLY FRIENDLY COMPREHENSIVE
ENGINEERING COMPANY

Ebara All Around the World

EBARA Corporation

Ebara Corporation is one of the world's largest manufacturers of pumps, compressors, fans, heat pumps and other HVAC and refrigeration equipment. Since its establishment in 1912, Ebara Corporation has been fully dedicated to protecting the environment with a comprehensive and contemporary commitment. "Ebara-Always Benefiting the Earth" is the philosophy that guides Ebara corporate strategy.

Yantai EBARA Company Profile

Yantai Ebara Air Conditioning Equipment Co., Ltd. established in 1996, is the only overseas production base of Ebara Japan for manufacturing air conditioning equipment including absorption heat pump, centrifugal heat pump, screw heat pump, cross-flow (closed) type cooling tower, evaporative condenser, etc. Its products are exported to JAPAN and all over the world. Yantai Ebara always keeps up with the products and technology development of Ebara Japan.



PRODUCT DEVELOPMENT MILE STONES

Product Development Mile Stones



1962
Start producing absorption chiller in 1962



1967
1st double effect absorption chiller launched in 1967

1971

1st category I absorption heat pump of the world in 1971



2011

World largest absorption heat-pump 50MW in 2011

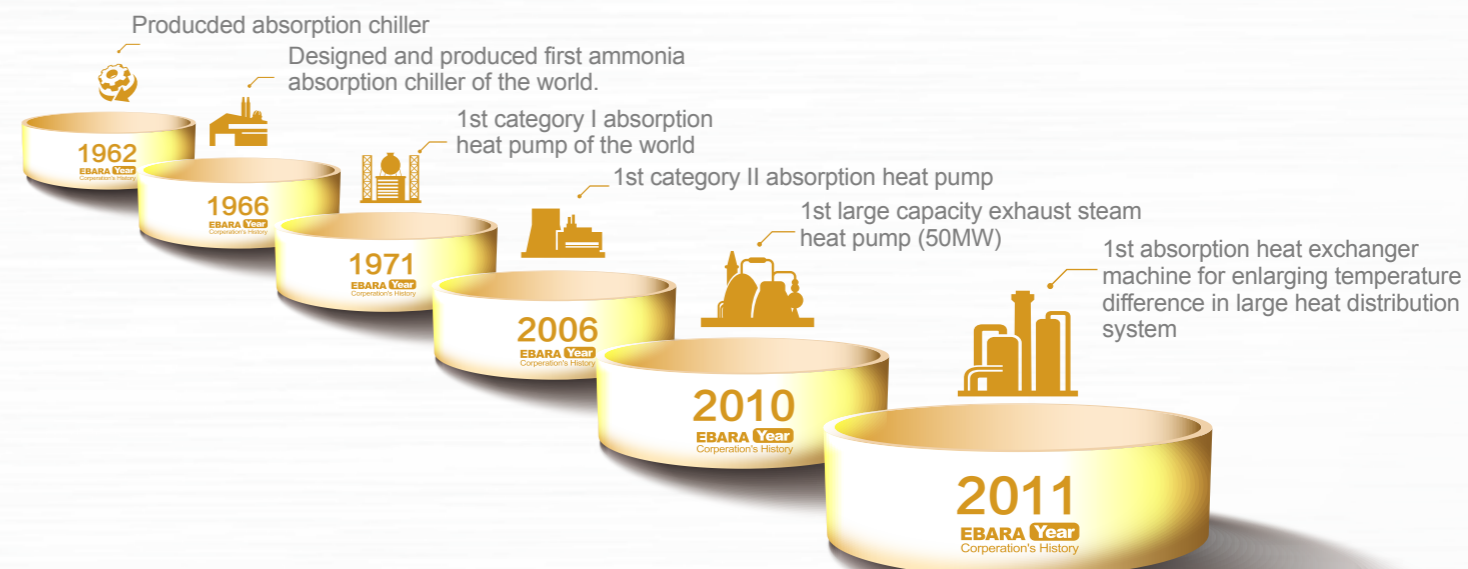

RHP SERIES FEATURES

Product Features



► RHP STEAM ABSORPTION HEAT PUMP

- Effectively Recover & Utilize Waste Heat** Utilize low temperature industrial waste heat and driven by steam to get comparatively high level heat for industrial process or district heating.
- High Efficiency** COP of Heating is 1.7, which is almost double than traditional boiler.
- High Efficiency of Heat Recovery** Equipped with plate heat exchanger in LiBr solution circuit to improve heat pump efficiency
- Wide Application** The heat pump unit is able to extract heat from 10~70℃ waste heat source and provides up to 95℃ hot water. Typically its temperature left is 40℃.
- Optimized Structure Design** Evaporator & absorber is up and down design, more compact, and avoiding pollution of refrigerant. Generator locates at top, no residual fluid at generator, easy for reflux.
- Patented Anti-crystallization Design** Adopt many refrigerant level detecting devices to avoid crystallization of solution in evaporator.
- Advanced Auto-purge System** Applied auto-purge device with new type of high reliability vacuum pump.
- Super Lower Pressure Spray Nozzle Technology** Applied Ebara patented super low pressure spray nozzle technology, better pulverization, bigger wetting surface, increase absorption efficiency.
- Environment protecting** Abolish harmful corrosion inhibitor of Lithium Chromate, the first adoption of environment protecting inhibitor Lithium Molybdate in this industry, true green product.
- Intelligent Control System** Adopt PLC control panel with touch screen, visual display of running parameters, fault record, flow chart, performance curve, etc.
- Patented High Quality LiBr Solution** Adopt Ebara patented LiBr solution, high efficiency, environment protecting, high reliability, no need regeneration, no replacement during life span.

Product Nomenclature

RHP	090	F
Series Name	Heating capacity 9000kW	S: 0.7MPa steam F: 0.5MPa steam

Performance Data

Steam pressure: 0.5MPa

Model	RHP	012F	021F	028F	036F	045F	052F	060F	070F	090F	120F	150F	180F	230F	280F		
Heating capacity	kW	1200	2100	2800	3600	4500	5200		7000	9000	12000	15000	18000	23000	28000		
Control range		20%-100% Stepless															
Hot water	Inlet/outlet temp.	°C 65 → 80															
	Flow rate	m³/h	69	120	161	206	258	298		401	516	688	860	1032	1319	1605	
	Flange connection	mm	125	150	200	200	250	250		250	250	300	400	400	450	500	
	Pressure drop	mH ₂ O	3.8	3.5	3.4	2.8	2.7	2.8		3.2	3.8	3.8	3.8	4.6	6.0	5.9	
Hot source water	Inlet/outlet temp.	°C 55 → 40															
	Flow rate	m³/h	28	49	66	84	105	122		171	220	294	367	444	567	692	
	Flange connection	mm	80	100	125	125	125	150		150	200	200	250	250	300	300	
	Pressure drop	mH ₂ O	2.6	5.4	7.6	4.8	5	5		4.7	6.0	6.0	5.9	7.7	10.1	5.2	
Steam	Steam consumption	kg/h	1086	1900	2533	3257	4072	4704		6613	8493	11287	14055	16936	21758	26561	
	Steam nozzle	mm	100	100	125	125	150	150		150	200	200	200	250	250	300	
	Drain nozzle	mm	40	40	40	50	50	50		50	65	65	80	80	100	100	
	Drain pressure	MPa	≤0.05														
	Drain temp.	°C	≤95														
Power	V*Hz*φ	380×50×3															
	Power capacity	kVA	4.5	6.2	7.6	11.4	11.4	12.8		23.9	23.9	42	43	51	63.2	69.5	
	Refrigerant pump	kW	0.3	0.4	0.4	0.8	1.1	1.1		1.5	1.5	1.5	2.2	2.2	1.5×2	2.2×2	
	Solution pump	kW	1.3	3	3	4.5	4.5	4.5		7.5	7.5	7.5×2	7.5×2	7.5×2	11×2	11×2	
	Vacuum pump	kW	0.75	0.75	0.75	0.75	0.75	0.75		0.75	0.75	0.75	0.75	0.75	0.75	0.75	
Dimension	Length	mm	3000	4025	4070	5500	5500	5500		6930	6940	7150	7150	8050	8160	9500	
	Width	mm	1550	1550	1700	1750	1950	1950		2360	2580	2990	3200	3250	3360	3600	
	Height	mm	2260	2260	2450	2500	2700	2950		3200	3500	4100	4350	4480	4750	4900	
Max. shipping weight	ton	5.1	6.5	8.1	10.5	13.9	14.2		13.6	16.8	22.7	24.9	31.5	38.6	50.7		
Operating weight	ton	6.6	8.6	11.3	13.7	16.8	17.9		29.6	39.4	48.6	55.5	64.3	76.5	95		

NOTE: Above parameters are based on conditions as below:

1. Maximum working pressure for heat pump hot water, steam and hot source water side is 0.8MPa ;
2. Fouling factor for hot water and hot source water is 0.086m²k/kW ;
3. Water quality standard is as per GB/T18431-2013 ;
4. Steam pressure is: Heat pump inlet pressure, excluding the pressure drop after steam control valve, which pressure is requested to be above 0.05MPa ;
5. Hot water and hot source water flow rate application scope: 60%~100% ;
6. Transportation:RHP070 or above is split transportation,the Max.Weight means the weight of the heaviest one ;

Performance Data

Steam pressure: 0.7MPa

Model	RHP	012S	021S	028S	036S	045S	052S	060S	070S	090S	120S	150S	180S	230S	280S		
Heating capacity	kW	1300	2300	3000	3900	4900	5700	6600	8000	10000	13000	16000	20000	24000	30000		
Control range		20%-100% Stepless															
Hot water	Inlet/outlet temp.	°C 65 → 80															
	Flow rate	m³/h	75	132	172	224	281	327	378	460	573	745	917	1147	1376	1720	
	Flange connection	mm	125	150	200	200	250	250	250	250	250	300	400	400	450	500	
	Pressure drop	mH ₂ O	4.4	4.2	3.8	3.2	3	3.2	7.2	3.9	4.5	4.2	4.2	5.5	6.1	6.5	
Hot source water	Inlet/outlet temp.	°C 55 → 40															
	Flow rate	m³/h	46	81	106	138	173	202	234	295	370	480	591	743	891	1116	
	Flange connection	mm	100	125	125	150	150	200	200	200	200	250	300	300	300	350	
	Pressure drop	mH ₂ O	6.2	4.3	6	5.4	5.8	5.5	4.3	11.8	14.3	13.6	13.0	8.7	10.2	4.1	
Steam	Steam consumption	kg/h	1162	2057	2683	3487	4383	5097	5902	7648	9556	12486	15346	19226	23120	29088	
	Steam nozzle	mm	100	100	125	125	150	150	150	150	200	200	200	250	250	300	
	Drain nozzle	mm	40	40	40	50	50	50	50	50	65	65	80	80	100	100	
	Drain pressure	MPa	≤0.05														
	Drain temp.	°C	≤95														
Power	V*Hz*φ	380×50×3															
	Power capacity	kVA	4.5	6.2	7.6	11.4	11.4	12.8	13.9	23.9	23.9	42	43	51	63.2	69.5	
	Refrigerant pump	kW	0.3	0.4	0.4	0.8	1.1	1.1	1.5	1.5	1.5	1.5	2.2	2.2	1.5×2	2.2×2	
	Solution pump	kW	1.3	3	3	4.5	4.5	4.5	7.5	7.5	7.5	7.5	7.5	7.5	11×2	11×2	
	Vacuum pump	kW	0.75	0.75	0.75	0.75	0.75	0.75	0.75	0.75	0.75	0.75	0.75	0.75	0.75	0.75	
Dimension	Length	mm	3000	4025	4070	5500	5500	5500		6930	6930	6940	7150	7150	8050	8160	9500
	Width	mm	1550	1550	1700	1750	1950	1950		2360	2580	2990	3200	3250	3360	3600	
	Height	mm	2260	2260	2450	2500	2700	2950		3200	3500	4100	4350	4480	4750	4900	
Max. shipping weight	ton	5.1	6.5	8.1	10.5	13.9	14.2	16	13.6	16.8	22.7	24.9	31.5	38.6	50.7		
Operating weight	ton	6.6	8.6	11.3	13.7	16.8	17.9	23	29.6	39.4	48.6	55.5	64.3	76.5	95		

NOTE: Above parameters are based on conditions as below:

1. Maximum working pressure for heat pump hot water, steam and hot source water side is 0.8MPa ;
2. Fouling factor for hot water and hot source water is 0.086m²k/kW ;
3. Water quality standard is as per GB/T18431-2013 ;
4. Steam pressure is: Heat pump inlet pressure, excluding the pressure drop after steam control valve, which pressure is requested to be above 0.05MPa ;
5. Hot water and hot source water flow rate application scope: 60%~100% ;
6. Transportation:RHP070 or above is split transportation,the Max.Weight means the weight of the heaviest one ;

RHP DIMENSION DRAWING

FOUNDATION DRAWING

DIMENSION DRAWING

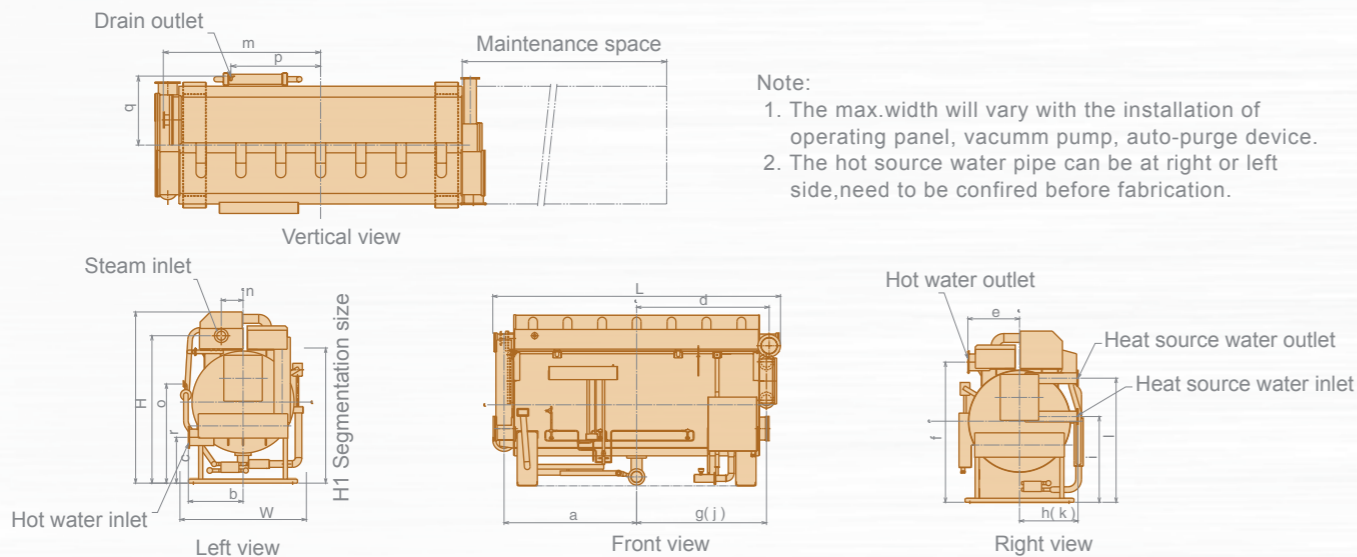

FOUNDATION DRAWING

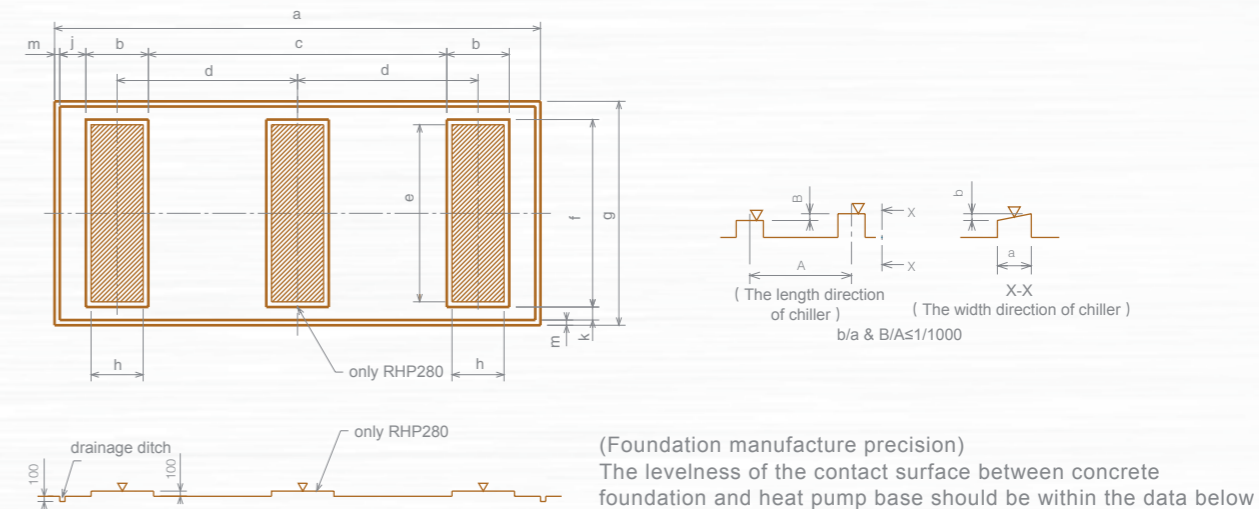

unit: mm

Item(RHP)		012	021	028	036	045	052	060	070	090	120	150	180	230	280
Hot water inlet	a	1430	2000	2000	2555	2555	2555	3320	3240	3240	3260	3285	3740	3770	4415
	b	292	292	320	320	180	225	180	985	1050	1200	1355	1450	1450	1650
	c	805	815	975	710	1095	1175	1270	835	865	1020	1136	1018	1112	1112
Hot water outlet	d	1430	2000	2000	2555	2555	2555	3320	3240	3240	3260	3285	3740	3770	4415
	e	500	350	500	500	500	510	530	1050	1100	1130	1280	1350	1450	1700
	f	1870	1870	2100	2170	2400	2580	2600	2435	2610	3170	3475	3520	3720	3850
Hot source water inlet	g	1420	2000	2005	2550	2550	2550	3315	3150	3290	3300	3215	3700	3715	4355
	h	315	315	345	345	385	400	385	970	1070	1270	1450	1450	1500	1650
	i	1050	1075	1100	1140	1260	1380	1435	1540	1600	1890	2125	2130	2135	2205
Hot source water outlet	j	1420	2000	2005	2550	2550	2550	3315	3150	3290	3300	3215	3700	3715	4355
	k	315	315	345	345	385	400	385	970	1070	1270	1450	1450	1500	1650
	l	1453	1425	1530	1540	1630	1760	1805	2140	2270	2710	3075	3090	3155	3205
Steam inlet	m	1430	2000	2000	2550	2550	2550	3320	3350	3350	3350	3380	3815	3830	4445
	n	350	350	350	320	450	450	450	410	430	600	540	550	560	560
	o	1915	1950	2150	2270	2400	2500	2550	2600	2795	3275	3655	3660	3830	3900
Condensate w. outlet	p	800	1220	1250	1560	1532	1600	2100	1800	1850	1850	1950	2500	2500	2700
	q	700	700	760	780	980	1000	860	980	1100	1250	1470	1600	1650	1700
	r	1350	1425	1500	1500	1650	1800	1830	1720	1900	2150	2520	2650	2900	3050
Split height	H1	1850	1910	2050	2140	2300	2500	2500	2460	2530	3000	3350	3350	3460	3460
Total length	L	2985	4025	4065	5245	5320	5320	6850	6930	6940	7010	7150	8065	8210	9550
Total width	W	1600	1600	1650	1670	2070	2100	1890	2300	2490	2890	3150	3250	3350	3500
Total height	H	2300	2300	2450	2450	2700	3000	2900	3200	3350	3900	4250	4435	4710	4850
Maintenance space	A	2400	3460	3460	4600	4600	4600	6100	6100	6100	6100	6100	7100	7100	8400

unit: mm

Item(RHP)		012	021	028	036	045	052	060	070	090	120	150	180	230	280
a		3305	4360	4360	5470	5470	5470	7060	7140	7120	7220	7220	8200	8200	9330
b		400	400	400	500	500	500	600	600	700	700	850	1050	1200	1200
c		1705	2760	2760	3670	3670	3670	5060	4940	4720	4720	4420	4900	4600	5730
d		1053	1580	1580	2085	2085	2085	2830	2770	2710	2710	2635	2975	2900	3465
e		1080	1180	1300	1200	1320	1400	1320	1970	2050	2370	2700	2700	3200	3400
f		1400	1500	1600	1500	1500	1600	1500	2170	2250	2570	2900	2900	3400	3600
g		2200	2300	2400	2300	2300	2400	2300	2870	2950	3270	3600	3600	4100	4300
h		150	200	200	300	300	300	380	380	500	500	650	850	1000	1000
j		300	300	300	300	300	300	300	400	400	450	450	500	500	500
k		300	300	300	300	300	300	300	250	250	250	250	250	250	250
m		100	100	100	100	100	100	100	100	100	100	100	100	100	100

RHP REFERENCE

ABOUT WATER QUALITY

REFERENCE VALUE OF WATER QUALITY

In order to keep the heat pump work effectively in long term, the water quality should be guaranteed. The data below show the reference value for hot water and hot source water. During daily operating, please manage the water quality within the reference value.

The reference value is based on GB/T18431-2013, just for reference.

Item	Hot water		Heat source water		Tendency	
	Circulating W.	Back-up W.	Circulating W.	Back-up W.	Corrosion	Fouling
PH[25°C]	7.0~8.0	7.0~8.0	6.8~8.0	6.8~8.0	—	—
Conductivity [25°C](μS/cm)	300	300	400	300	—	—
Cl ⁻ (mgCl ⁻ /L)	30	30	50	50	—	—
SO ₄ ²⁻ (mg/L)	30	30	50	50	—	—
Acid consumption [PH4.8] (mgCaCO ₃ /L)	50	50	50	50	—	—
Total hardness(mgCaCO ₃ /L)	70	70	70	70	—	—
mgCaCO ₃ /L(mgCaCO ₃ /L)	150	50	50	50	—	—
mgSiO ₂ /L(mgSiO ₂ /L)	30	30	30	30	—	—

INSTALLATION INSTRUCTION

INSTRUCTION

Foundation

- The heat pump operating weight should be evenly distributed on the contact surface of foundation.
(Please refer to dimension drawing and foundation drawing)
- Foundation must be fixed with anchor bolts. Anchor bolts and metal gaskets are optional.
- For the foundation level precision, please refer to the drawing 1 as below.
- Foundation should be waterproof, better for heat pump maintenance.
- Set the water drain gouge around the heat pump.

Transportation

- Select right size lifting crane according to the heat pump weight.
- During transportation, the heat pump should be lifted up/down horizontally.
- Please avoid collision with other objects around, especially the heat pump front side, where there are a lot of pipes and meters.
- For split lifting, please lift the part which will be installed further to the entrance.

Installization

- Select well-ventilated place as machine room, ventilation device should be installed in the machine room.
- Do not select place where is too moist or dusty, that may cause electrical failure for the heat pump, so please avoid that.
- If the heat pump installation is on the roof, please check the noise level and vibration, we recommend customer to install the anti-vibration device.
- Keep the machine room temperature in less than 40°C.
- Pay attention to the machine room lighting, convenient for regular monitoring and maintenance checking.
- Machine should be installed at place easy to drain water.
- For heat pump dimension drawing, the tolerance is +20mm, -10mm.
- Please refer to the dimension drawing and foundation drawing, and make sure there is enough space around the heat pump for maintenance (At least 1m around and 0.2m on the top) and tube drawing.
- The heat pump levelness, the shell length direction and width direction, all should be within 1/1000. (Please refer to drawing 1).
- During installation, use the steel gasket to look for a horizontal vertical degree, if anchor bolts to be installed, the anchor bolts hole should be filled by concrete to fix the anchor bolts.
- Please be sure the heat pump is far from the combustible part of the building or any combustible objects. Please follow the related regulations.

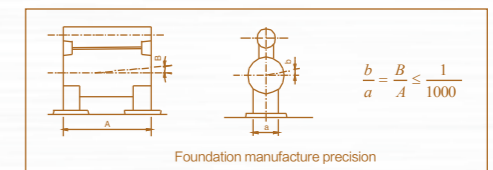

RHP INSTALLATION

INSTRUCTION

Piping works

01. Please refer to the dimension drawing for the heat source water inlet pipe direction; the standard design is at right side when we face the operating panel. If reverse, please contact Ebara before fabrication. For the flange connection location and diameter, please refer to the dimension drawing and specification.
02. For the connecting flange for hot source water and hot water, please refer to the data in the dimension drawing and prepare the right size. Flange standard: GB/T9119-2000.
03. During designing the installation position for hot source water pump, hot water pump, expansion tank, please consider the precondition of static water pressure and pump water head, the pressure exerted to heat pump, both the hot source water and hot water can't be over the Max. Working pressure. If the water pressure is over standard data, the heat pump will be special model, so please confirm the specification.
04. To keep the water flowrate stable, each heat pump should be installed with specialized hot water pump and heat source water pump.
05. Please install 10 mesh filters at the heat pump heat source water and hot water inlet.
06. Please install pressure gages and thermometers at the heat pump hot source water inlet and hot water inlet. And, in order to ensure the control stability, the hot circle water storage volume should be at least 5 times than the volume of one minute circulation.
07. Do not install any pipe for hot source water, hot water or any other water on the top of the control panel, to avoid damage to the control panel by water drop.
08. Expansion tank should be installed at the hot water circle. (Please refer to the piping diagram)
09. For hot source water and hot water piping, please set air release valve at locations above the related water box, and set the water drain valve at the lowest position of each water connection part.
10. There are air release connection plinths at the evaporator and condenser water box (Rc3/4 internal thread). Install the on/off valve to use it, and pipe it to the water drain gouge.
11. There are water release connection plinths at the evaporator and condenser water box(Rc3/4 internal thread). Install the on/off valve to use it, and pipe it to the water drain gouge.
12. Please refer to the GB/T18431-2001 standard for water quality.
13. Prepare water source for tube cleaning.
14. No load-bearing on the heat pump water flange connections, install support frame under them.
15. Install soft connecting pipe for the water connection point.
16. When water box piping at front side, in order to open the water box cover, please install short bent tube at the connection point.
17. As to the heat deformation of flange for hot source water and hot water, please consider to use the heat deformation pipe at the flange connection to eliminate the thermal stress.
18. Make sure the hot source water and hot water flange is fastened before heat insulation material installed. (The heat insulation layer should be dismountable)
19. The meters installation and the electrical wiring from heat pump to control panel should be finished before heat pump commissioning.

INSTRUCTION

Steam Piping

01. As to the steam source pressure difference, please set the steam safety valve (pressure at 0.58MPa ~0.78MPa) at the upstream of the steam control valve, the pipe to safety valve should pass to outdoor.
02. The steam reducing valve should be installed when steam source pressure is higher than the heat pump design pressure.
03. The steam temperature reducing device should be installed when steam source superheat is more than 10°C.
04. Install 80~100 mesh filters at the steam inlet.
05. Steam separator should be installed at downstream of the steam inlet pipe.
06. Install at least 1m straight pipe before or after the steam control valve, the distance from steam control valve to heat pump generator should be above 1.2 m, the horizontal pipe should be inclined to ground.
07. The steam control valve size is depends on steam inlet pressure and steam flowrate, if the steam control valve diameter is smaller than the steam pipe diameter, then variable diameter pipe should be installed.
08. Install steam pressure valve before and after the steam control valve (0~1.0MPa).
09. The by-pass valve for steam control valve is recommended, better for maintenance and repair.
10. For the steam supply system, please set main valve, which should be off during heat pump power off period, if the heat pump is remote controlled and steam main valve is still open during the heat pump power off period, then steam isolating valve should be installed.(optional part)
11. For the flange before steam go into heat pump generator, please be sure it can be fastened after heat insulation material installation and steam supply. (The heat insulation layer should be dismountable)
12. As to the heat deformation of flange for steam please consider to use the heat deformation pipe at the flange connection to eliminate the thermal stress.
13. Set the check valve and global valve for the steam condensate water outlet pipe.
14. Steam condensate return water should set open condensate water box, or closed condensate water box. No matter which way, be sure the condensate flow smoothly. Condensate water box should be 1m below the generator.
15. For the flange connecting to steam supply, please refer to the heat pump specification and prepare the right size.(For flange connection, use the flange plate)
16. The tube inside the generator is 90/10 Copper Nickle tube. If any ammonia contained in the steam, then we recommend the steel tube, which is optional.
17. Please make sure the steam condensate water is in good quality. The water quality standard is GB/T18431-2001, anything special need to handled, please inform Ebara.

RHP TYPICAL APPLICATIONS

JOB REFERENCES

TYPICAL CUSTOMERS

Renovation of Primary Station in Thermal Power Plant

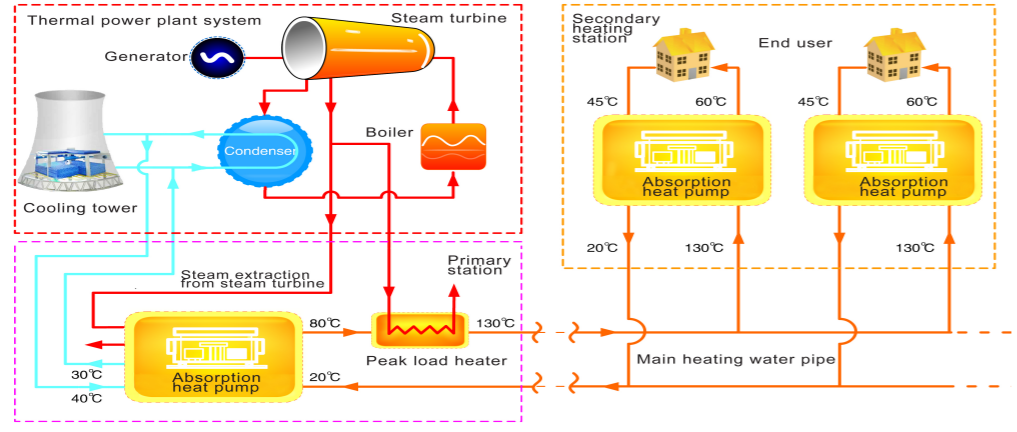

Typical Applications:

1. Diagram of first primary station after heat renovation. Energy Saving Analysis is applying absorptio technology to recover waste heat from cooling water system, recycle the waste heat from condensed steam for heating, without any additional device installed, can recycle the waste heat from condenser, and highly improve the heating area.
2. Take an example of 2 x 300MW power plants, after installing the absorption heat pump, the SO₂ emission is 2.85 million less, NO_x is 248 tons less, CO₂ is 88,000 tons less, ash emission is 8,000 tons less. It solves the problem of insufficient exhaust steam (from steam turbine) supply, reduce energy consumption and emission, improve the benefit to economy and society.

Renovation of Boiler Make Water Pre-heating

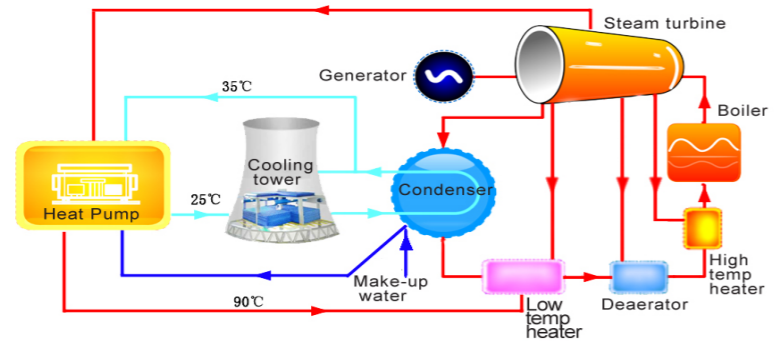

Energy Saving Analysis:

Thermal Power plant use the absorption heat pump to heat the boiler make-up water, steam is the driven energy source, the heat pump can fully recycle waste heat from the power plant recirculating water, COP is as high as 1.7. Compared with original heat exchange method, the steam consumption is 40% less, while the cooling tower water consumption is reduced.

JOB REFERENCES

