



EBARA

DOUBLE EFFECT ABSORPTION CHILLERS

MODEL REW & RGWA SERIES

**STEAM CONSUMPTION RATE : 3.9kg/(h·USRt)
: 3.95kg/(h·USRt)**

*"Model ○○○" in this catalog is our model code.



MODEL REW is;

The double effect chiller is high efficiency model,
The chiller is controlled by high performance micro

ADVANCED MICROPROCESSOR

The microprocessor as the heart of the chiller has been improved to provide even better performance, enabling ideal operation control and operation information management.

1. Quick startup for energy saving

The time from operation start to actual running has been reduced by optimizing the amount of solution circulating at the operation start. This also saves energy at startup.

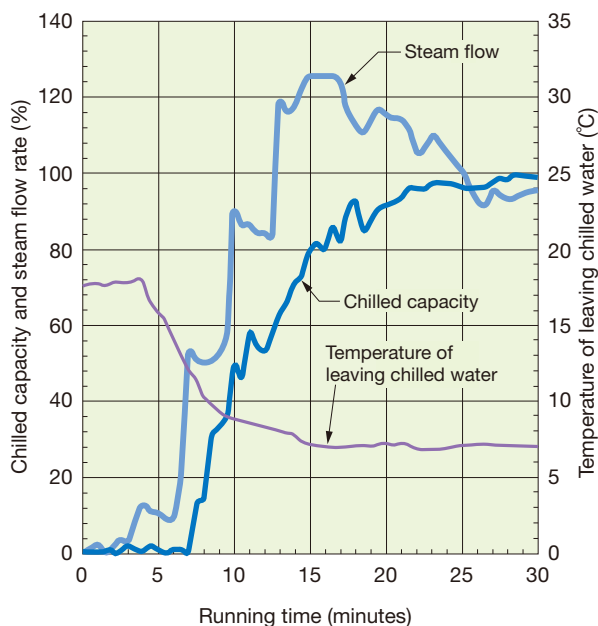

2. Reduced dilution time at shutdown

The minimum diluting time is decided according to the operation status at shutdown. Over-dilution is thus avoided and energy conserved.

3. Interlocking circuits of auxiliary devices as standard

Interlocking circuits are provided as standard for the pumps of the chilled water and cooling water and for the fan of the cooling tower. Also, the start-stop circuit of the cooling tower fan houses a temperature sensor as standard, for reduced initial costs.

4. Digital display of operation status

The control panel displays information required for operation management, such as the temperature of the chilled water, the cooling water, and the solution.

- Outlet temp. of high temp. generator
- Inlet temp. of high temp. generator
- Condensation temp. of high temp. generator
- Chiller on-off times
- Temp. of leaving/entering chilled water
- Temp. of leaving/entering cooling water
- Chiller running time
- Running time of refrigerant pump
- Running time of solution pump
- Refrigerant evaporating temp.
- Refrigerant condensing temp.
- Absorber solution temp.
- Valve opening position
- Solution pump running time
- Refrigerant pump running time

5. Failure recovery function

The chiller's sensors constantly monitor the operating status and condition. The automatic failure reconvert function can remedy many abnormalities, thus minimizing stoppages owing to failures.

- Dew point control for high temp. generator
- Solution temperature control for high temp. generator
- High temperature generator keeping below ambient control

6. Pre-alarm system for preventive maintenance

The pre-alarm system gives advance notice about maintenance information, such as fouling in cooling water tubes and the time for replacing parts.

- Rise in LTD of cooling water
- Purge pump overload
- Replacement time for parts
- Abnormalities in level control of high temp. generator
- Rise in internal pressure
- Abnormalities indicated by temperature sensor (7-segment indication)
- Rise in temperature of entering cooling water
- Rise in concentration of solution in high temp. generator
- Rise in condensation temperature of high temp. generator
- Rise in temperature of solution of generators

7. Instantaneous power-failure recovery circuit as standard

As standard, the chiller contains an instantaneous power failure recovery circuit. An optional circuit is also available for power failures lasting up to 10 minutes. The circuitry enables the chiller to start automatically once power is recovered. However, this requires equipment to cut off the steam at power failure. When a power failure lasts longer than 10 minutes, a safety shutdown occurs.

which steam consumption rate is 3.9kg/(h·USRt) processor

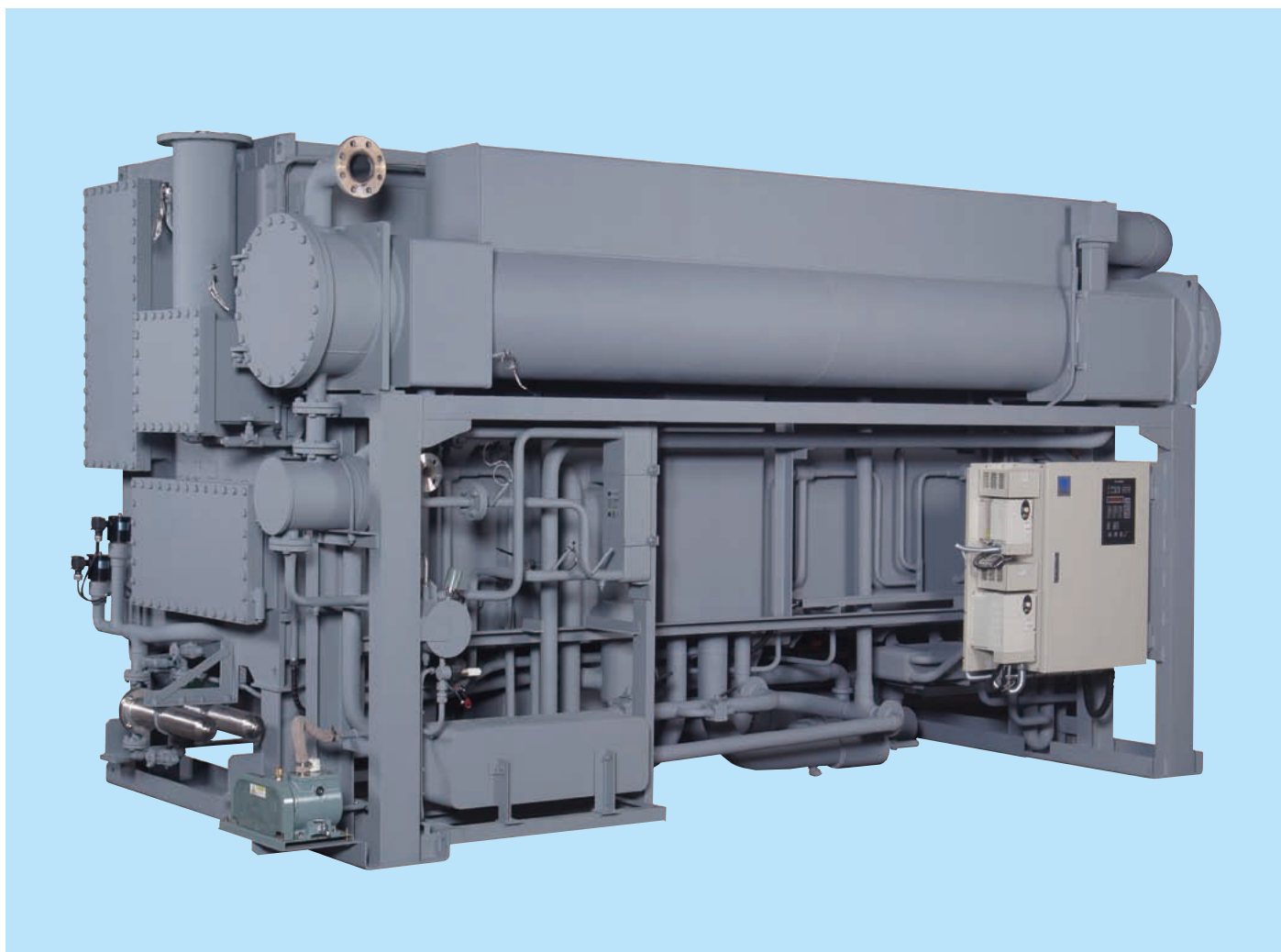

Steam drain outlet temperature below 90°C, thus saving energy.

The steam drain is cooled down below 90°C, to prevent flushing at the drain outlet. Further, the drain trap is factory mounted to the chiller, thus reducing installation costs.

Excess steam start up consumption prevention

The steam valve is set to slow start to prevent excessive consumption of steam at cold start. Also, the operation system of the boiler minimizes problems.

No manual purge is required by Automatic Purge Unit

While the chiller is running, the ejector uses the discharge pressure of the solution pump to continuously feed noncondensables (hydrogen generated in the chiller and air leaked from outside) to the purge tank, thus keeping the inside of the chiller clean. Noncondensable gas and hydrogen gas accumulated in the purge tank is automatically discharged outside via the auto purge unit. This auto purge unit eliminates the need to purge hydrogen gas, and noncondensable, for ordinary air-conditioning purposes.

Marine-type water boxes as standard.

To facilitate tube inspection and cleaning, a marine-type water box is provided as standard for the chilled and cooling water system. Also, the cover of the water box is hinged so that tubes can be cleaned easily at the jobsite.

MODEL : REW

MODEL		REW015	REW018	REW021	REW025	REW028	REW032	REW036	REW040	REW045	
COOLING CAPACITY	kW	527	634	738	880	985	1,126	1,267	1,407	1,582	
	USRt	150	180	210	250	280	320	360	400	450	
CHILLED WATER	Temperature	°C 12 → 7									
	Flow Rate	L/min	1,510	1,810	2,120	2,520	2,820	3,230	3,630	4,030	4,540
	Press. Drop	kPa	81	81	77	81	72	72	74	75	70
	Connection Size	mm	100	100	125	125	150	150	150	150	200
	Pass	—	4	4	4	4	3	3	3	3	3
COOLING WATER	Temperature	°C 32 → 37.3									
	Flow Rate	L/min	2,500	3,000	3,500	4,170	4,670	5,330	6,000	6,670	7,500
	Press. Drop	kPa	89	99	91	98	81	84	87	90	83
	Connection Size	mm	125	125	150	150	200	200	200	200	250
	Pass	—	3+1	3+1	3+1	3+1	3+1	2+1	2+1	2+1	2+1
STEAM	Consumption	kg/h	585	702	819	975	1,092	1,248	1,404	1,560	1,755
	Steam Connection	mm	50	50	65	65	65	65	65	80	80
	Drain Connection	mm	25	25	25	25	25	25	25	25	25
ELECTRICITY POWER	Power Source	V×Hz	200×50/60, 220×60, 380×50/60, 400×50, 440×60								
	Power Capacity	kVA	8.5	8.7	10.1	12.6	12.7	12.7	13.1	14.5	14.7
	Refrigerant Pump	kW	0.15	0.15	0.3	0.3	0.3	0.3	0.4	0.4	0.4
	Solution Pump	kW	2.2	2.2	2.2	3.2	3.2	3.2	3.2	3.7	3.7
	Spray Pump	kW	1.1	1.1	1.8	1.8	1.8	1.8	1.8	3.0	3.0
DIMENSION WEIGHT	Length	mm	3,570	3,570	3,600	3,585	4,680	4,660	4,720	4,700	4,820
	Width	mm	1,720	1,815	1,880	1,990	1,950	1,960	2,150	2,160	2,255
	Height	mm	1,900	1,940	2,050	2,160	2,100	2,170	2,250	2,340	2,480
	Dry Weight	t	6.9	7.4	8.1	8.8	10.8	11.5	12.8	14.8	15.6
	Operating Weight	t	7.4	8.0	8.8	9.6	11.8	12.7	14.0	16.2	17.2

SCOPE OF SUPPLY

Supply Portion: ○ : Ebara × : Purchaser

Item	Scope of Supply	Remarks	Item	Scope of Supply	Remarks
Chiller	○	Connecting piping between absorber and condenser is not required. Amount for initial charging Airtightness test only Tie point is FOB Yokohama or Tokyo port	External pipework	×	Companion-flanges not included.
Control panel	○		External wiring	×	Interlock wiring not included.
System wiring and pipework	○		Final coat of paint on chiller	×	Control panel installed at site.
Absorber solution and refrigerant	○		Insulation work for chiller	×	For chilled water and cooling water
Factory test	○		Factory witnessed test	×	
Transportation	○	Cooling water temperature control	×		
Supervision of installation at site	×	(as option) (Note 1)	Thermometers, pressure gauges	×	Three copies Spares
Fixing anchor bolts	×		Flow meter	×	
Protection during conveyance	×		Drain valve, air vent valve	×	
Disposal of packing materials	×		Anchor bolts	×	
Nitrogen gas for storage	×		Instruction manual	○	
Commissioning Supervision	×	(as option) (Note 1, Note 2)	Fuses	○	
Foundation work	×				

Notes:

- Please be ready to supply water, electricity, gas and consumables required for installation, test operation and adjustment at supervision.
- If the temperature of the entering cooling water decreases to 15°C or lower, the temperature of the cooling water must be controlled.
The ON-OFF control circuit for the cooling tower fan is provided as standard (including thermal sensor).

MODEL : REW & RGWA

MODEL		REW050	REW056	REW063	REW070	RGWA083	RGWA100	RGWA120	RGWA135	RGWA150	
COOLING CAPACITY	kW	1,758	1,970	2,216	2,462	2,919	3,516	4,220	4,747	5,274	
	USRt	500	560	630	700	830	1,000	1,200	1,350	1,500	
CHILLED WATER	Temperature	°C 12 → 7									
	Flow Rate	L/min	5,040	5,640	6,350	7,060	8,370	10,080	12,100	13,610	15,120
	Press. Drop	kPa	70	54	73	95	74	79	74	77	80
	Connection Size	mm	200	200	200	200	250	250	300	300	300
	Pass	—	3	3	3	3	2	2	2	2	2
COOLING WATER	Temperature	°C 32 → 37.3				32 → 37.5					
	Flow Rate	L/min	8,340	9,340	10,500	11,670	13,610	16,400	198,680	22,140	24,600
	Press. Drop	kPa	85	55	73	94	98	98	105	98	102
	Connection Size	mm	250	250	250	250	300	350	350	400	400
	Pass	—	2+1	2+1	2+1	2+1	2+1	2+1	2+1	2+1	2+1
STEAM	Consumption	kg/h	1,950	2,184	2,457	2,730	3,279	3,950	4,740	5,333	5,925
	Steam Connection	mm	80	80	100	100	100	100	125	125	125
	Drain Connection	mm	25	25	40	40	40	50	50	50	50
ELECTRICITY POWER	Power Source	V×Hz	200×50/60, 220×60, 380×50/60, 400×50, 440×60								
	Power Capacity	kVA	14.7	15.9	15.9	15.9	28.2	28.8	32.2	37.8	37.8
	Refrigerant Pump	kW	0.4	0.4	0.4	0.4	1.1	1.5	1.5	1.5	1.5
	Solution Pump	kW	3.7	5.5	5.5	5.5	3.7+3	3.7+3	3.7+3.7	4.5+3.7	4.5+3.7
	Spray Pump	kW	3.0	3.0	3.0	3.0	2.2+3.7	2.2+3.7	3.7+3.7	3.7+4.5	3.7+4.5
DIMENSION WEIGHT	Length	mm	4,820	5,350	5,870	6,330	7,150	7,125	7,200	7,300	7,300
	Width	mm	2,310	2,670	2,670	2,670	2,720	2,960	2,960	3,260	3,450
	Height	mm	2,550	2,945	2,945	2,945	3,210	3,350	3,610	3,740	3,875
	Dry Weight	t	17.3	21.8	22.8	24.4	23	25.7	28.5	31.8	34.8
	Operating Weight	t	19.2	23.9	25.0	26.8	32.1	36.6	41.2	45.9	50.0

Notes:

1. Supply steam pressure is 0.78MPa. If steam pressure or temperature (185°C) is over our design, steam pressure and/or temperature shall be reduce it.
2. Water boxes design pressure is 0.78MPa for both chilled & cooling water. Design fouling factor is 0.086m²/K/kW.
3. Steam condensate is lower than 90°C and pressure is 49kPa.
4. Chiller's performance & mechanical performance is designed in accordance with JIS B 8622.
5. Please use clean water for both chilled and cooling water, which shall be followed JRA GL-02-1944 standard indicated below.

Quality standard for cooling water

For efficient operation of the unit for a long term, the water quality control is necessary. The following table shows a quality guideline of the cooling water complied with Japan Refrigeration and Air conditioning Association. (JRA GL-02-1994)

	Item	Cooling water system		Tendencies	
		Circulating water		Corrosion	Scale/Slime
		Circulating water	Make-up water		
Standard items	pH (25°C)	6.5~8.2	6.0~8.0	○	○
	Electric conductivity (25°C) (mS/m)	80 or less	30 or less	○	○
	Chloride ions (mg-Cl ⁻ /L)	200 or less	50 or less	○	
	Sulfate ions (mg-SO ₄ ²⁻ /L)	200 or less	50 or less	○	
	Acid consumption (pH4.8) (mg-CaCO ₃ /L)	100 or less	50 or less		○
	Total hardness (mg-CaCO ₃ /L)	200 or less	70 or less		○
	Calcium hardness (mg-CaCO ₃ /L)	150 or less	50 or less		○
	Ionized silica (mg-SiO ₂ /L)	50 or less	30 or less		○

Note: As the JRA standard, other items are also listed for your reference.

CYCLE FLOW & PIPING FLOW

Refrigeration Cycle

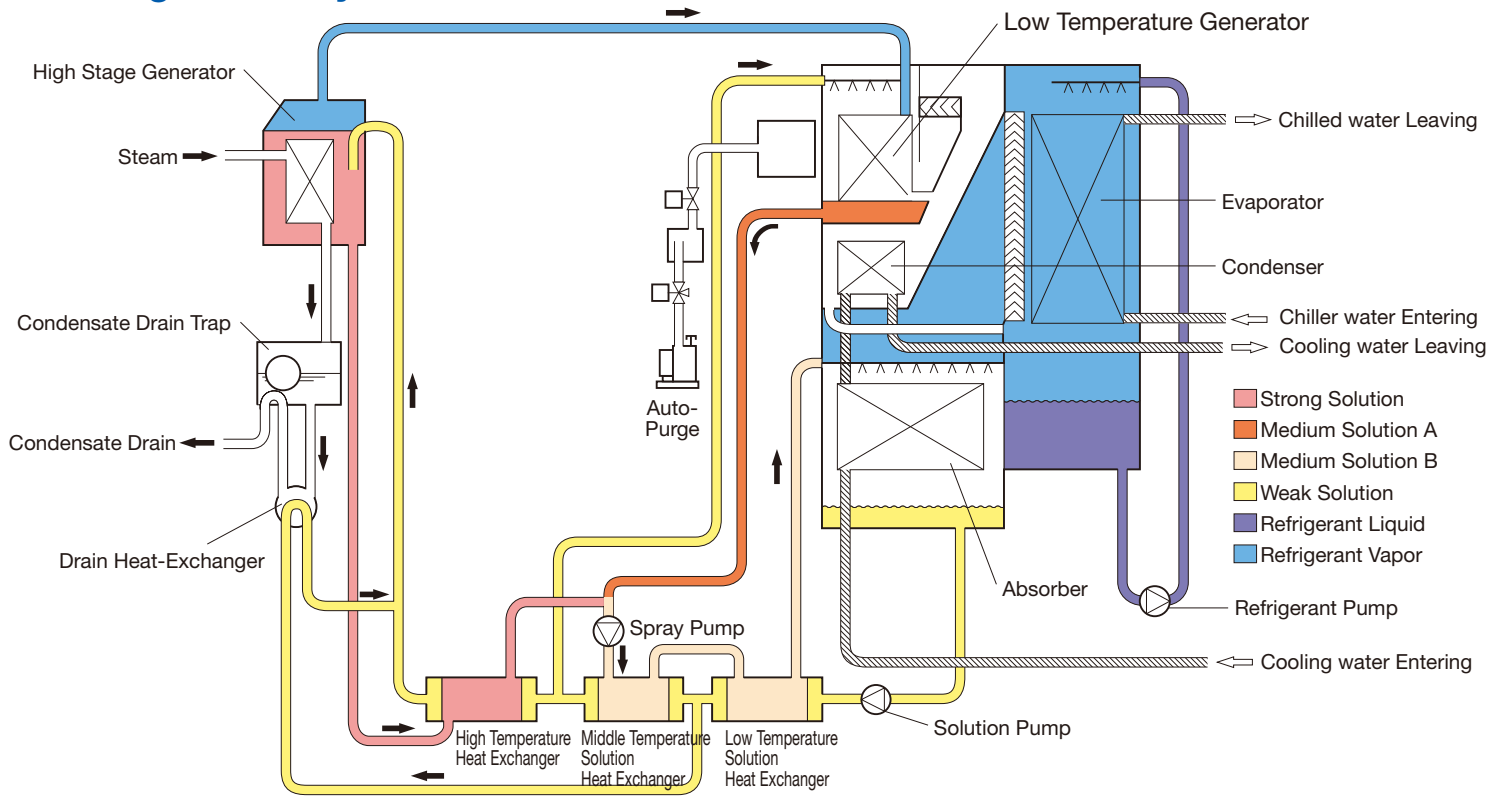

Refrigerant is vaporized and chilled the chilled water in the evaporator. Vaporized refrigerant is absorbed by strong solution in the absorber. Refrigerant absorbed strong solution become weak. Weak solution cannot absorb refrigerant anymore. The weak solution is send to low stage generator and heated and partially concentrated. Weak solution is send to high stage generator and heated by steam and become strong. Strong solution is come back to absorber mixed with intermediate solution. Separated refrigerant vapor is heating lowstage generator solution and condensed. Condensed refrigerant & separated refrigerant is cooled by cooling water in the condenser and become water refrigerant and come back to evaporator and vaporized again.

Piping Flow Diagram

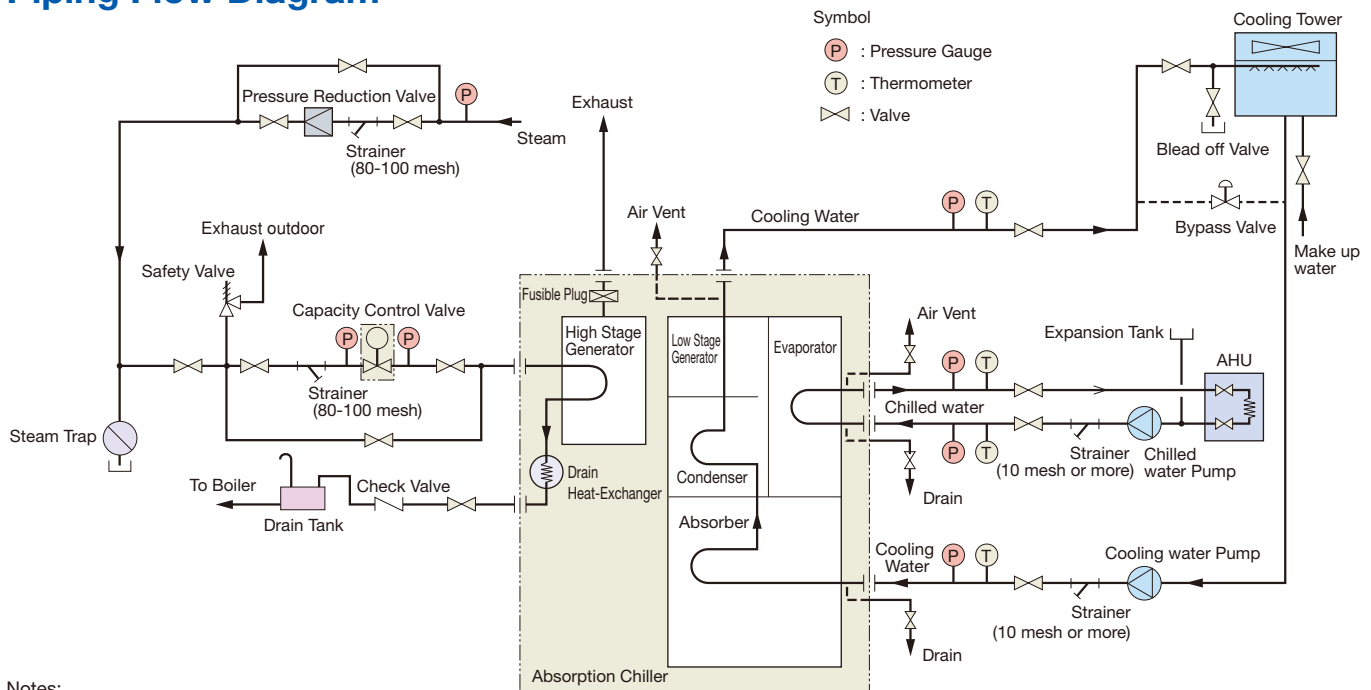

- Notes:
1. [Shaded area] indicate our scope of supply.
 2. Indicated parts in this drawing is our sample.
 3. Holding chilled water quantity must be more than 5 times of flow rate.

Maintenance Space & Insulation Area

Maintenance Space

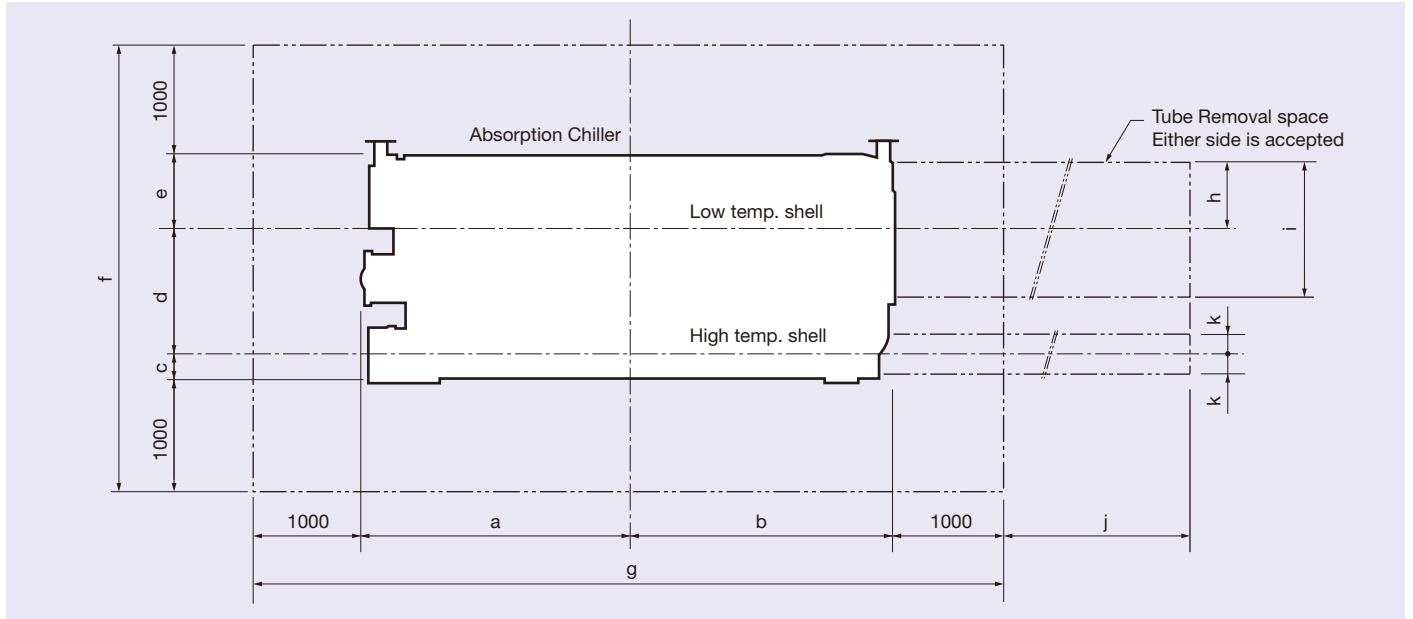

Model (REW)		015	018	021	025	028	032	036	040	045	050	056	063	070
a	mm	1805	1805	1805	1805	2345	2345	2345	2345	2420	2420	2670	2920	3170
b	mm	1775	1775	1780	1775	2315	2315	2320	2320	2390	2390	2640	2890	3140
c	mm	220	245	245	270	245	245	270	270	300	300	300	300	300
d	mm	790	835	870	929	902	910	997	1019	1070	1095	1290	1290	1290
e	mm	510	535	570	605	585	610	645	670	690	715	820	820	820
f	mm	3520	3615	3685	3804	3732	3765	3912	3959	4060	4110	4610	4610	4610
g	mm	5620	5620	5620	5620	6665	6665	6665	6665	6810	6810	7360	7860	8360
h	mm	400	425	460	495	475	500	540	560	585	610	765	765	765
i	mm	820	865	935	1005	970	1015	1095	1135	1185	1235	1545	1545	1545
j	mm	1735	1735	1730	1730	2680	2680	2680	2680	2580	2580	3150	3650	4190
k	mm	180	205	205	230	205	205	230	230	255	255	255	255	255

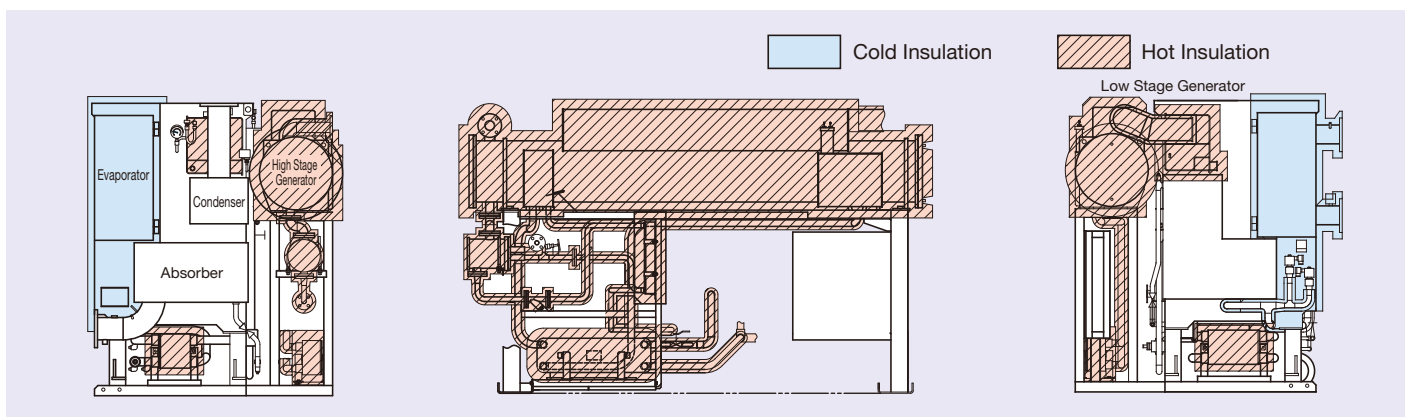

Cold Insulation Part

- Evaporator Shell
- Chilled water boxes & cover
- Refrigerant piping

High temperature Shell side

- High temperature Generator shell
- Solution Piping
- Solution heat exchangers

Low temperature shell side

- Steam header
- Refrigerant steam piping

Model (REW)		015	018	021	025	028	032	036	040	045	050	056	063	070
Cold Surface	m ²	8.0	8.5	9.0	10.0	11.5	12.5	13.1	15.0	16.0	17.0	22.8	24.0	25.9
Hot Surface	m ²	13.5	14.6	15.0	16.6	18.4	19.2	21.2	21.6	23.0	24.1	30.1	31.7	34.2



EBARA REFRIGERATION EQUIPMENT & SYSTEMS CO., LTD.

<http://www.ers.ebara.com/en/>

Head Office & Sales Department

3-2-16 Ohmorikita, Ohta-ku, Tokyo143-0016, JAPAN

EBARA CORPORATION

Head Office:

11-1, Haneda Asahi cho, Ohta-ku, Tokyo, 144-8510 Japan

Phone: +81-3-3743-6111 Fax: +81-3-3745-3356

All specifications are subject to change without notice.
"Model ○○○" in this catalog is our model code.

EXPORT CONTROL

Purchaser acknowledges and understands that Supplier maintains its own export control and complies with all applicable export control laws and regulations including Japan's Foreign Exchange and Foreign Trade Control Law and U.S. export control laws and regulations with respect to the Products and Purchaser shall fully cooperate with implementation of such Supplier's export control.