

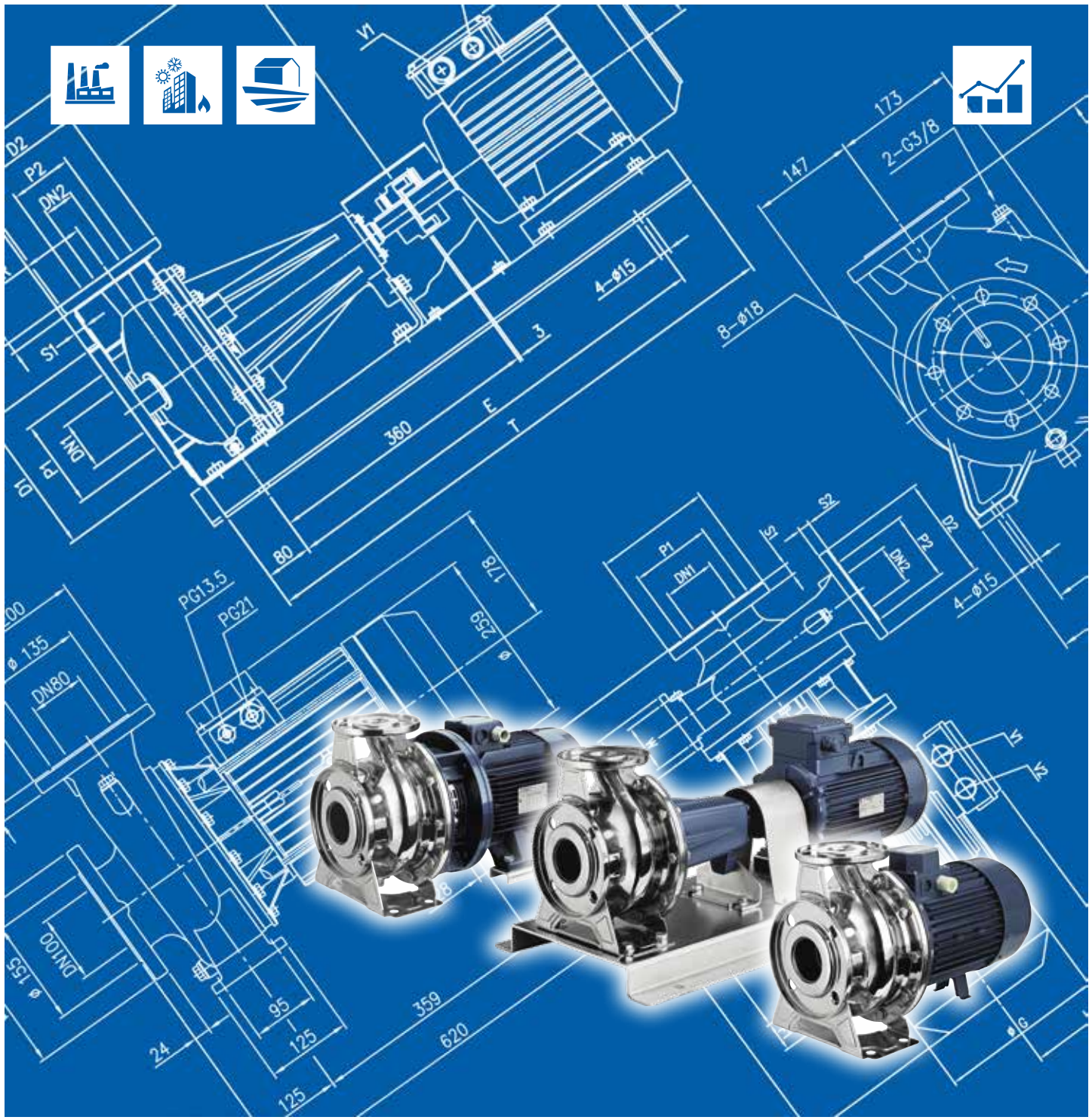

Japanese Technology since 1912

## 3 SERIES 4P

Data Book 50Hz



	Page
<b>- SPECIFICATION</b>	<b>200</b>
SPECIFICATION	201
SELECTION CHART	203-204
TYPE KEY AND CURVE SPECIFICATIONS	205-208
PERFORMANCE CURVE 32-125	209
PERFORMANCE CURVE 32-160	210
PERFORMANCE CURVE 32-200	211
PERFORMANCE CURVE 40-125	212
PERFORMANCE CURVE 40-160	213
PERFORMANCE CURVE 40-200	214
PERFORMANCE CURVE 50-125	215
PERFORMANCE CURVE 50-160	216
PERFORMANCE CURVE 50-200	217
PERFORMANCE CURVE 65-125	218
PERFORMANCE CURVE 65-160	219
PERFORMANCE CURVE 65-200	220
PERFORMANCE CURVE 65-250	221
PERFORMANCE CURVE 80-160	222
PERFORMANCE CURVE 80-200	223
PERFORMANCE CURVE 80-250	224
<b>- CONSTRUCTION</b>	<b>300</b>
SECTIONAL VIEW DRAWING 3(.)M4 32, 40, 50, 65-125/160/200	300
SECTIONAL VIEW TABLE 3(.)M4 32, 40, 50, 65-125/160/200	301
SECTIONAL VIEW DRAWING 3LM4 80-160	302
SECTIONAL VIEW TABLE 3LM4 80-160	303
SECTIONAL VIEW DRAWING 3LM4 65-250, 80-200/250	304
SECTIONAL VIEW TABLE 3LM4 65-250, 80-200/250	305
SECTIONAL VIEW DRAWING 3(.)S4 32, 40, 50, 65-125/160/200	306
SECTIONAL VIEW TABLE 3(.)S4 32, 40, 50, 65-125/160/200	307
SECTIONAL VIEW DRAWING 3LS4 80-160	308
SECTIONAL VIEW TABLE 3LS4 80-160	309
SECTIONAL VIEW DRAWING 3LS4 65-250, 80-200/250	310
SECTIONAL VIEW TABLE 3LS4 65-250, 80-200/250	311
SECTIONAL VIEW DRAWING 3(.)P4 32, 40, 50, 65-125/160/200	312
SECTIONAL VIEW TABLE 3(.)P4 32, 40, 50, 65-125/160/200	313
SECTIONAL VIEW DRAWING 3LP4 80-160	314
SECTIONAL VIEW DRAWING 3LP4 65-250, 80-200/250	315-316
SECTIONAL VIEW TABLE 3LP4 80-160	317
SECTIONAL VIEW TABLE 3LP4 65-250, 80-200/250	318

BEARINGS 3(.)M4-3(.)S4	319
BEARINGS 3(.)P4	320
MECHANICAL SEAL (standard, H and E version)	321
MECHANICAL SEAL (L version Ø 22)	322
MECHANICAL SEAL (L version Ø 30)	323
MECHANICAL SEAL (HS version)	324
MECHANICAL SEAL (HW and HSW version)	325
FLUID TEMPERATURE RANGE	326
COUPLING 3(.)S4	327
FLEXIBLE COUPLING 3(.)P4	328
FITTINGS	329-330
<b>- DIMENSIONS AND WEIGHT</b>	<b>400</b>
PUMP 3(.)M4 32, 40, 50, 65-125/160/200	400
PUMP 3(.)M4 65-250, 80-160/200, 80-250/5.5	401
PUMP 3(.)M4 80-250/7.5	402
PUMP 3(.)S4 32, 40, 50, 65-125/160	403
PUMP 3(.)S4 50, 65-160/200	404
PUMP 3LS4 65-250, 80	405
PUMP 3LS4 80-160/1.5	406
PUMP 3(.)P4 32, 40, 50, 65-125/160/200	407
PUMP 3LP4 65-250, 80	408
PACKING 3(.)M4	409
PACKING 3(.)S4	410
PACKING 3(.)P4	411
<b>- TECHNICAL DATA</b>	<b>500</b>
MOTOR DATA 3(.)M4	500
MOTOR DATA 3(.)S4-3(.)P4	501
NOISE DATA 3(.)M4	502
NOISE DATA 3(.)S4-3(.)P4	503

**SELECTION CHART**

50Hz

Rev. U

Version		3M4	3S4	3P4	3LM4	3LS4	3LP4
Pump sizes	32-125	■	■	■	●	●	●
	32-160	■	■	■	●	●	●
	32-200	■	■	■	●	●	●
	40-125	■	■	■	●	●	●
	40-160	■	■	■	●	●	●
	40-200	■	■	■	●	●	●
	50-125	■	■	■	●	●	●
	50-160	■	■	■	●	●	●
	50-200	■	■	■	●	●	●
	65-125	■	■	■	●	●	●
	65-160	■	■	■	●	●	●
	65-200	■	■	■	●	●	●
	65-250	-	-	-	●	●	●
	80-160	-	-	-	●	●	●
	80-200	-	-	-	●	●	●
80-250	-	-	-	●	●	●	

■ Available also with H, HS, HW, HSW, E version.

● Available also with H, HW, HSW, E version.

— Not available.

## SELECTION CHART

50Hz

Rev. U

PUMP								
Version		3M4	3S4	3P4	3LM4	3LS4	3LP4	
Liquid Handled	Type of liquid	Clean water and moderately aggressive fluids						
	Temperature [°C]	min. -10 max. +120 For full details see section "FLUID TEMPERATURE RANGE"						
Maximum working pressure [MPa]		1						
Construction	Impeller	Closed centrifugal type for 32, 40, 50 version Reinforced laser welding for 40-200/1.5, 50-200/2.2 Closed centrifugal three dimensional blades for 65 and 80 version						
	Shaft seal type	Mechanical seal			Mechanical seal with stationary ring secured against rotation			
	Bearing	Bearing with contact seal						
Pipe Connection	Suction	32-125/160/200	Flange DN50 according EN1092-1 Standard					
		40-125/160/200	Flange DN65 according EN1092-1 Standard					
		50-125/160/200	Flange DN80 according EN1092-1 Standard					
		65-125/160/200/250	Flange DN100 according EN1092-1 Standard					
	Discharge	32-125/160/200	Flange DN32 according EN1092-1 Standard					
		40-125/160/200	Flange DN40 according EN1092-1 Standard					
		50-125/160/200	Flange DN50 according EN1092-1 Standard					
		65-125/160/200/250	Flange DN65 according EN1092-1 Standard					
Material	Casing	32-125/160/200 40-125/160/200 50-125/160/200 65-125/160/200	EN 1.4301 (AISI 304)			EN 1.4404 (AISI 316L)		
		65-250 80-160/200/250	/			CF8M - EN 1.4408 (AISI 316)		
	Impeller	32-125/160/200 40-125/160/200 50-125/160/200	EN 1.4301 (AISI 304)			EN 1.4404 (AISI 316L)		
		65-125/160/200 65-250 80-160/200/250	/			CF8M - EN 1.4408 (AISI 316)		
	Casing cover	32-125/160/200 40-125/160/200 50-125/160/200 65-125/160/200	EN 1.4301 (AISI 304)			EN 1.4404 (AISI 316L)		
		65-250 80-160/200/250	/			CF8M - EN 1.4408 (AISI 316)		
	Mechanical seal	32-125/160/200 40-125/160/200 50-125/160/200 65-125/160/200	Ceramic/Carbon/NBR (See page 321+325)			SiC/SiC/FPM (L version) (See page 321+325)		
		65-250 80-160/200/250	/					
	O-ring	NBR (See page 321+325)			FPM (See page 321+325)			
	Shaft	32, 40, 50, 65	d=19	EN 1.4301 (AISI 304)			EN 1.4404 (AISI 316L)	
		50-200/2.2	d=22					
		80-160	d=19					
		65-250 80-200/250	d=24	/				
	Bracket	Cast iron - Aluminium						
	Applicable standard of test		ISO 9906:2012 – Grade 3B					

**SELECTION CHART**

50Hz

Rev. U

<b>MOTOR</b>			
	3(.)M4	3(.)S4	3(.)P4
Type	Electric - TEFC Three Phase		
Efficiency level (Reg. 1781/2019)	IE2 from 0.25 kW up to 0.55 kW IE3 from 0.75 kW up to 7.5 kW		
No. of Poles	4		
Rotation speed [min <sup>-1</sup> ]	≈ 1400		
Insulation Class	F (class B for temperature rise)		
Protection degree (CEI EN 60034-5)	IP 55		
Power rating [kW]	0.25 ÷ 7.5		
[HP]	0.33 ÷ 10		
Frequency [Hz]	50		
Voltage [V]	230/400 ±10% (up to 4.0 kW) 400/690 ±10% (5.5 kW and above)		
Over load protection	Provided by the user		
Casing material	Aluminium		
Motor support	Cast iron - Alluminium		
Dimensions of cable entry	PG11 PG13.5 PG16 PG21 * M25X1,5 * M20X1,5	M20x1.5 M25x1.5 M32x1.5	
Flange mount (IEC motor)	/	IM B5 (up to 1.5 kW) IM B35 (2.2 kw and above)	IM B3

\* Only for 65-250/4,80-200/4 models

## SELECTION CHART

50Hz

Rev. U

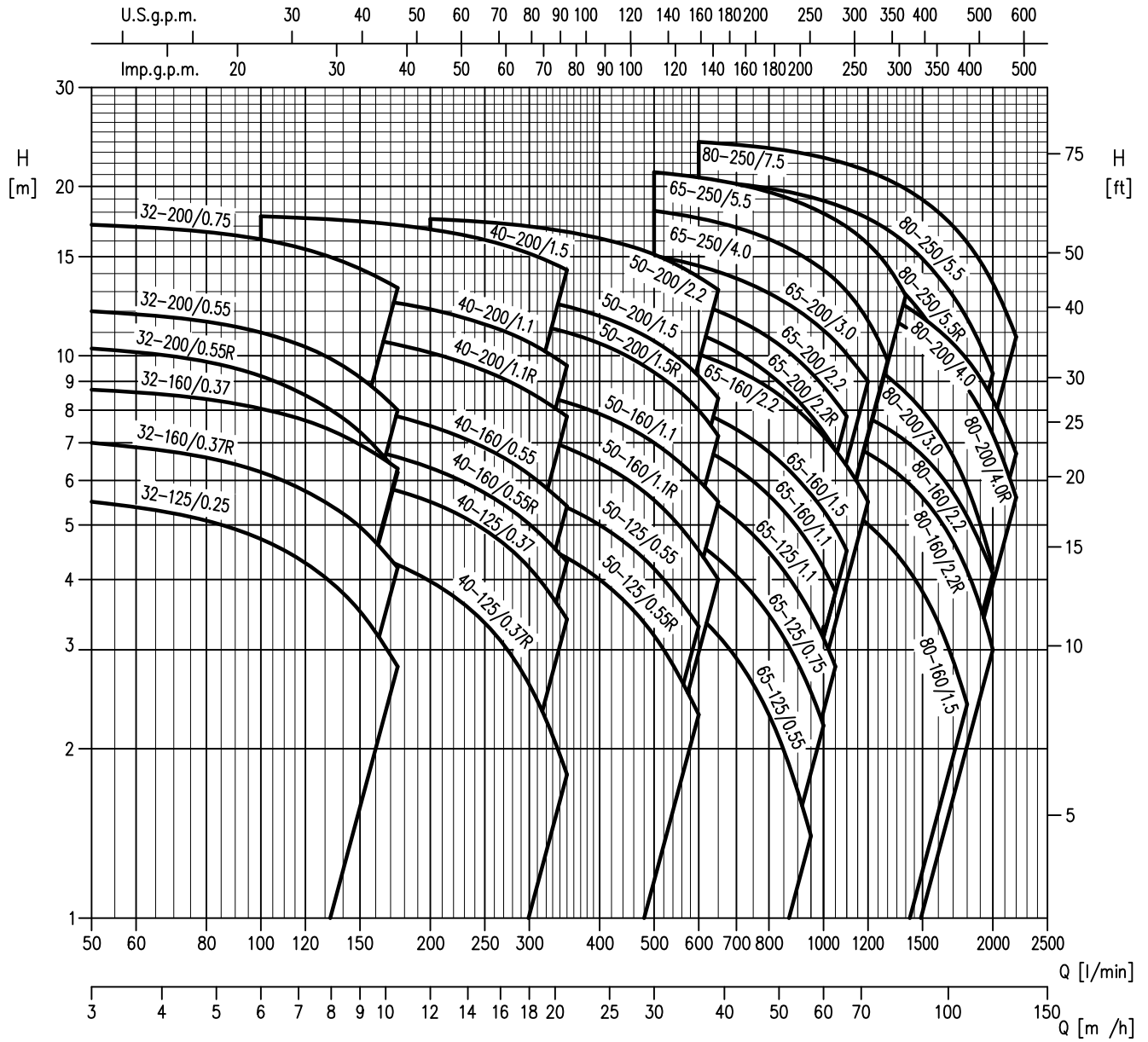

## SELECTION CHART

50Hz

Rev. U

### 3 SERIES 4 Poles: 32, 40, 50 Version

Pump type	Power		Q=Capacity													
	[kW]	[HP]	l/min	0	50	100	150	175	200	250	300	350	400	500	600	650
			m³/h	0	3	6	9	10.5	12	15	18	21	24	30	36	39
H=Total manometric head in meters																
32-125/0.25	0.25	0.33	5.7	5.5	4.7	3.5	2.8	-	-	-	-	-	-	-	-	-
32-160/0.37R	0.37	0.5	7.3	7	6.2	5	4.2	-	-	-	-	-	-	-	-	-
32-160/0.37	0.37	0.5	9	8.7	8.1	7	6.3	-	-	-	-	-	-	-	-	-
32-200/0.55R	0.55	0.75	10.8	10.3	9.2	7.3	6.2	-	-	-	-	-	-	-	-	-
32-200/0.55	0.55	0.75	12.5	12	11	9.2	8	-	-	-	-	-	-	-	-	-
32-200/0.75	0.75	1	17.5	17.1	16.1	14.3	13.2	-	-	-	-	-	-	-	-	-
40-125/0.37R	0.37	0.5	5.1	-	4.8	4.5	4.3	4	3.4	2.6	1.8	-	-	-	-	-
40-125/0.37	0.37	0.5	6.5	-	6.3	6	5.8	5.5	4.9	4.2	3.4	-	-	-	-	-
40-160/0.55R	0.55	0.75	7.7	-	7.3	6.9	6.6	6.3	5.7	5	4.3	-	-	-	-	-
40-160/0.55	0.55	0.75	9.1	-	8.6	8.1	7.8	7.5	6.9	6.2	5.4	-	-	-	-	-
40-200/1.1R	1.1	1.5	11.6	-	11.2	10.8	10.5	10.1	9.4	8.6	7.8	-	-	-	-	-
40-200/1.1	1.1	1.5	13.6	-	13.2	12.7	12.4	12.1	11.4	10.6	9.6	-	-	-	-	-
40-200/1.5	1.5	2	18	-	17.7	17.3	17.1	16.8	16.1	15.2	14.2	-	-	-	-	-
50-125/0.55R	0.55	0.75	5.4	-	-	-	-	5.2	5	4.7	4.4	4	3.2	2.3	-	-
50-125/0.55	0.55	0.75	6.4	-	-	-	-	6.2	6	5.7	5.4	5	4.2	3.3	-	-
50-160/1.1R	1.1	1.5	8.2	-	-	-	-	7.8	7.6	7.2	6.9	6.4	5.5	4.5	4	-
50-160/1.1	1.1	1.5	9.5	-	-	-	-	9.1	8.9	8.6	8.3	7.9	7	6	5.5	-
50-200/1.5R	1.5	2	12.7	-	-	-	-	12.1	11.8	11.4	11	10.5	9.3	8	7.2	-
50-200/1.5	1.5	2	14	-	-	-	-	13.3	13	12.7	12.2	11.8	10.6	9.2	8.4	-
50-200/2.2	2.2	3	17.8	-	-	-	-	17.5	17.3	17	16.6	16.2	15.1	13.8	13.1	-

### 3 SERIES 4 Poles: 65, 80 Version

Pump type	Power		Q=Capacity																	
	[kW]	[HP]	l/min	0	300	350	500	600	800	950	1000	1050	1100	1200	1300	1400	1600	1800	2000	2200
			m³/h	0	18	21	30	36	48	57	60	63	66	72	78	84	96	108	120	132
H=Total manometric head in meters																				
65-125/0.55	0.55	0.75	5.3	4.8	4.6	4	3.5	2.3	1.4	-	-	-	-	-	-	-	-	-	-	-
65-125/0.75	0.75	1	6.4	6	5.8	5.2	4.6	3.5	2.5	2.2	-	-	-	-	-	-	-	-	-	-
65-125/1.1	1.1	1.5	7.7	7.2	7	6.3	5.7	4.5	3.5	3.2	2.8	-	-	-	-	-	-	-	-	-
65-160/1.1	1.1	1.5	8.6	-	8.1	7.4	6.9	5.7	4.6	4.2	3.8	-	-	-	-	-	-	-	-	-
65-160/1.5	1.5	2	9.7	-	9.2	8.5	8	6.7	5.7	5.3	4.9	4.5	-	-	-	-	-	-	-	-
65-160/2.2	2.2	3	11.8	-	11.3	10.6	10.1	8.8	7.6	7.2	6.8	6.4	5.5	-	-	-	-	-	-	-
65-200/2.2R	2.2	3	13	-	12.4	11.6	10.9	9.3	7.8	7.3	6.8	-	-	-	-	-	-	-	-	-
65-200/2.2	2.2	3	14.5	-	13.9	13	12.4	10.8	9.3	8.8	8.3	7.8	-	-	-	-	-	-	-	-
65-200/3	3	4	16.3	-	15.8	15.1	14.4	12.9	11.6	11.1	10.6	10.1	9	-	-	-	-	-	-	-
65-250/4	4	5.5	18.8	-	-	18.1	17.6	16.1	14.7	14.2	13.7	13	11.6	9.8	-	-	-	-	-	-
65-250/5.5	5.5	7.5	21.8	-	-	21.2	20.8	19.6	18.4	17.9	17.5	17	15.8	14.4	12.8	-	-	-	-	-
80-160/1.5	1.5	2	7.3	-	-	-	6.8	6.3	5.9	5.7	5.6	5.4	5	4.6	4.2	3.4	2.4	-	-	-
80-160/2.2R	2.2	3	8.6	-	-	-	8.1	7.8	7.4	7.3	7.1	7	6.7	6.4	6	5.2	4.2	3	-	-
80-160/2.2	2.2	3	9.5	-	-	-	9.1	8.8	8.4	8.3	8.2	8	7.8	7.4	7.1	6.2	5.2	4.1	-	-
80-200/3	3	4	12.4	-	-	-	12	11.5	10.9	10.7	10.4	10.2	9.7	9.2	8.6	7.3	5.9	4.2	-	-
80-200/4R	4	5.5	14.8	-	-	-	14.4	13.9	13.4	13.2	12.9	12.7	12.2	11.7	11.2	10.1	8.8	7.2	5.6	-
80-200/4	4	5.5	16.0	-	-	-	15.4	14.9	14.3	14.1	13.9	13.7	13.2	12.8	12.3	11.1	9.9	8.4	6.7	-
80-250/5.5R	5.5	7.5	18.5	-	-	-	17.7	17	16.3	16	15.7	15.4	14.6	13.8	12.9	10.7	8.4	-	-	-
80-250/5.5	5.5	7.5	21.2	-	-	-	20.5	19.9	19.1	18.9	18.6	18.2	17.6	16.8	15.9	13.8	11.7	9.3	-	-
80-250/7.5	7.5	10	24.5	-	-	-	24	23.4	22.8	22.5	22.2	21.9	21.3	20.6	19.8	18	15.9	13.5	10.8	-



## TYPE KEY AND CURVE SPECIFICATIONS

50Hz

Rev. U

### TYPE KEY:

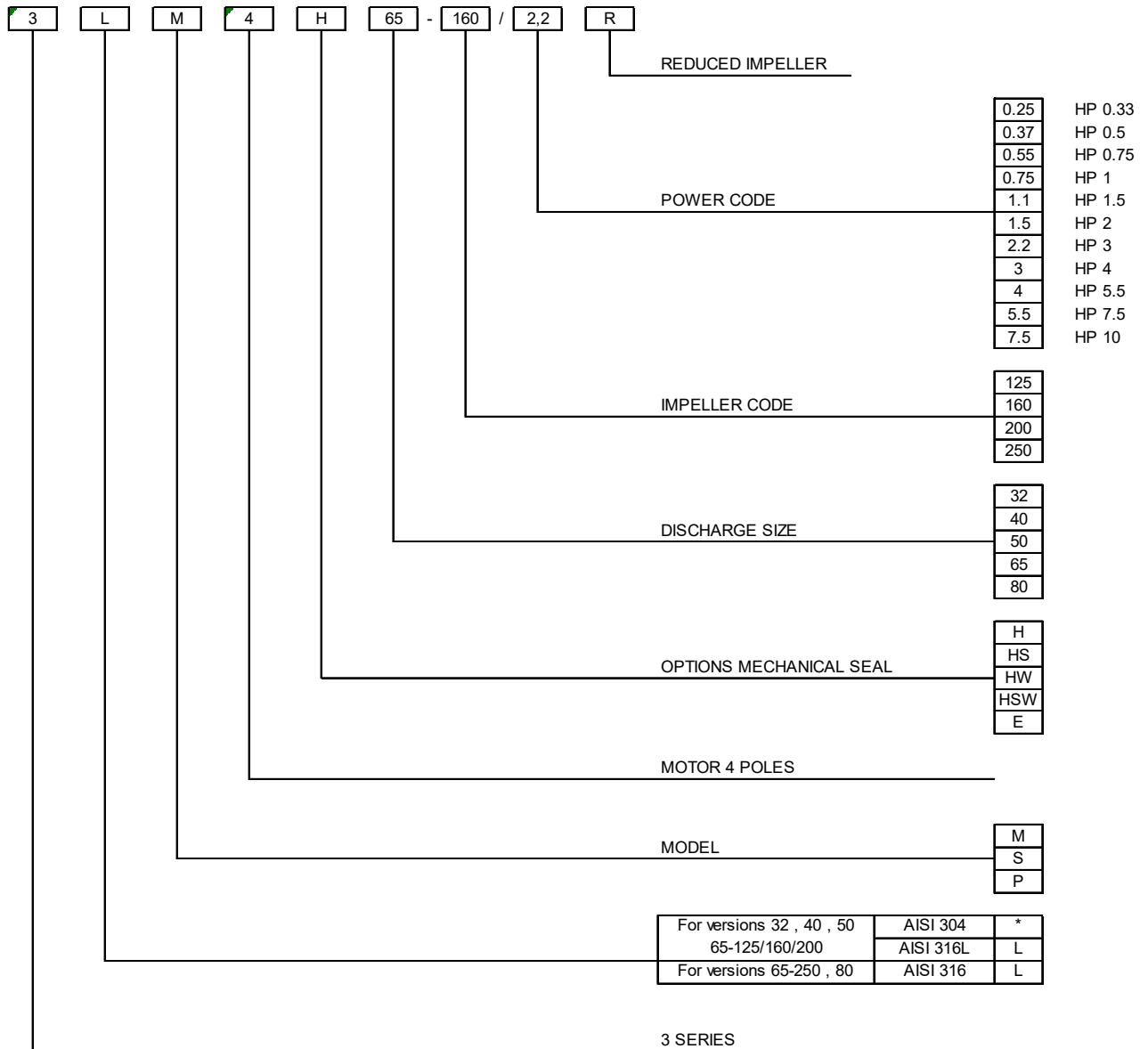

(\*) No indication

**PERFORMANCE CURVE SPECIFICATIONS**

The specifications below qualify the curves shown on the following pages.

Tolerances according to ISO 9906:2012 - Grade 3B

The curves refer to effective speed of asynchronous motors at 50 Hz, 4 poles.

Measurements were carried out with clean water at 20°C of temperature and with a kinematic viscosity of  $\nu = 1 \text{ mm}^2/\text{s}$  (1 cSt)

The NPSH curve is an average curve obtained in the same conditions of performance curves.

The continuous curves indicate the recommended working range. The dotted curve is only a guide.

In order to avoid the risk of over-heating, the pumps should not be used at a flow rate below 10% of best efficiency point.

Symbols explanation:

Q = volume flow rate

H = total head

$P_2$  = pump power input (shaft power)

$\eta$  = pump efficiency

NPSH = net positive suction head required by the pump

MEI = minimum efficiency index

The minimum efficiency index (MEI) is a measure of the quality of a pump size in respect to its mean efficiency. The minimum efficiency index is based on the hydraulic efficiency and on the head at the best efficiency point.

The efficiency of a pump with trimmed impeller is usually lower than that of a pump with the full impeller diameter. The trimming of the impeller will adapt the pump to a fixed duty point, leading to a reduced energy consumption. The minimum efficiency index (MEI) is based on the full impeller diameter.

The operation of these water pumps with variable duty points may be more efficient and economical when controlled, for example, by the use of a variable speed drive that matches the pump duty to the system

MEI=0.4 for ESCC 1450rpm

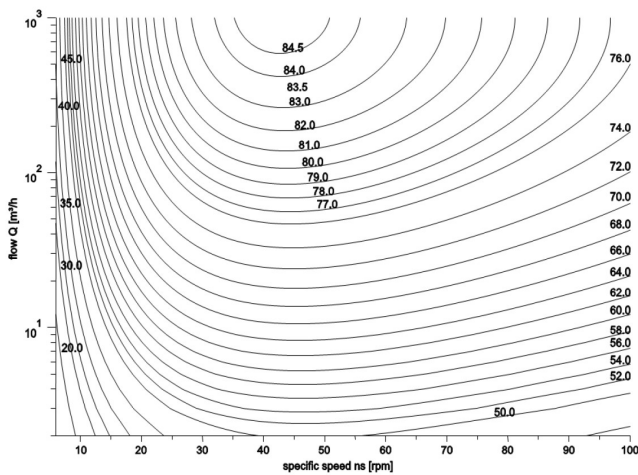

MEI = 0.7 for ESCC 1450rpm

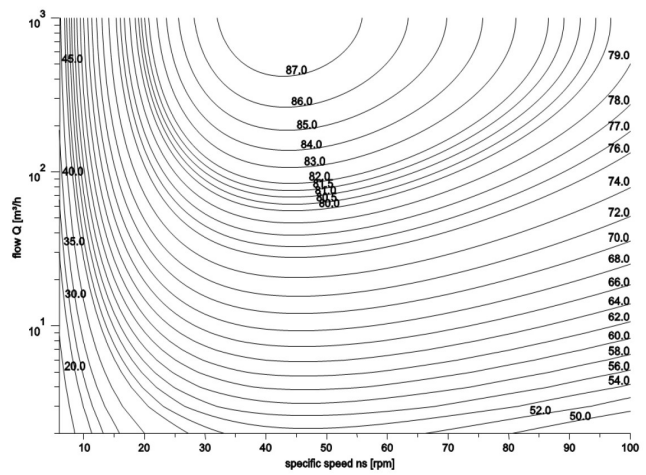

MEI = 0.4 for ESOB 1450

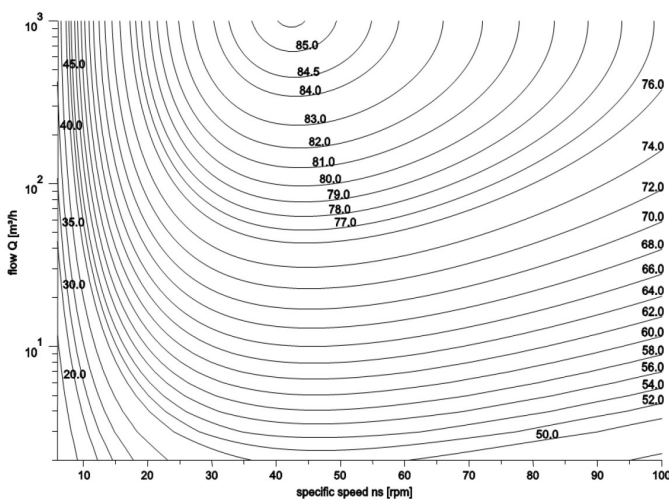

MEI = 0.7 for ESOB 1450 rpm

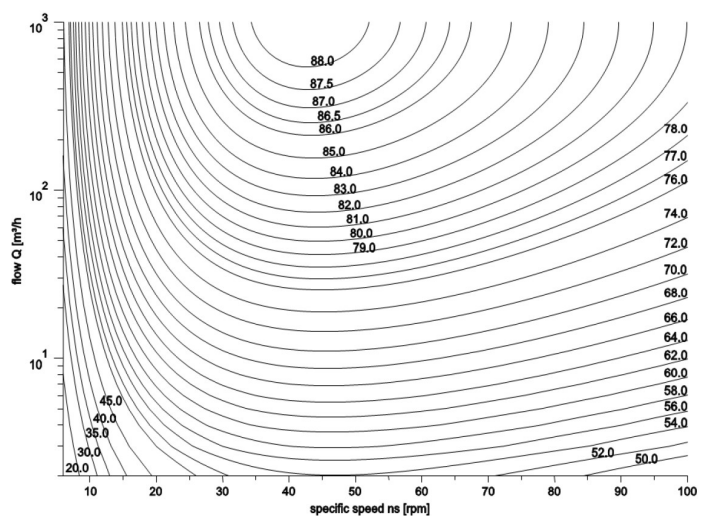

**MEI INDEX VALUE**

SIZE	MEI VALUE		
	3M4	3S4	3P4
32-125	≥ 0.7	≥ 0.7	≥ 0.7
32-160	≥ 0.6	≥ 0.6	≥ 0.5
32-200	≥ 0.7	≥ 0.7	≥ 0.7
40-125	≥ 0.6	≥ 0.6	≥ 0.5
40-160	≥ 0.7	≥ 0.7	≥ 0.7
40-200	≥ 0.7	≥ 0.7	≥ 0.7
50-125	≥ 0.7	≥ 0.7	≥ 0.6
50-160	≥ 0.6	≥ 0.6	≥ 0.5
50-200	≥ 0.7	≥ 0.7	≥ 0.7
65-125	≥ 0.5	≥ 0.5	≥ 0.5
65-160	≥ 0.5	≥ 0.5	≥ 0.4
65-200	≥ 0.7	≥ 0.7	≥ 0.6
65-250	≥ 0.7	≥ 0.7	≥ 0.7
80-160	≥ 0.6	≥ 0.6	≥ 0.5
80-200	≥ 0.5	≥ 0.5	≥ 0.4
80-250	≥ 0.6	≥ 0.6	≥ 0.5

32-125/0.25 (0.25 kW) – impeller diameter = 133 mm

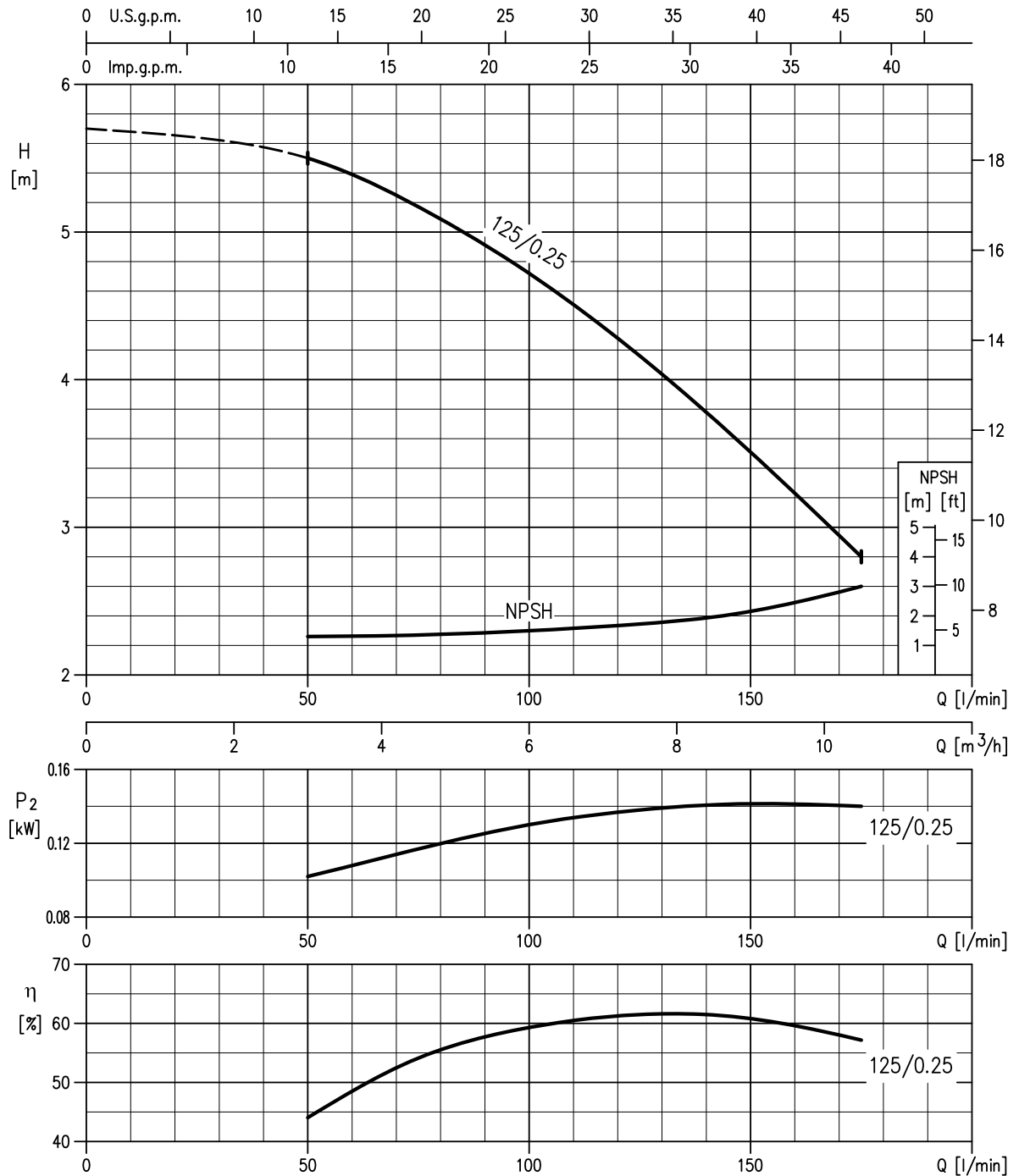

Rotation speed ≈ 1400 min<sup>-1</sup>  
 Test standard: ISO 9906:2012 – Grade 3B

**32-160/0.37R (0.37kW) – impeller diameter = 151 mm**  
**32-160/0.37 (0.37kW) – impeller diameter = 166 mm**

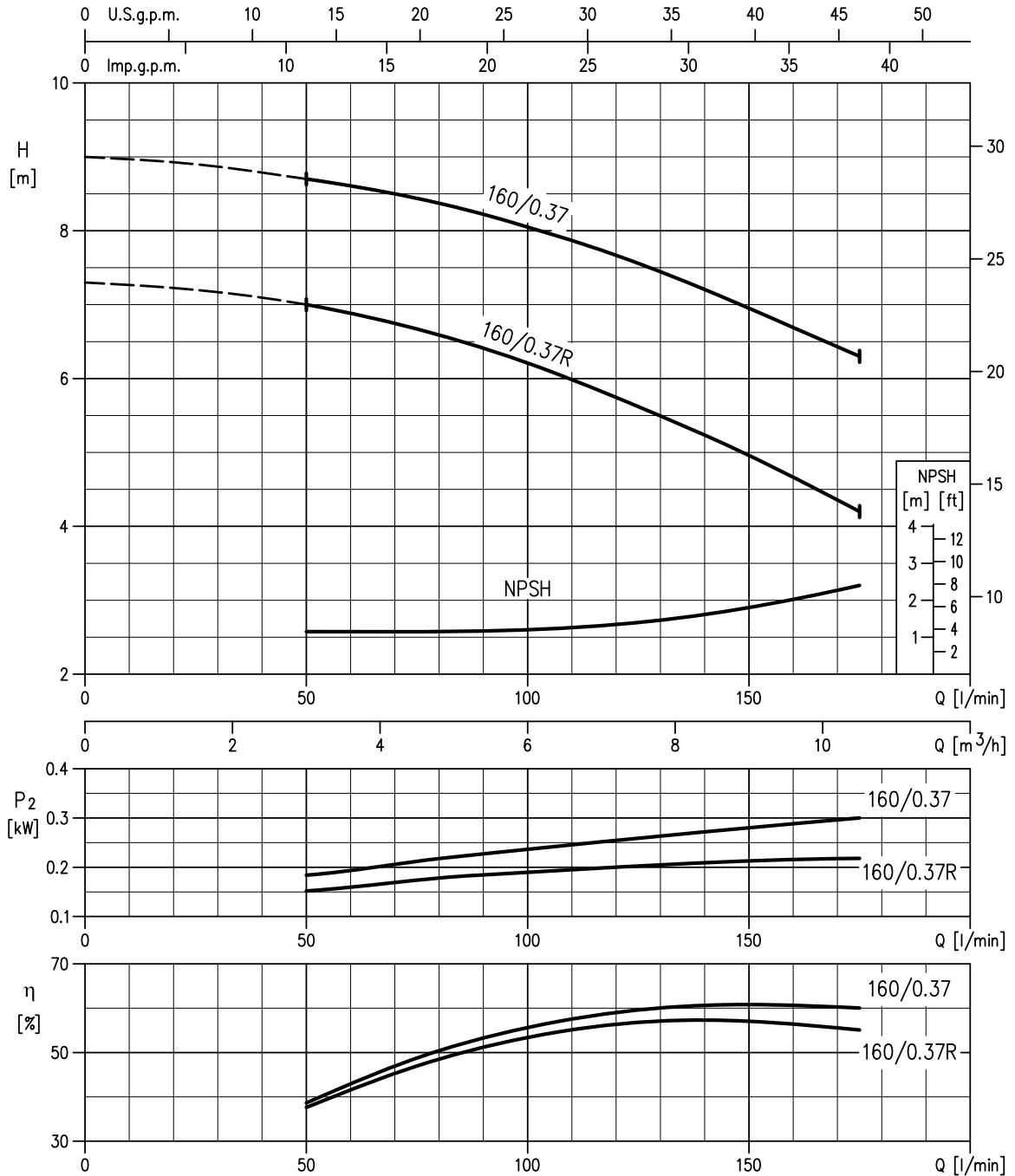

Rotation speed ≈ 1400 min<sup>-1</sup>  
 Test standard: ISO 9906:2012 – Grade 3B

32-200/0.55R (0.55 kW) – impeller diameter = 186 mm  
 32-200/0.55 (0.55kW – impeller diameter = 200 mm  
 32-200/0.75 (0.55kW) – impeller diameter = 224 mm

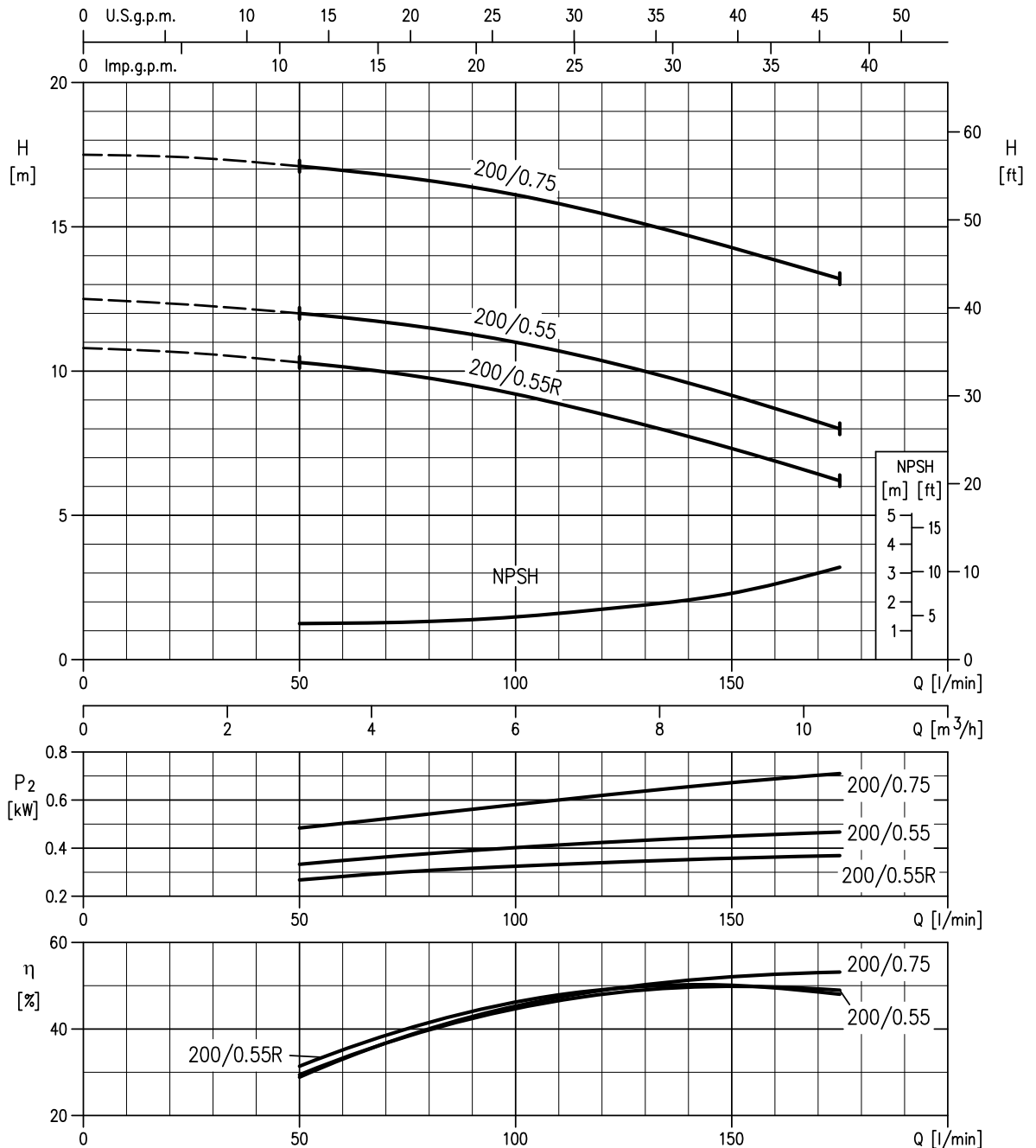

Rotation speed ≈ 1400 min<sup>-1</sup>  
 Test standard: ISO 9906:2012 – Grade 3B

40-125/0.37R (0.37 kW) – impeller diameter = 125 mm  
 40-125/0.37 (0.37 kW) – impeller diameter = 140 mm

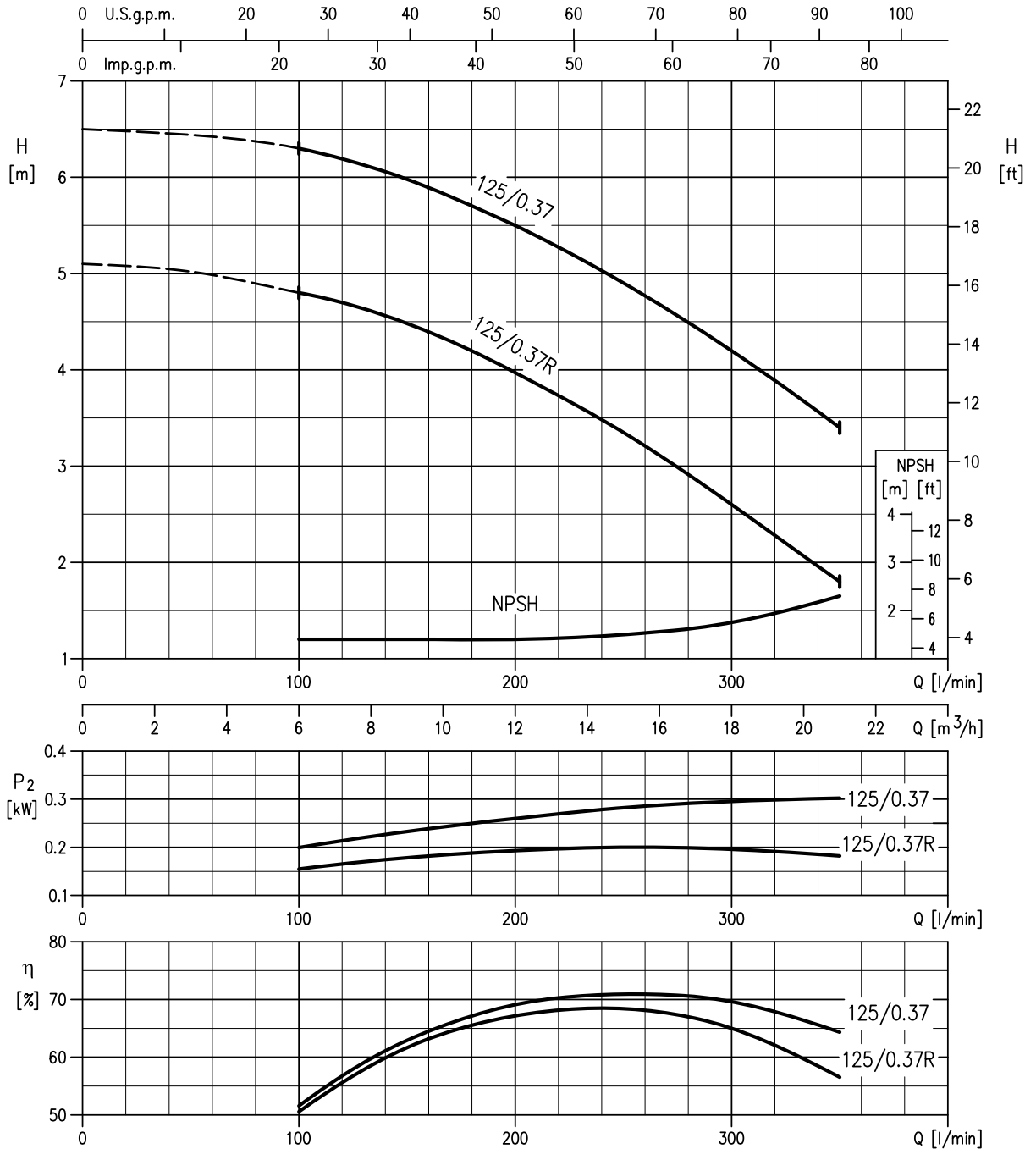

Rotation speed ≈ 1400 min<sup>-1</sup>  
 Test standard: ISO 9906:2012 – Grade 3B



**40-160/0.55R (0.55 kW) – impeller diameter = 151 mm**  
**40-160/0.55 (0.55 kW) – impeller diameter = 166 mm**

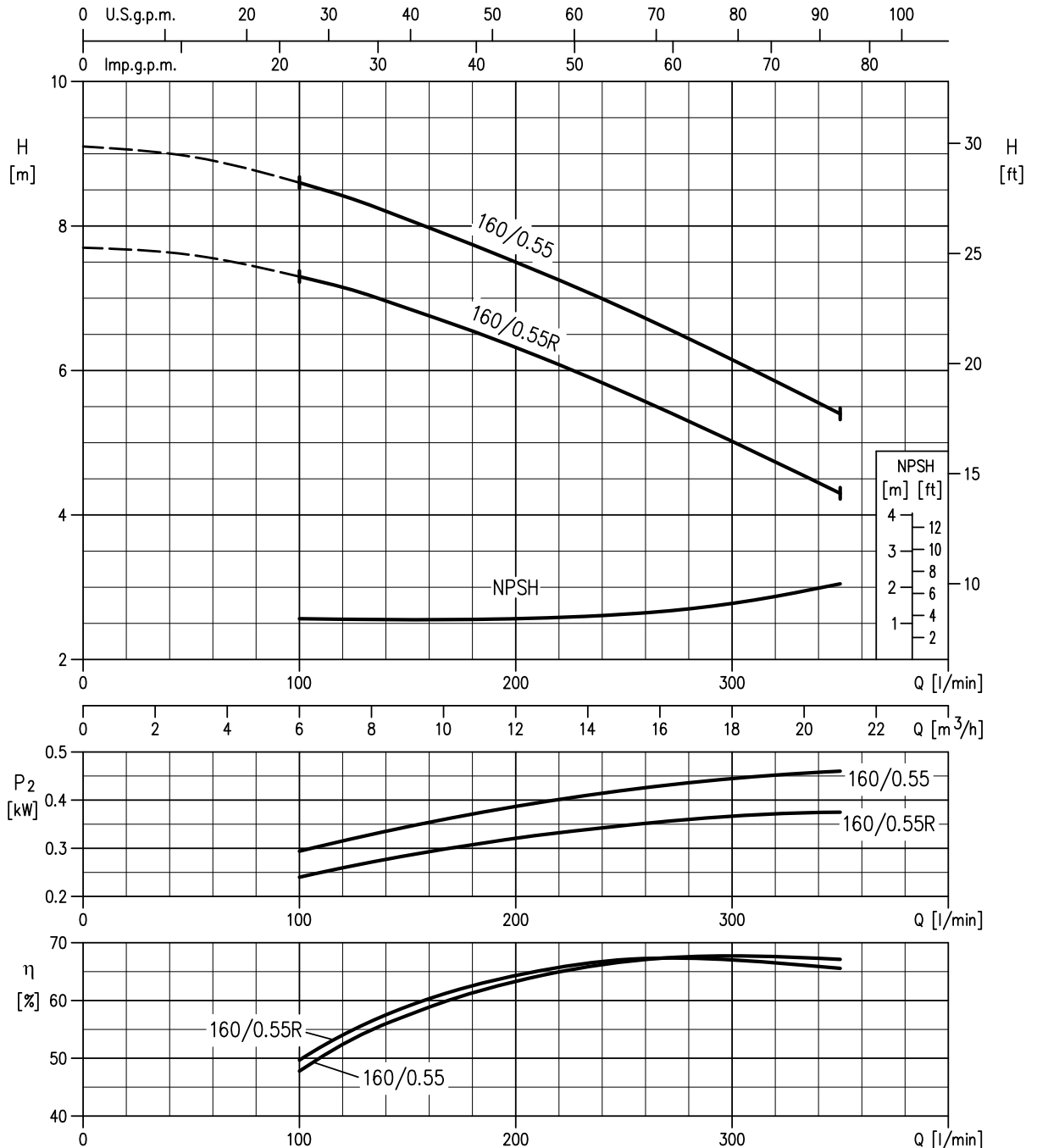

Rotation speed ≈ 1400 min<sup>-1</sup>  
 Test standard: ISO 9906:2012 – Grade 3B

40-200/1.1R (1.1 kW) – impeller diameter = 183 mm  
 40-200/1.1 (1.1 kW) – impeller diameter = 200 mm  
 40-200/1.5 (1.5 kW) – impeller diameter = 224 mm

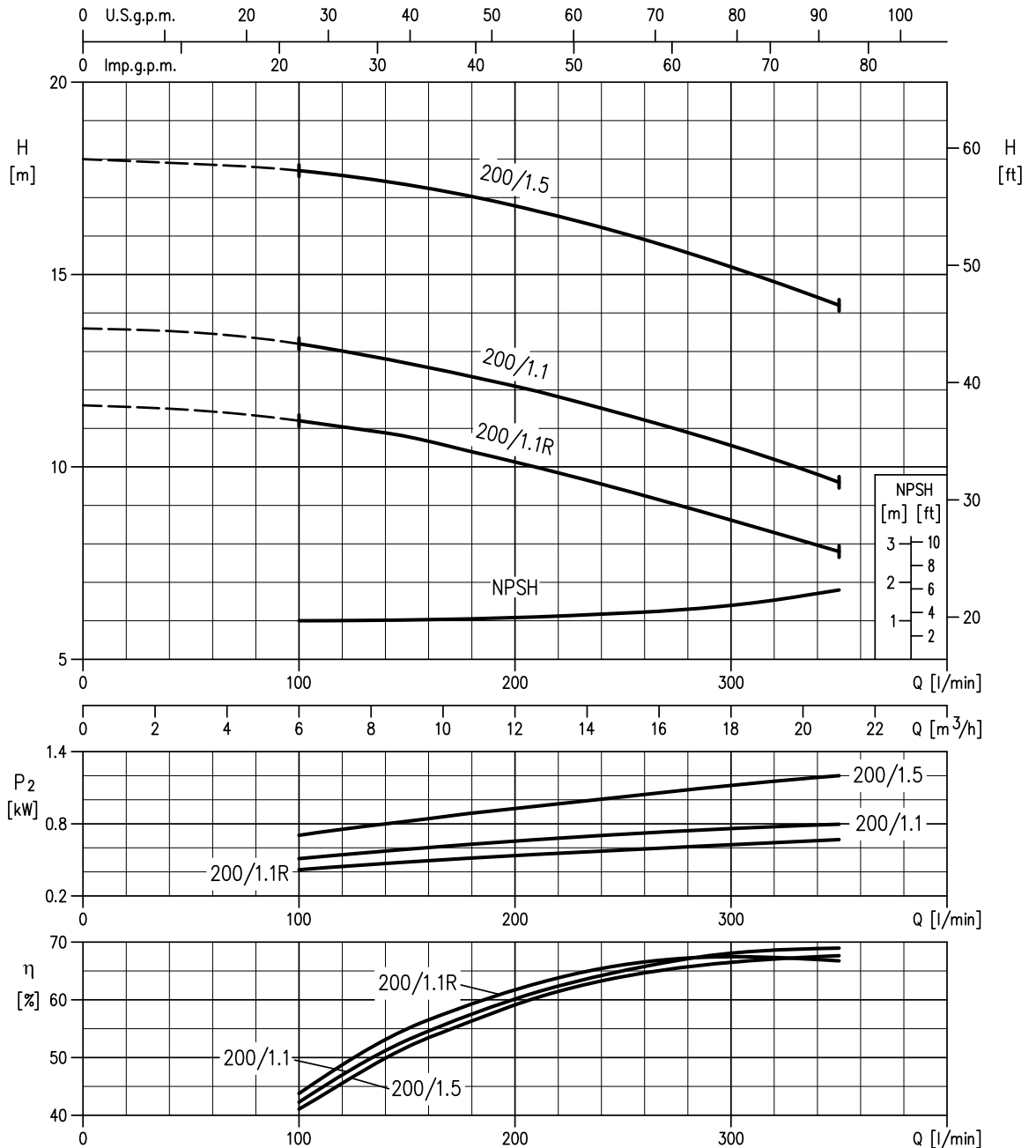

Rotation speed  $\approx 1400 \text{ min}^{-1}$   
 Test standard: ISO 9906:2012 – Grade 3B

50-125/0.55R (0.55 kW) – impeller diameter = 131 mm  
 50-125/0.55 (0.55 kW) – impeller diameter = 140 mm

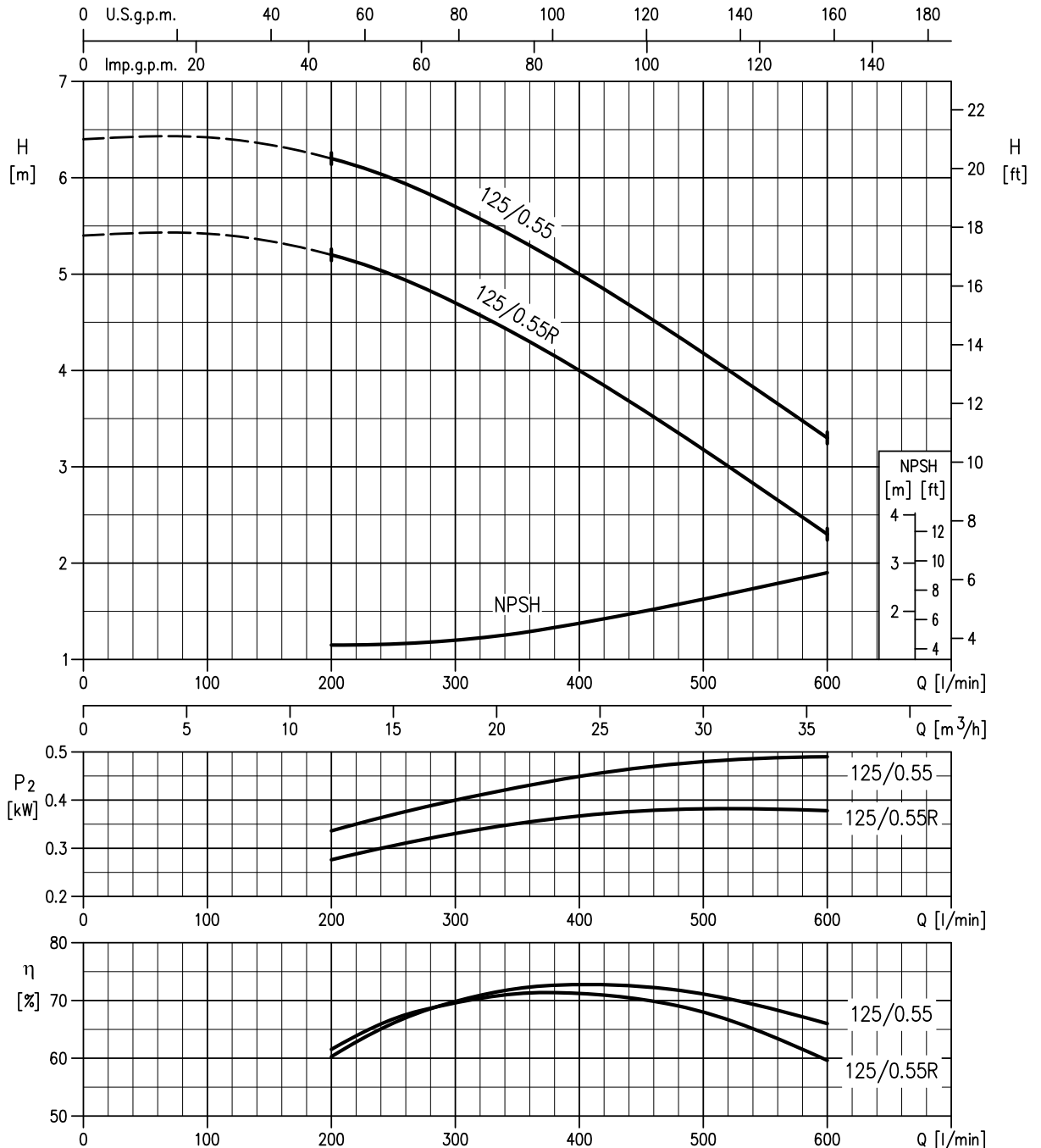

Rotation speed ≈ 1400 min<sup>-1</sup>  
 Test standard: ISO 9906:2012 – Grade 3B

**50-160/1.1R (1.1 kW) – impeller diameter = 154 mm**  
**50-160/1.1 (1.1 kW) – impeller diameter = 166 mm**

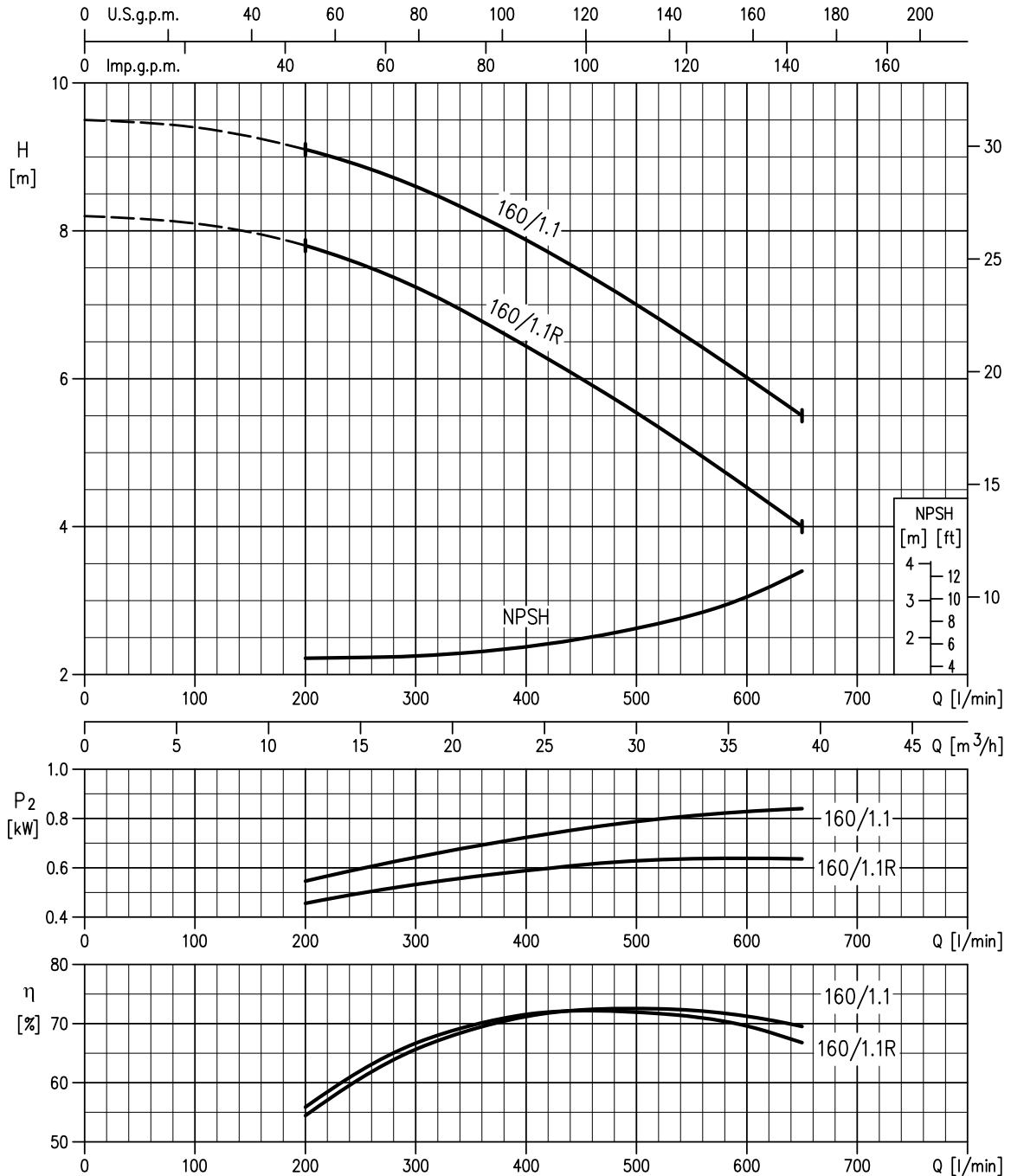

Rotation speed ≈ 1400 min<sup>-1</sup>  
 Test standard: ISO 9906:2012 – Grade 3B

50-200/1.5R (1.5 kW) – impeller diameter = 191 mm  
 50-200/1.5 (1.5 kW) – impeller diameter = 200 mm  
 50-200/2.2 (2.2 kW) – impeller diameter = 224 mm

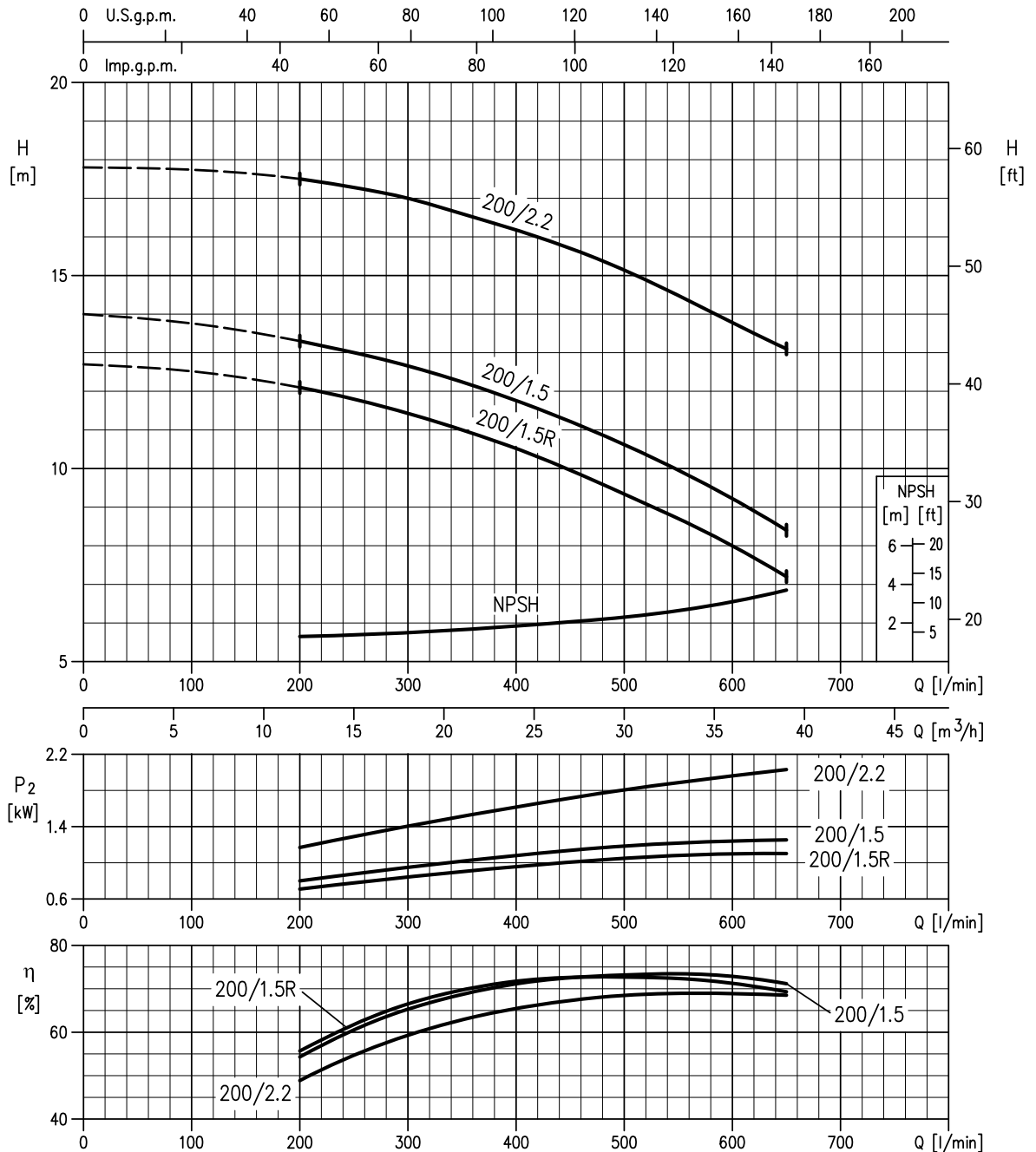

Rotation speed ≈ 1400 min<sup>-1</sup>  
 Test standard: ISO 9906:2012 – Grade 3B

65-125/0.55 (0.55 kW) – impeller diameter = 128 mm  
 65-125/0.75 (0.75 kW) – impeller diameter = 138 mm  
 65-125/1.1 (1.1 kW) – impeller diameter = 149 mm

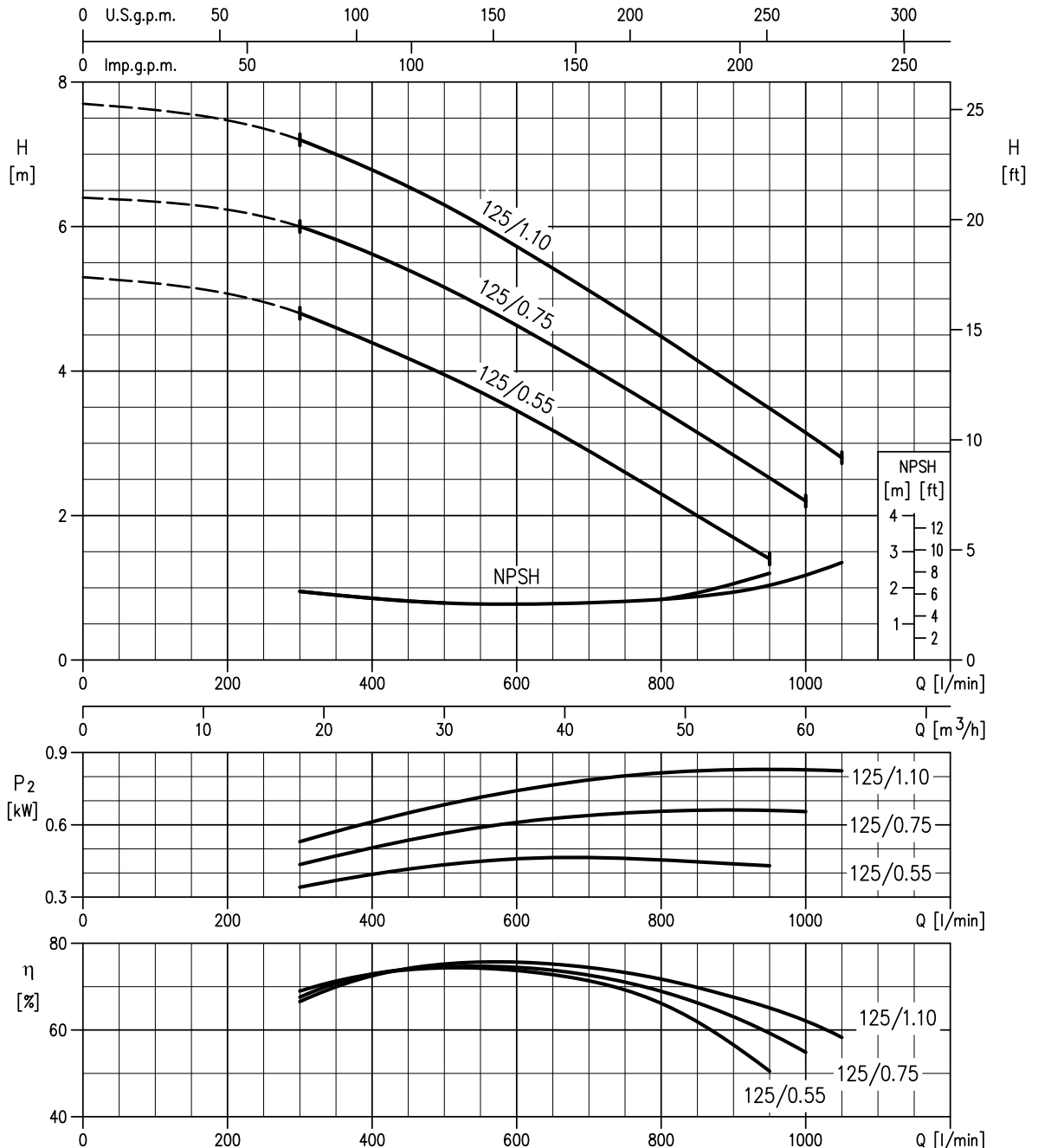

Rotation speed ≈ 1400 min<sup>-1</sup>  
 Test standard: ISO 9906:2012 – Grade 3B

65-160/1.1 (1.1 kW) – impeller diameter = 161 mm  
 65-160/1.5 (1.5 kW) – impeller diameter = 168 mm  
 65-160/2.2 (2.2 kW) – impeller diameter = 178 mm

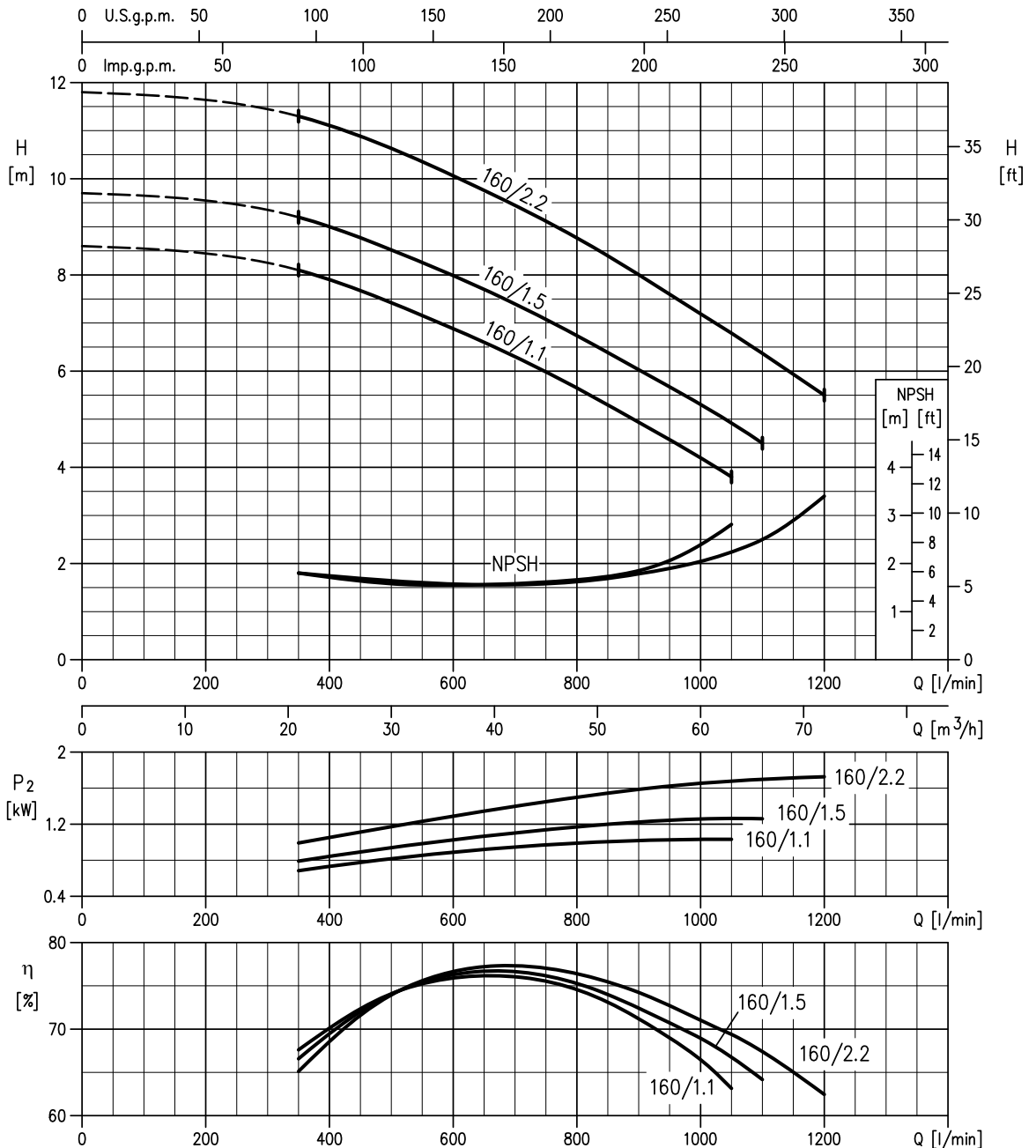

Rotation speed  $\approx 1400 \text{ min}^{-1}$   
 Test standard: ISO 9906:2012 – Grade 3B

65-200/2.2R (2.2 kW) – impeller diameter = 190 mm  
 65-200/2.2 (2.2 kW) – impeller diameter = 201 mm  
 65-200/3 (3.0 kW) – impeller diameter = 212 mm

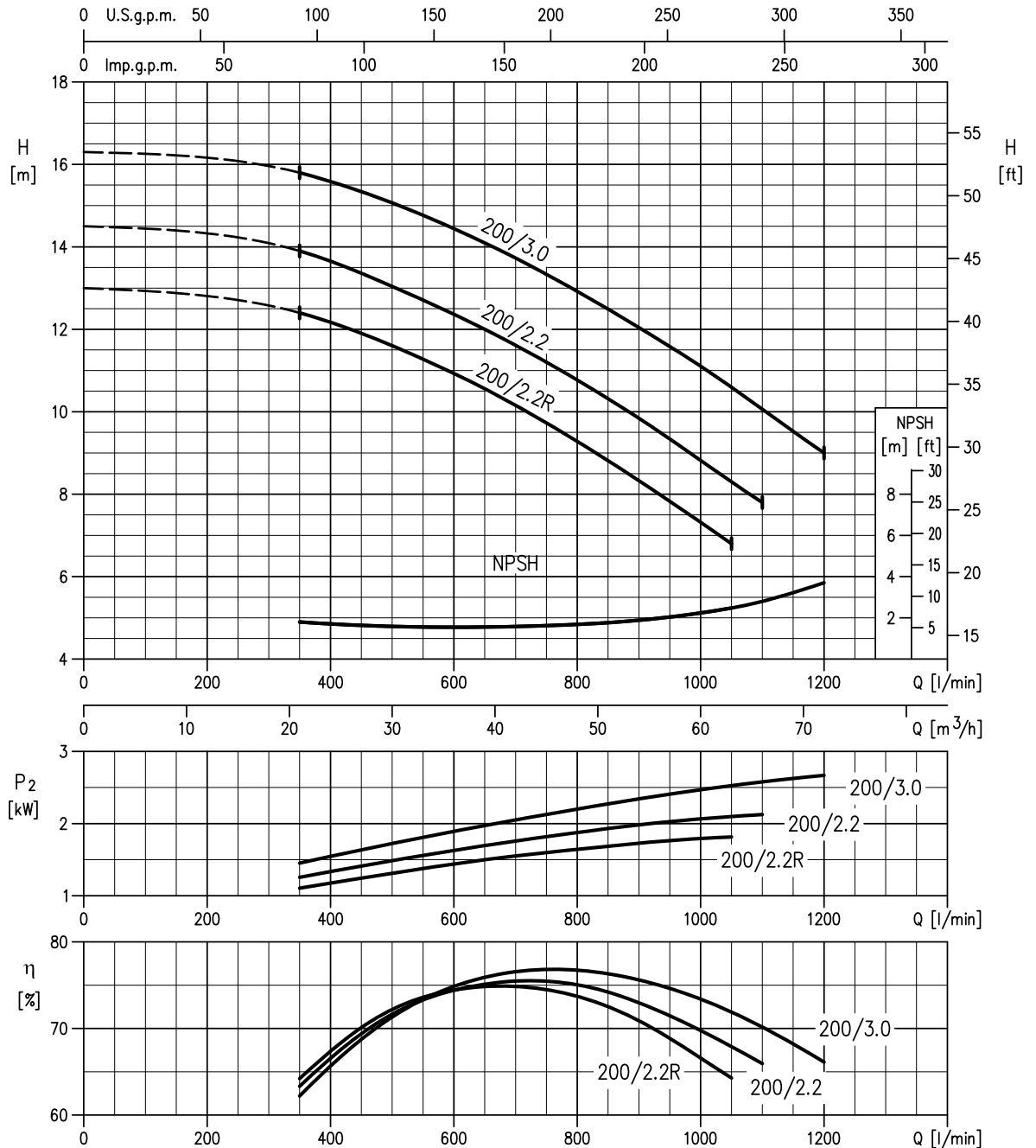

Rotation speed  $\approx 1400 \text{ min}^{-1}$   
 Test standard: ISO 9906:2012 – Grade 3B



65-250/4 (4.0 kW) – impeller diameter = 235 mm  
 65-250/5.5 (5.5 kW) – impeller diameter = 250 mm

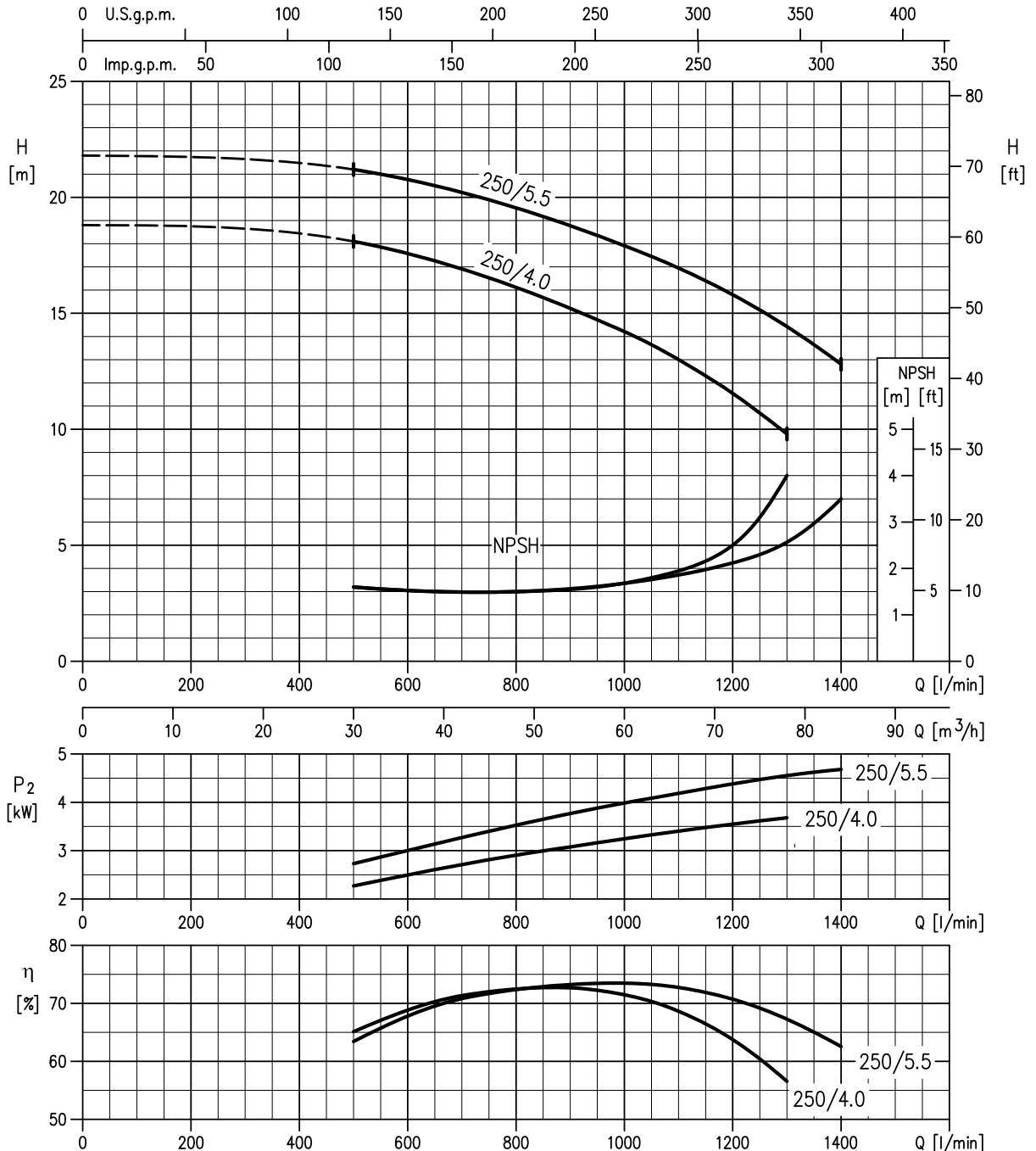

Rotation speed  $\approx 1400 \text{ min}^{-1}$   
 Test standard: ISO 9906:2012 – Grade 3B

80-160/1.5 (1.5 kW) – impeller diameter = 156 mm  
 80-160/2.2R (2.2 kW) – impeller diameter = 165 mm  
 80-160/2.2 (2.2 kW) – impeller diameter = 174 mm

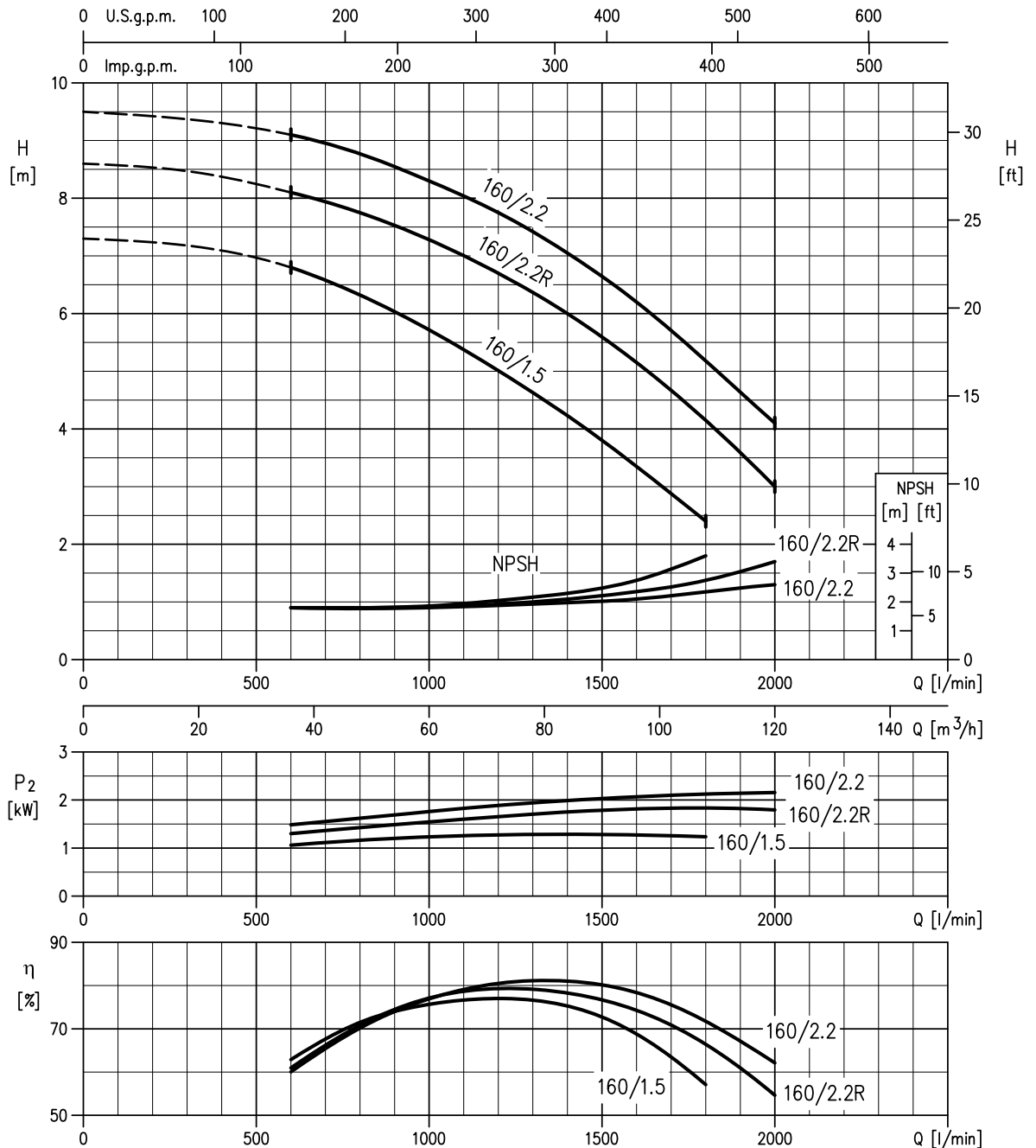

Rotation speed ≈ 1400 min<sup>-1</sup>  
 Test standard: ISO 9906:2012 – Grade 3B

80-200/3 (3.0 kW) – impeller diameter = 196 mm  
 80-200/4R (4.0 kW) – impeller diameter = 211 mm  
 80-200/4 (4.0 kW) – impeller diameter = 219 mm

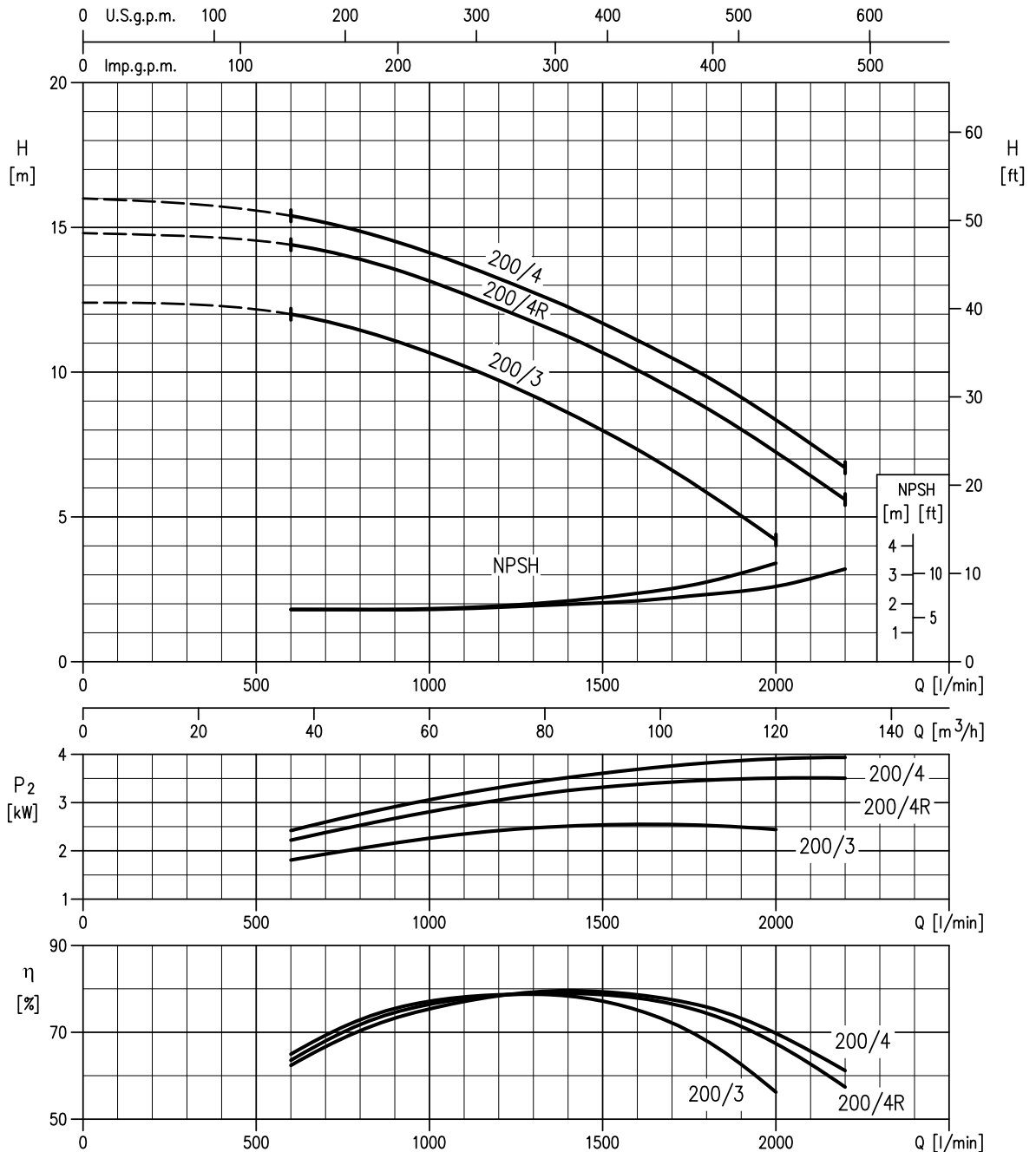

Rotation speed  $\approx 1400 \text{ min}^{-1}$   
 Test standard: ISO 9906:2012 – Grade 3B

80-250/5.5R (5.5 kW) – impeller diameter = 230 mm  
 80-250/5.5 (5.5 kW) – impeller diameter = 246 mm  
 80-250/7.5 (7.5 kW) – impeller diameter = 263 mm

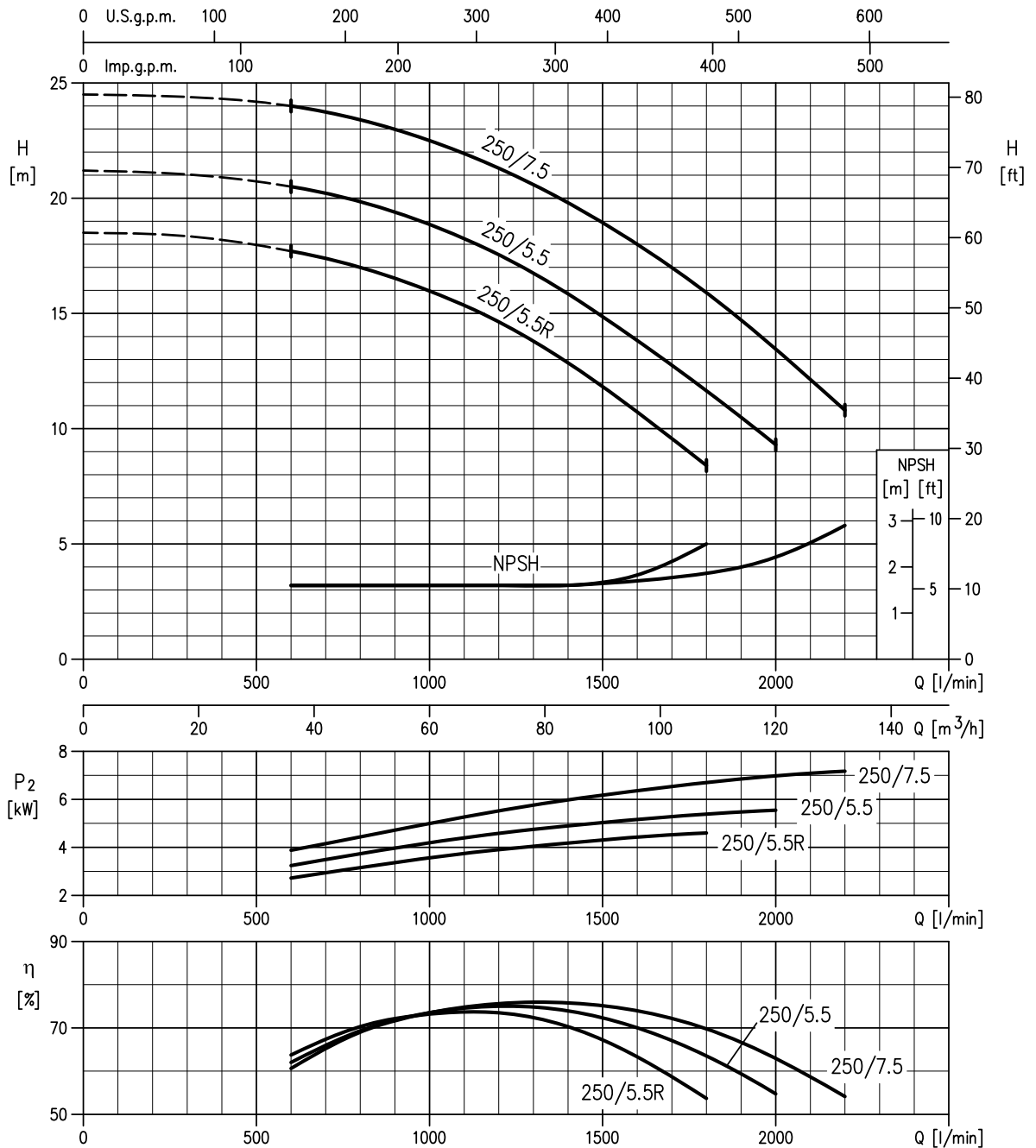

Rotation speed ≈ 1400 min<sup>-1</sup>  
 Test standard: ISO 9906:2012 – Grade 3B

SECTIONAL VIEW DRAWING 3(.)M4 32, 40, 50, 65-125/160/200

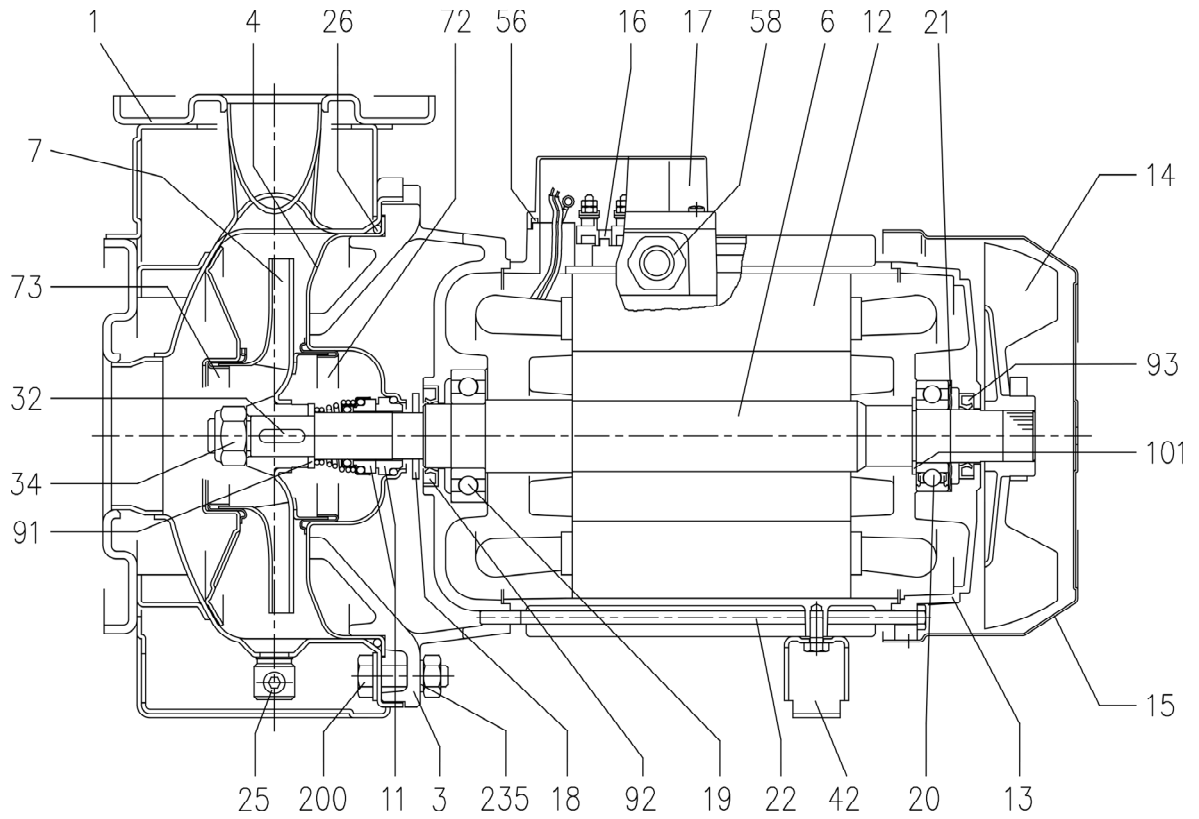

SECTIONAL VIEW TABLE 3(.)M4 32, 40, 50, 65-125/160/200

N°	PART NAME	MATERIAL		DIMENSIONS	STANDARD	Q.TY	
		3M4	3LM4				
1	Casing	EN 1.4301 (AISI 304)	EN 1.4404 (AISI 316L)			1	
3	Motor bracket	[5]				1	
4	Casing cover	EN 1.4301 (AISI 304)	EN 1.4404 (AISI 316L)			1	
6	Shaft with rotor-Part in contact with liquid	EN 1.4301 (AISI 304)	EN 1.4404 (AISI 316L)			1	
7	Impeller	32, 40, 50 65-125/160/200	EN 1.4301 (AISI 304) EN 1.4404 (AISI 316L)	CF8M - EN 1.4408 (AISI 316)		1	
11	Mechanical seal [3]	Carbon/Ceramic/NBR	SiC/SiC/FPM	See p. 321+325		1	
12	Motor frame with stator	-				1	
13	Motor cover	Aluminium				1	
14	Fan	PA				1	
15	Fan cover	Fe P04 Galvanized				1	
16	Terminal	-				1	
17	Terminal box cover	Aluminium (three phase version)				1	
18	Splash ring	NBR	/	40x21.5x3	EBARA DRAWING	1	
19	Bearing	-		See table p.319		1	
20	Bearing	-		See table p.319		1	
21	Adjusting ring	Steel C70				1	
22	Tie rod	Fe 42 Galvanized		M5	EBARA DRAWING	4	
25	Draing plug	EN 1.4401 (AISI 316) / PTFE		R 1/8" L=8	DIN 906	1	
26	"O" ring	32-125, 40-125	NBR [4]	FPM	158.11x5.34	OR 6625	1
		32-160, 40-160, 50-125, 65-160			183.52x5.34	OR 6720	
		32-200, 40-200, 50-160, 50-200, 65-160, 65-200			227.96x5.34	OR 6895	
32	Key	EN 1.4401 (AISI 316)		6x6x25	UNI 6604	1	
34	Impeller nut	Other models	EN 1.4301 (AISI 304)	EN 1.4404 (AISI 316L)	M16x1.5	UNI 7474	1
		50-200/2.2			M18x1.5		
42	Foot	Aluminium / Galvanized steel			EBARA DRAWING	1	
56	Box gasket	NBR				1	
58	Fasting nut	-				1	
72	Casing ring (not for 65 version) [1]	EN 1.4301 (AISI 304)	EN 1.4404 (AISI 316L)			1	
73	Casing ring (not for 65 version)	EN 1.4301 (AISI 304)	EN 1.4404 (AISI 316L)			1	
91	Impeller spacer [6]	EN 1.4404 (AISI 316L)				1	
92	Lip seal	Up to 1.5kW	-	-	25x40x7	DIN 3760 without spring	1
		From 2.2kW to 3kW			30x47x7		
93	Lip seal	For 0.25kW	-	-	15x30x5	DIN 3760 without spring	1
		For 0.37kW and 0.55kW			17x32x7		
		From 0.75 kW to 3kW			25x40x7		
200	Screw	32-125, 40-125	Stainless steel A2 70 class ISO 3506/1		M 8x30	UNI 5739	8
		40-160, 40-200, 50-125, 50-160, 50-200, 65-125, 65-160, 65-200			M 10x35		[2]
235	Washer	32-125, 40-125	EN 1.4301 (AISI 304)		8.4x17	UNI 6592	8
		40-160, 40-200, 50-125, 50-160, 50-200, 65-125, 65-160, 65-200			10.5x21		[2]

Counterflange kit on request, see table p. 328-329

[1] For version 32-200, 40-200, 50-160, 50-200

[2] Quantity = 10 for 32-160, 40-160, 50-125, 65-125

Quantity = 12 for 32-200, 40-200, 50-160, 50-200, 65-160, 65-200

[3] Special version: see page 321 and following

[4] FPM (H-HS-HW-HSW version)

EPDM (E version)

[5] Aluminum AL-EN-1706-AC-46000-D for 3D4 50-200/2.2; 65-125/0.75 and 1.1; 65-160/2.2; 65-200/2.2 and 3 kW

Cast iron EN-GJL-200-EN 1561 for all the others;

[6] Only for 32-125/0.25

SECTIONAL VIEW DRAWING 3LM4 80-160

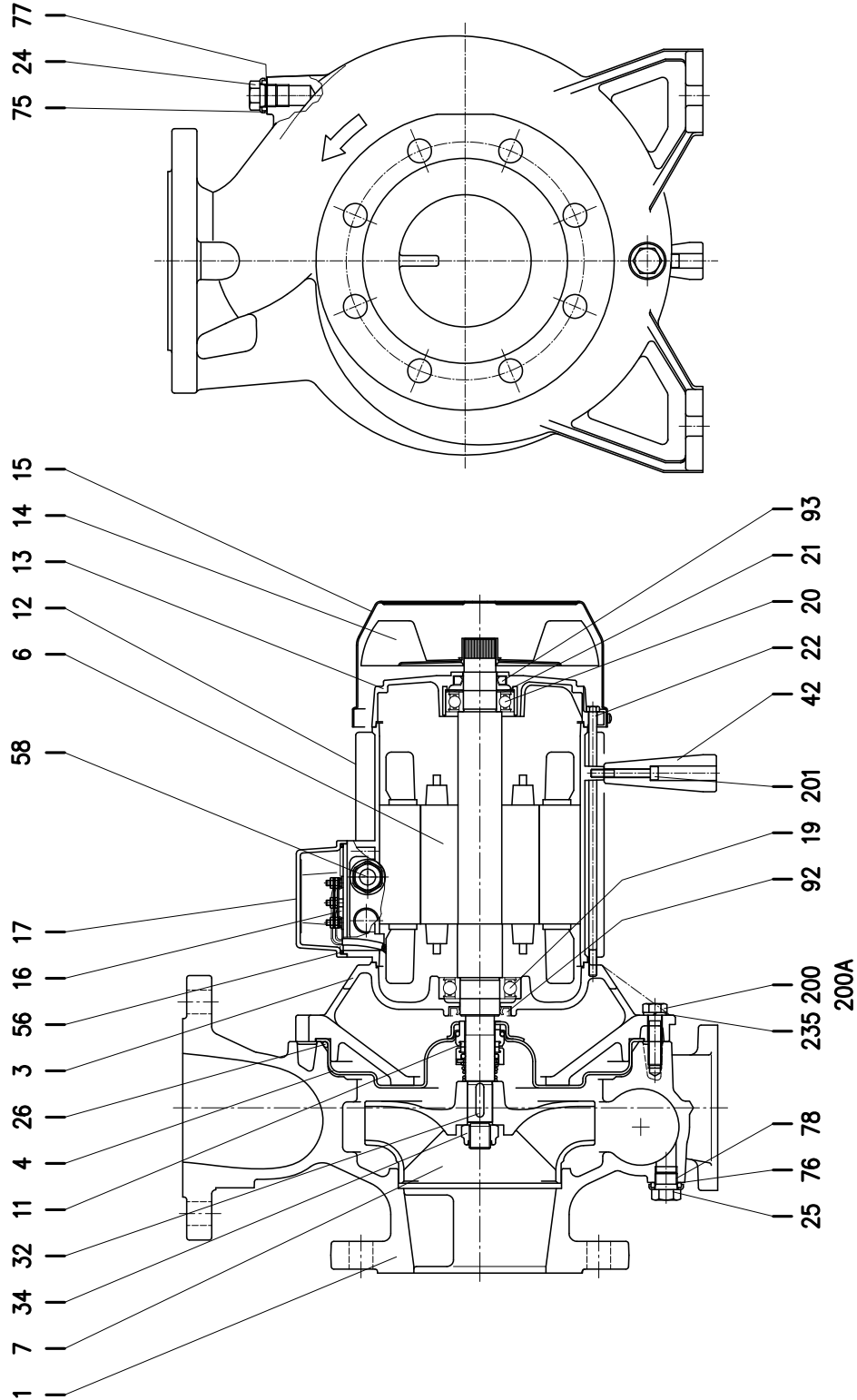

**SECTIONAL VIEW TABLE 3LM4 80-160**

N°	PART NAME		MATERIAL	DIMENSIONS	STANDARD	Q.TY
1	Casing		CF8M - EN 1.4408 (AISI 316)			1
3	Motor bracket		Cast iron EN-GJL-200-EN 1561			1
4	Casing cover		EN 1.4404 (AISI 316L)			1
6	Shaft with rotor		EN 1.4404(AISI 316L) -Part in contact with liquid			1
7	Impeller		CF8M - EN 1.4408 (AISI 316)			1
11	Mechanical seal [1]		SiC/SiC/FPM	See p. 321+325		1
12	Motor frame with stator		-			1
13	Motor cover		Aluminium			1
14	Fan		PA			1
15	Fan cover		Fe P04 Galvanized			1
16	Terminal		-			1
17	Terminal box cover		Aluminium			1
19	Bearing		-	See table p. 319		1
20	Bearing		-	See table p. 319		1
21	Adjusting ring		Steel C70			1
22	Tie rod		Fe 42 Galvanized			4
24	Plug		EN 1.4404 (AISI 316L)	G 3/8	EPE DRAWING	1
25	Plug		EN 1.4404 (AISI 316L)	G 3/8	EPE DRAWING	1
26	"O" ring		FPM	227.96x5.34	OR 6895	1
32	Key		EN 1.4404 (AISI 316L)	6x6x25	UNI 6604	1
34	Impeller nut		EN 1.4404 (AISI 316L)	M16x1.5	UNI 7474	1
42	Foot		Aluminium		EPE DRAWING	1
56	Box gasket		NBR			1
58	Fastening nut		-			1
75	Washer (plug)		EN 1.4404 (AISI 316L)			1
76	Washer (plug)					1
77	O-ring (plug)		FPM [2]			1
78	O-ring (plug)					1
92	Lip seal	1.5 kW	-	25x40x7	DIN 3760 without spring	1
		2.2 kW		30x47x7		
93	Lip seal		-	25x40x7		1
200	Screw		Stainless steel A2-70 class ISO 3506/1	M 10x35	UNI 5739	10
200A	Screw			M 10x30		2
201	Screw	1.5 kW	Stainless steel A2-70 class ISO 3506/1	M 6x40	UNI 5739	1
		2.2 kW		M 12x40		4
235	Washer		EN 1.4301 (AISI 304)	10.5	UNI 6592	12

Counterflange kit on request, see p. 328-329

[1] Special version: see page 321 and following

[2] EPDM (E version)



SECTIONAL VIEW DRAWING 3LM4 65-250, 80-200/250

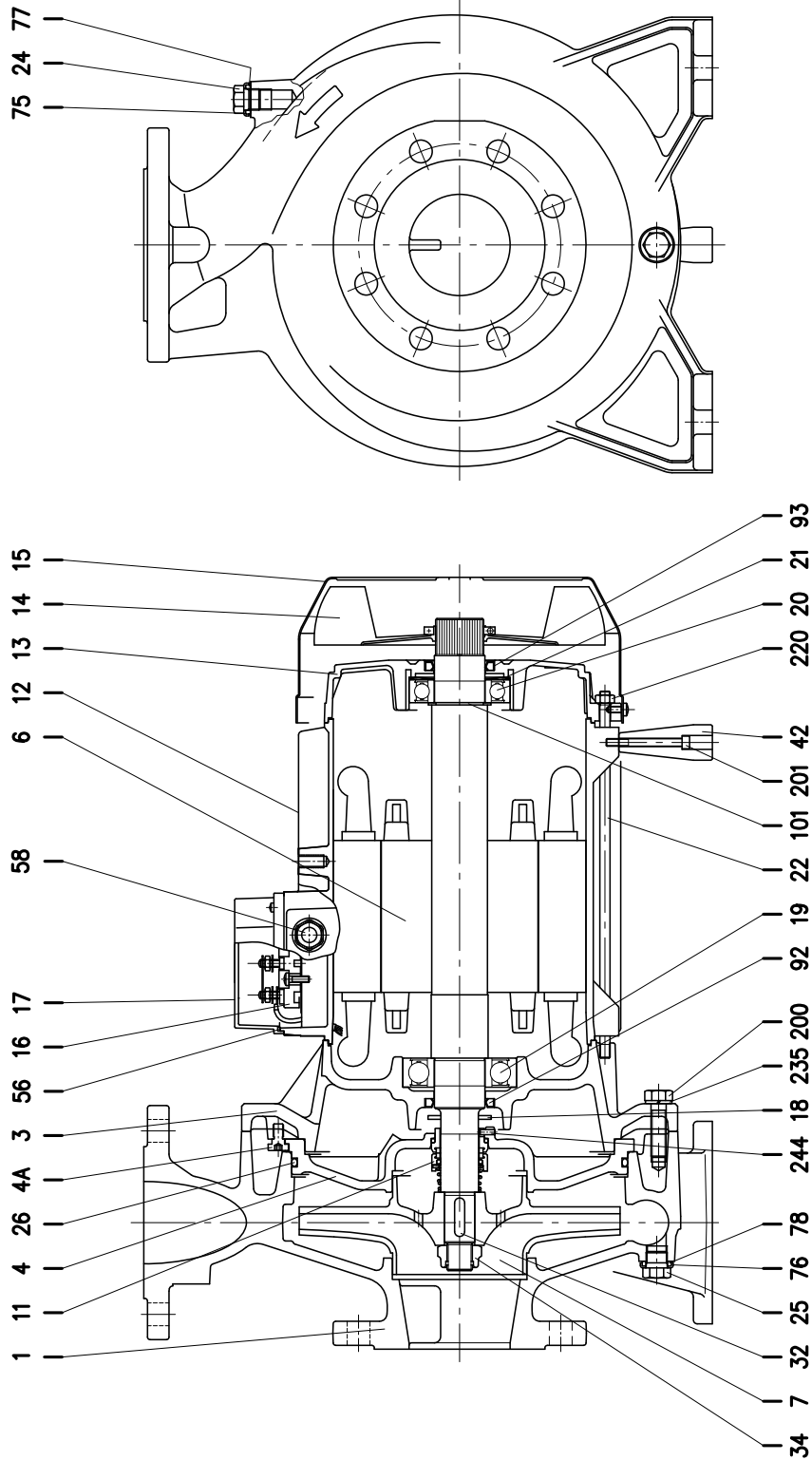

**SECTIONAL VIEW TABLE 3LM4 65-250, 80-200/250**

N°	PART NAME	MATERIAL	DIMENSIONS	STANDARD	Q. TY
1	Casing	CF8M - EN 1.4408 (AISI 316)			1
3	Motor bracket	Cast iron EN-GJL-200-EN 1561			1
4	Casing cover	EN 1.4401 (AISI 316)			1
004A	Screw for casing cover	EN 1.4301 (AISI 304)			2
6	Shaft with rotor	EN 1.4404(AISI 316L) -Part in contact with liquid			1
7	Impeller	CF8M - EN 1.4408 (AISI 316)			1
11	Mechanical seal [2]	SiC/SiC/FPM	See p. 321+325		1
12	Motor frame with stator	-			1
13	Motor cover	Aluminium			1
14	Fan	PA			1
15	Fan cover	Fe P04 Galvanized			1
16	Terminal	-			1
17	Terminal box cover	Aluminium			1
18	Splash ring	NBR	50x29.5x3	EPE DRAWING	1
19	Bearing	-	See table p. 319		1
20	Bearing	-	See table p. 319		1
21	Adjusting ring	Steel C70			1
22	Tie rod	Fe 42 Galvanized			4
24	Plug	EN 1.4404 (AISI 316L)	G 3/8	EPE DRAWING	1
25	Plug	EN 1.4404 (AISI 316L)	G 3/8	EPE DRAWING	1
26	"O" ring	FPM	227.96x5.34	OR 6895	1
32	Key	EN 1.4404 (AISI 316L)	8x7x30	UNI 6604	1
34	Impeller nut	Aluminium	M20x1.5	UNI 7474	1
42	Foot	Aluminium		EPE DRAWING	1
56	Box gasket	NBR			1
58	Fasting nut	-			1
75	Washer (plug)				1
76	Washer (plug)	EN 1.4404 (AISI 316L)			1
77	O-ring (plug)				1
78	O-ring (plug)	FPM [3]			1
92	Lip seal	3 - 4 kW	30x47x7	DIN 3760	1
		5.5 kW	40x55x7	without spring	
93	Lip seal	3 kW	25x40x7	DIN 3760	1
		4 kW	30x47x7	without spring	
		5.5 kW	40x55x7		
101	Snap ring (only 5.5 kW)	Carbon tool steels TC 80	Ø 40	UNI 7435	1
200	Screw	Stainless steel A2-70 class ISO 3506/1	M 12x45	UNI 5739	10
201	Screw	for 80-200/4 kW	M 6x12	UNI 5739	1
		for 80-200/3 kW	M 6x45		
		for the other versions	M 6x60		
220	Nut for tie rod (only 5.5 kW)	Galvanized steel	M8		4
235	Washer	EN 1.4301(AISI 304)	13	UNI 8842	10
244	Pin [1]	EN 1.4301(AISI 304)	4x12		1

Counterflange kit on request, see table p. 328-329

[1] Not for H, HW, HSW and E options

[2] Special version: see page 321 and following

[3] EPDM (E version)

SECTIONAL VIEW DRAWING 3(.)S4 32, 40, 50, 65-125/160/200

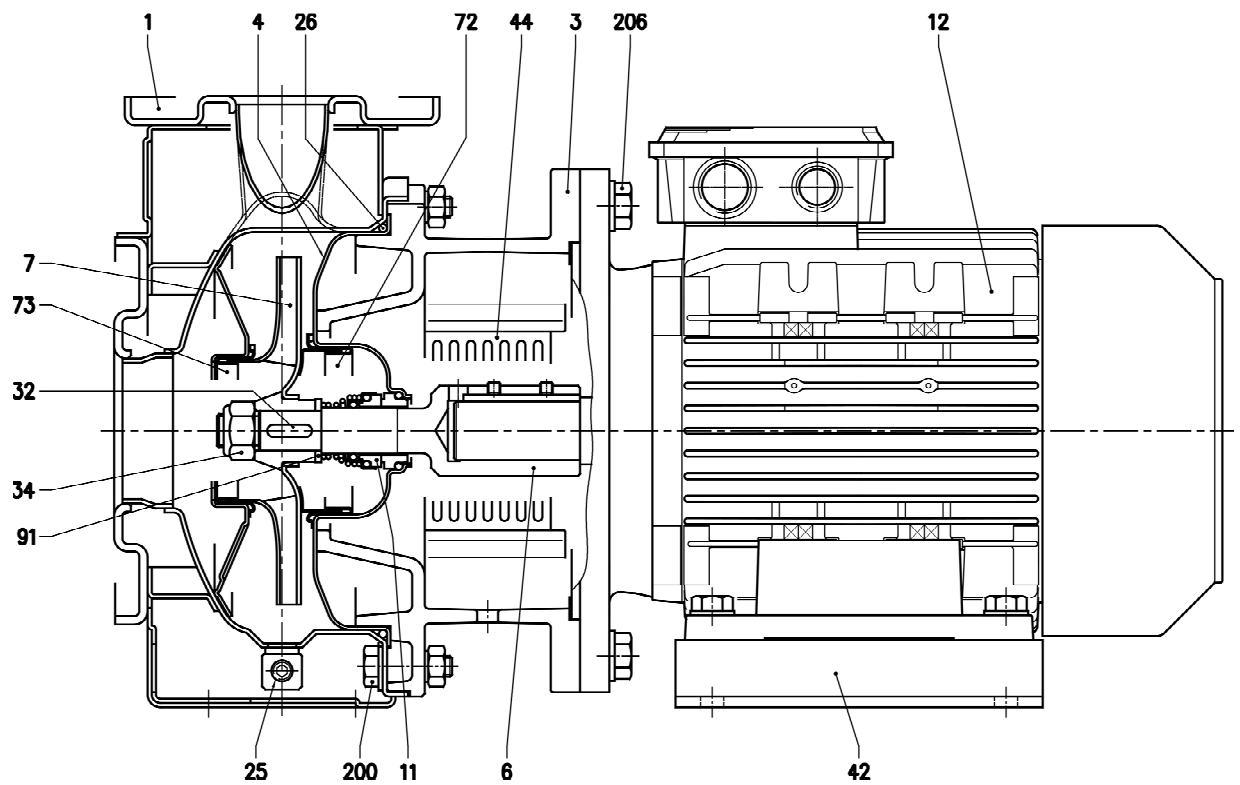

**SECTIONAL VIEW TABLE 3(.)S4 32, 40, 50, 65-125/160/200**

N°	PART NAME	MATERIAL		DIMENSIONS	STANDARD	Q.TY	
		3S4	3LS4				
1	Casing	EN 1.4301 (AISI 304)	EN 1.4404 (AISI 316L)			1	
3	Motor bracket	Cast iron EN-GJL-200-EN 1561				1	
4	Casing cover	EN 1.4301 (AISI 304)	EN 1.4404 (AISI 316L)			1	
6	Coupling - Part in contact with liquid	EN 1.4301 (AISI 304)	EN 1.4404 (AISI 316L)	See table p. 326		1	
7	Impeller	32, 40, 50 65-125/160/200	EN 1.4301 (AISI 304) EN 1.4404 (AISI 316L)			1	
11	Mechanical seal [4]	Carbon/Ceramic/NBR	SiC/SiC/FPM	See p. 321+325		1	
12	Motor	-				1	
25	Draining plug	EN 1.4401 (AISI 316) / PTFE		R 1/8" L=8	DIN 906	1	
26	"O" ring	32-125, 40-125	NBR [5]	FPM	158.11x5.34	OR 6625	1
		32-160, 40-160, 50-125, 65-125			183.52x5.34	OR 6720	
		32-200, 40-200, 50-160, 50-200, 65-160, 65-200			227.96x5.34	OR 6895	
32	Key	EN 1.4401 (AISI 316)		6x6x25	UNI 6604	1	
34	Impeller nut	Other model 50-200/2.2	EN 1.4301 (AISI 304)	EN 1.4404 (AISI 316L)	M16x1.5 M18x1.5	UNI 7474	1
42	Foot	Galvanized steel				[1]	
44	Protection	EN 1.4301 (AISI 304)			EBARA DRAWING	2	
72	Casing ring (not for 65 version) [2]	EN 1.4301 (AISI 304)	EN 1.4404 (AISI 316L)			1	
73	Casing ring (not for 65 version)	EN 1.4301 (AISI 304)	EN 1.4404 (AISI 316L)			1	
91	Impeller spacer [6]	EN 1.4404 (AISI 316L)				1	
200	Screw	32-125, 40-125	Stainless steel A2 70 class ISO 3506/1		M 8x30	UNI 5739	8
		40-160, 40-200, 50-125, 50-160, 50-200, 65-125, 65-160, 65-200			M 10x35	UNI 5739	
206	Screw	up to 0.37kW	Gv. Steel 8.8 strenght class ISO 898/1		M 8x20	UNI 5739	4
		from 0.55 to 1.5kW			M 10x25		
		for 2.2 and 3kW			M 12x30		

Counterflange kit on request see p. 328-329

[1] Quantity = 1 up to 1.5kW

Quantity = 2 for 2.2 and 3kW

[2] Only for version 32-200, 40-200, 50-160, 50-200

[3] Quantity = 10 for 32-160, 40-160, 50-125, 65-125

Quantity = 12 for 32-200, 40-200, 50-160, 50-200, 65-160, 65-200

[4] Special version: see page 321 and following

[5] FPM (H-HS-HW-HSW version)

EPDM (E version)

[6] Only for 32-125/0.25

SECTIONAL VIEW DRAWING 3LS4 80-160

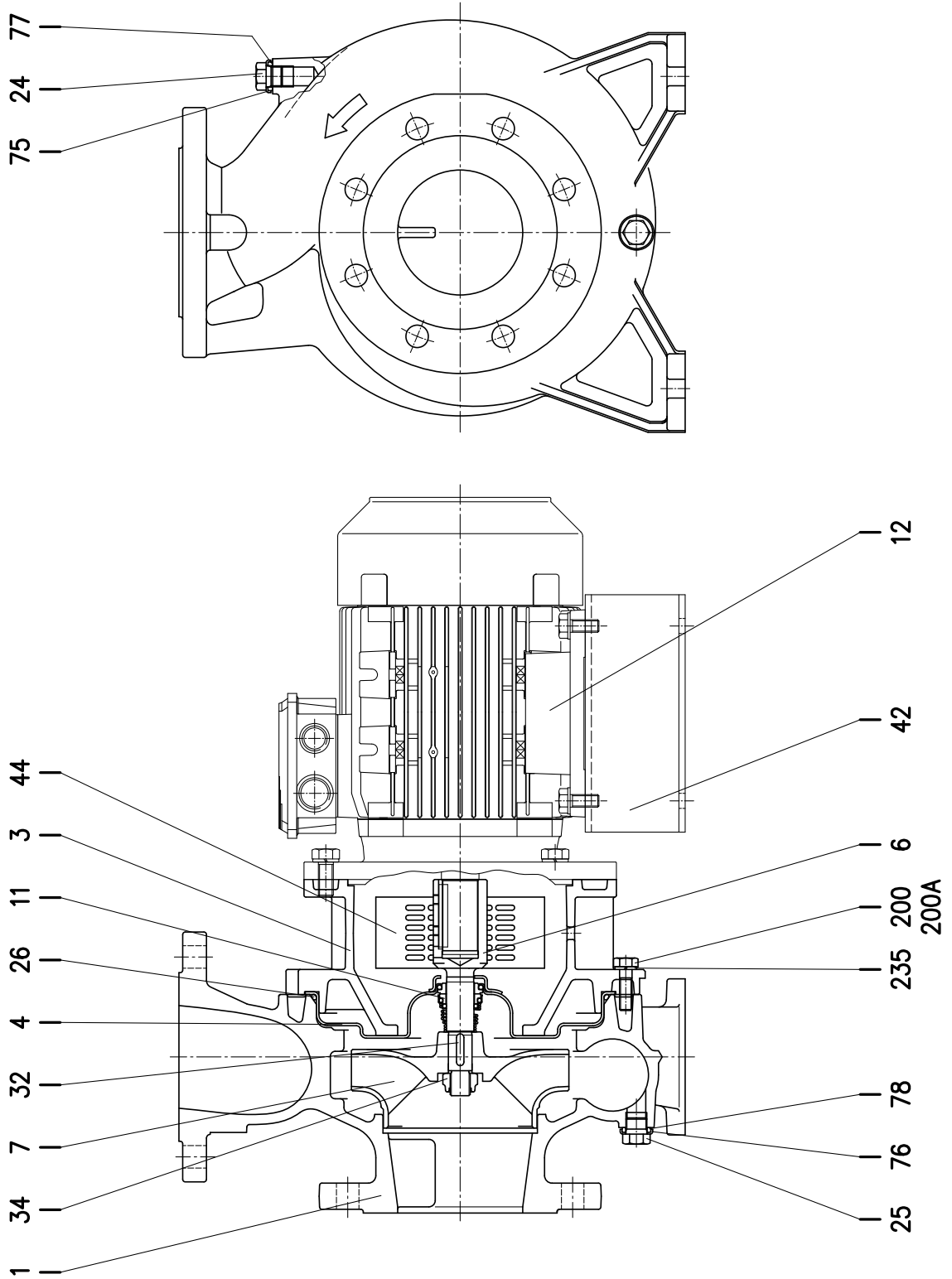

**SECTIONAL VIEW TABLE 3LS4 80-160**

N°	PART NAME	MATERIAL	DIMENSIONS	STANDARD	Q.TY
1	Casing	CF8M - EN 1.4408 (AISI 316)			1
3	Motor bracket	Cast iron EN-GJL-200-EN 1561			1
4	Casing cover	EN 1.4404 (AISI 316L)			1
6	Coupling	EN 1.4404 (AISI 316L)	See table p. 326		1
7	Impeller	CF8M - EN 1.4408 (AISI 316)			1
11	Mechanical seal [1]	SiC/SiC/FPM	See p. 321+325		1
12	Motor	-			1
24	Plug	EN 1.4404 (AISI 316L)	G3/8	EPE DRAWING	1
25	Plug	EN 1.4404 (AISI 316L)	G3/8	EPE DRAWING	1
26	"O" ring	FPM EPDM (E option)	227.96x5.34	OR 6895	1
32	Key	EN 1.4401 (AISI 316)	6x6x25	UNI 6604	1
34	Impeller nut	EN 1.4404 (AISI 316L)	M16x1.5	UNI 7474	1
42	Foot	Galvanized steel		EPE DRAWING	1
44	Protection	EN 1.4301 (AISI 304)		EPE DRAWING	2
75	Washer (plug)	EN 1.4404 (AISI 316L)			1
76	Washer (plug)				1
77	O-ring (plug)	FPM [2]			1
78	O-ring (plug)				1
200	Screw	Stainless steel A2-70 class ISO 3506/1	M 10x35	UNI 5739	10
200A	Screw		M 10x30		2
235	Washer	EN 1.4301 (AISI 304)	10.5	UNI 6592	12

Counterflange kit on request, see table p. 328-329

[1] Special version: see page 321 and following

[2] EPDM (E version)

SECTIONAL VIEW DRAWING 3LS4 65-250, 80-200/250

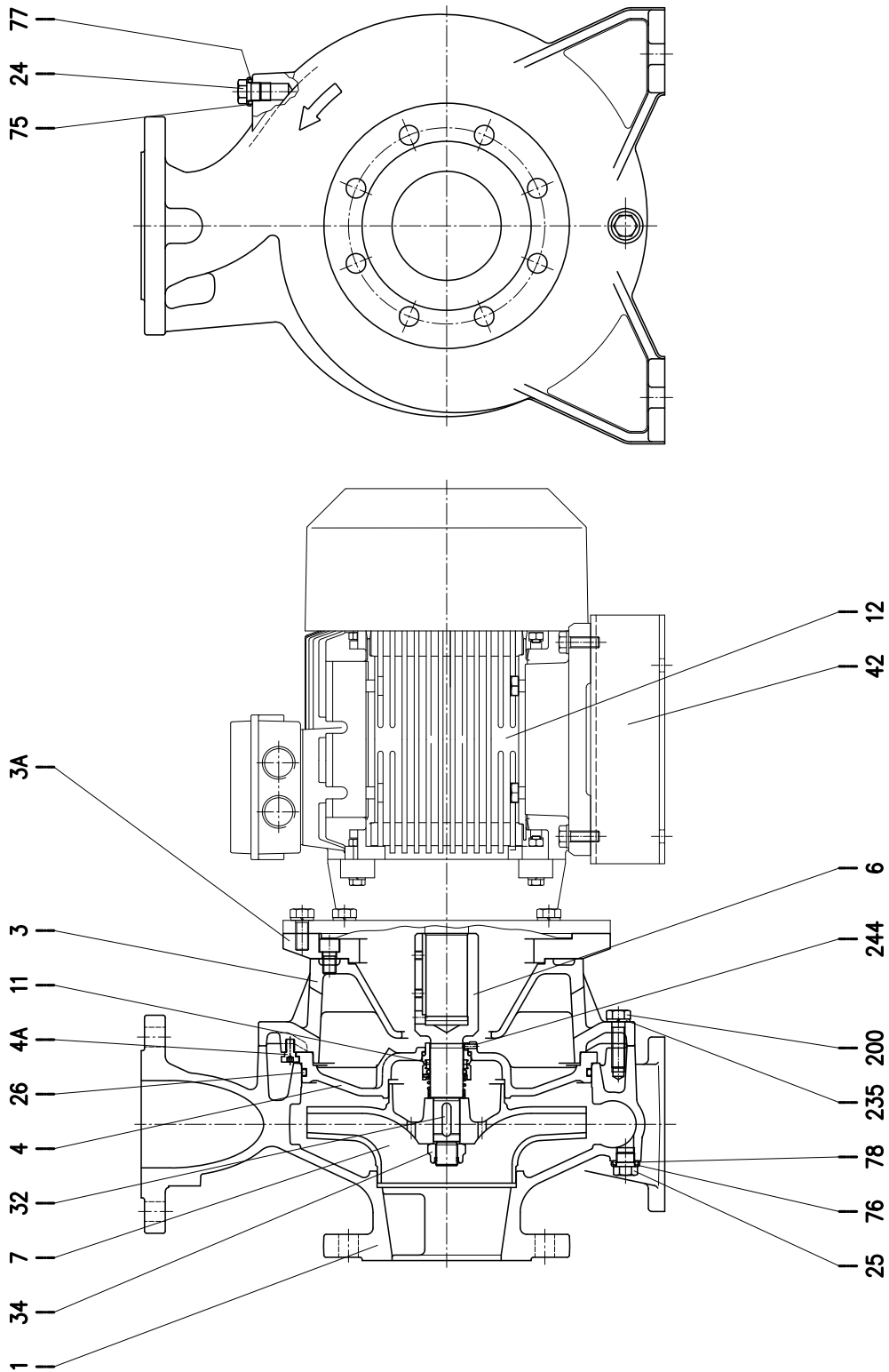

**SECTIONAL VIEW TABLE 3LS4 65-250, 80-200/250**

N°	PART NAME	MATERIAL	DIMENSIONS	STANDARD	Q.TY
1	Casing	CF8M - EN 1.4408 (AISI 316)			1
3	Motor bracket	Cast iron EN-GJL-200-EN 1561			1
003A	Adapter ring [1]	Cast iron EN-GJL-200-EN 1561			1
4	Casing cover	EN 1.4401 (AISI 316)			1
004A	Screw for casing cover	EN 1.4301(AISI 304)			2
6	Coupling	EN 1.4401 (AISI 316)	See table p. 326		1
7	Impeller	CF8M - EN 1.4408 (AISI 316)			1
11	Mechanical seal [3]	SiC/SiC/FPM	See p. 321+325		1
12	Motor	-			1
24	Plug	EN 1.4404 (AISI 316L)	G3/8	EPE DRAWING	1
25	Plug	EN 1.4404 (AISI 316L)	G3/8	EPE DRAWING	1
26	"O" ring	FPM EPDM (E version)	253.36x5.34	OR 6995	1
32	Key	EN 1.4401 (AISI 316)	8x7x30	UNI 6604	1
34	Impeller nut	EN 1.4404 (AISI 316L)	M20x1.5	UNI 7474	1
42	Foot for motor	Galvanized steel		EPE DRAWING	1
75	Washer (plug)	EN 1.4404 (AISI 316L)			1
76	Washer (plug)				
77	O-ring (plug)				1
78	O-ring (plug)		FPM [4]		1
200	Screw	Stainless steel A2-70 class ISO 3506/1	M 12x45	UNI 5739	10
235	Washer	EN 1.4301(AISI 304)	13	UNI 8842	10
244	Pin [2]	EN 1.4301(AISI 304)	4x12		1

Counterflange kit on request, see table p. 328-329

[1] Only for 65-250/5.5 kW

[2] Not for H, HW, HSW and E options

[3] Special version: see page 321 and following

[4] EPDM (E version)



SECTIONAL VIEW DRAWING 3(.)P4 32, 40, 50, 65-125/160/200

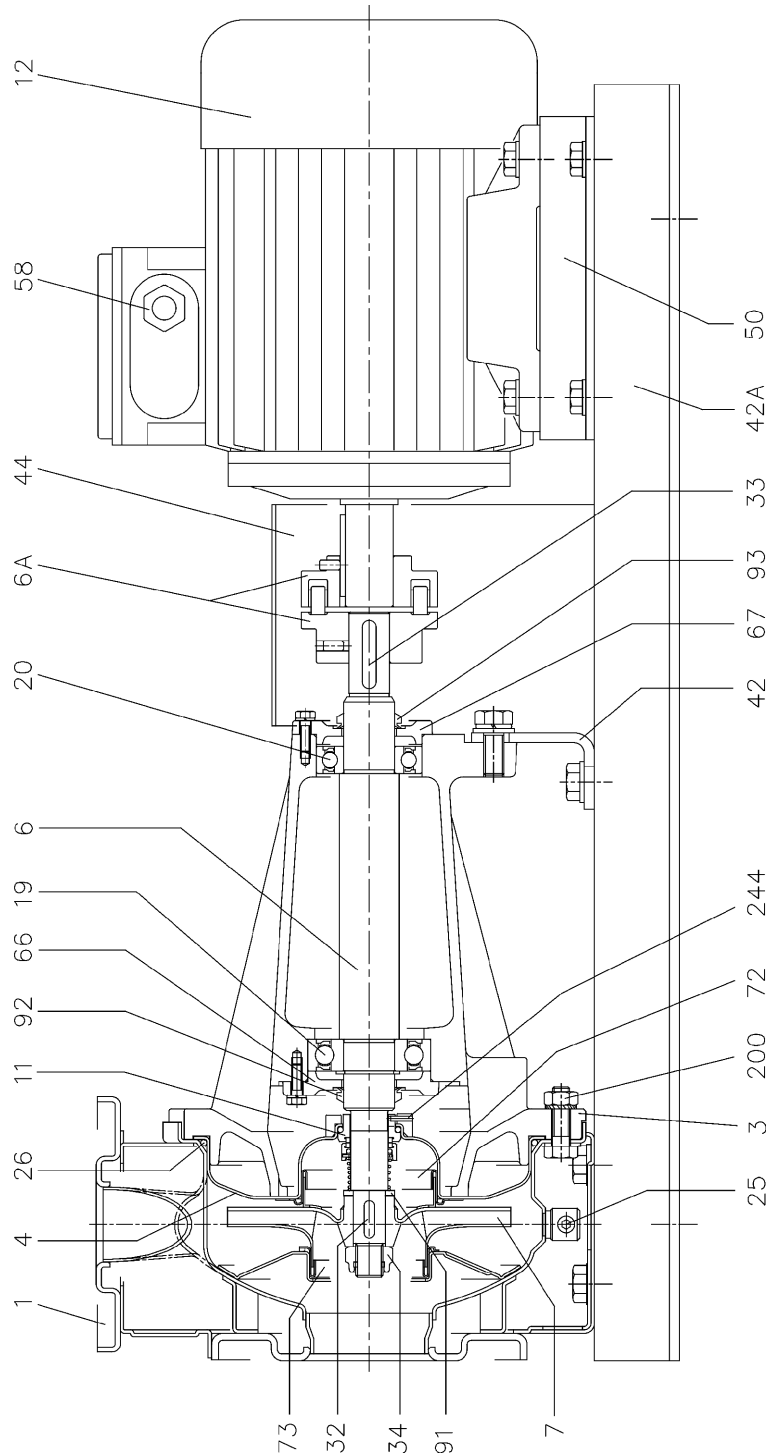

**SECTIONAL VIEW TABLE 3(.)P4 32, 40, 50, 65-125/160/200**

N°	PART NAME		MATERIAL		DIMENSIONS	STANDARD	Q.TY
			3P4	3LP4			
1	Casing		EN 1.4301 (AISI 304)	EN 1.4404 (AISI 316L)			1
3	Support		Cast iron EN-GJL-200-EN 1561				1
4	Casing cover		EN 1.4301 (AISI 304)	EN 1.4404 (AISI 316L)			1
6	Shaft - Part in contact with liquid		EN 1.4301 (AISI 304)	EN 1.4404 (AISI 316L)			1
006 A	Flexible coupling		Cast iron EN-GJL-250-EN 1561		See table pag. 327		1
7	Impeller	32-40-50 65-125/160/200	EN 1.4301 (AISI 304)	EN 1.4404 (AISI 316L)			1
11	Mechanical seal	[3]	Carbon/Ceramic/NBR	SiC/SiC/FPM	See p. 321+325		1
12	Motor		-				1
19	Bearing		-		See table p. 320		1
20	Bearing		-		See table p. 320		1
25	Draing plug		EN 1.4401 (AISI 316) / PTFE		R 1/8" L=8	DIN 906	1
26	"O" ring	32-125, 40-125	NBR [4]	FPM	158.11x5.34	OR 6625	1
		32-160, 40-160, 50-125, 65-125			183.52x5.34	OR 6720	
		32-200, 40-200, 50-160, 50-200, 65-160, 65-200			227.96x5.34	OR 6895	
32	Key		EN 1.4401 (AISI 316)		6x6x25	UNI 6604	1
33	Key		C 40		8x7x40	UNI 6604	1
34	Impeller nut	Other model 50-200/2.2	EN 1.4301 (AISI 304)	EN 1.4404 (AISI 316L)	M16x1.5 M18x1.5	UNI 7474	1
42	Pump support		Galvanized steel			EBARA DRAWING	1
042 A	Base		Galvanized steel				1
44	Protection		Galvanized steel				1
50	Foot		Galvanized steel				1
58	Fasting nut		-				1
66	Impeller side bearing cover		Cast iron EN-GJL-200-EN 1561				1
67	Motor side bearing cover		Cast iron EN-GJL-200-EN 1561				1
72	Casing ring (not for 65 version) [1]		EN 1.4301 (AISI 304)	EN 1.4404 (AISI 316L)			1
73	Casing ring (not for 65 version)		EN 1.4301 (AISI 304)	EN 1.4404 (AISI 316L)			1
89	Snap ring	32-125, 32-160, 40-125, 50-125	Carbon tool steel TC 80		Ø30	UNI 7435	1
		Other model			Ø40		
91	Impeller spacer [5]		EN 1.4404 (AISI 316L)				1
92	"V" ring		-		VS - 0030		1
93	"V" ring		-		VS - 0030		1
200	Screw	32-125, 40-125	Stainless steel A2 70 class ISO 3506/1		M 8x30	UNI 5739	8
		40-160, 40-200, 50-125, 50-160, 50-200, 65-125, 65-160, 65-200			M 10x35	UNI 5739	[2]

Counterflange kit on request see p. 328-329

[1] For version: 32-200, 40-200, 50-160, 50-200

[2] Quantity = 10 for 32-160, 40-160, 50-125, 65-125

Quantity = 12 for 32-200, 40-200, 50-160, 50-200, 65-160, 65-200

[3] Special version: see page 321 and following

[4] FPM (H-HS-HW-HSW version)

EPDM (E version)

[5] Only for 32-125/0.25

SECTIONAL VIEW DRAWING 3LP4 80-160

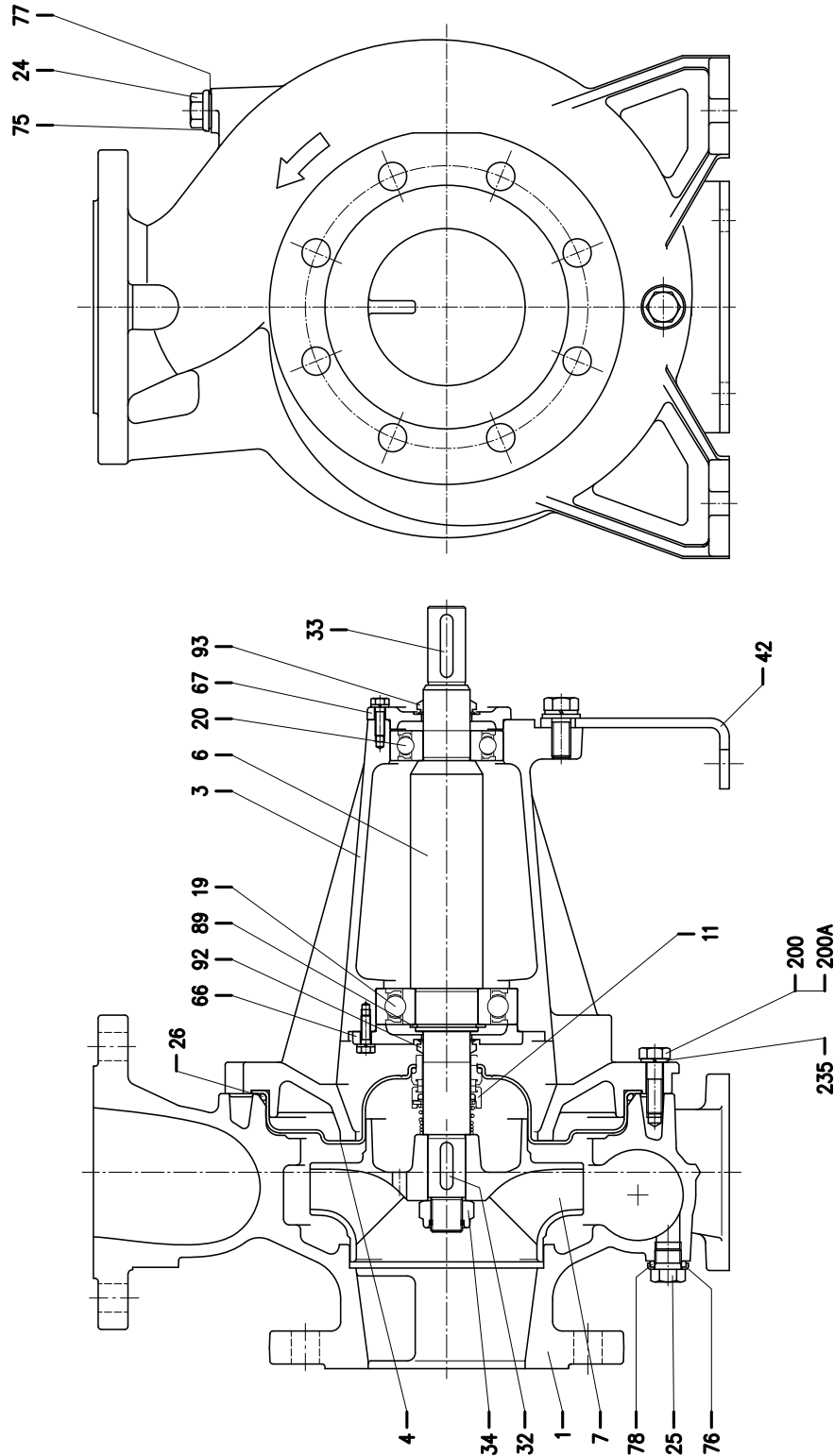

SECTIONAL VIEW DRAWING 3LP4 65-250, 80-200/250

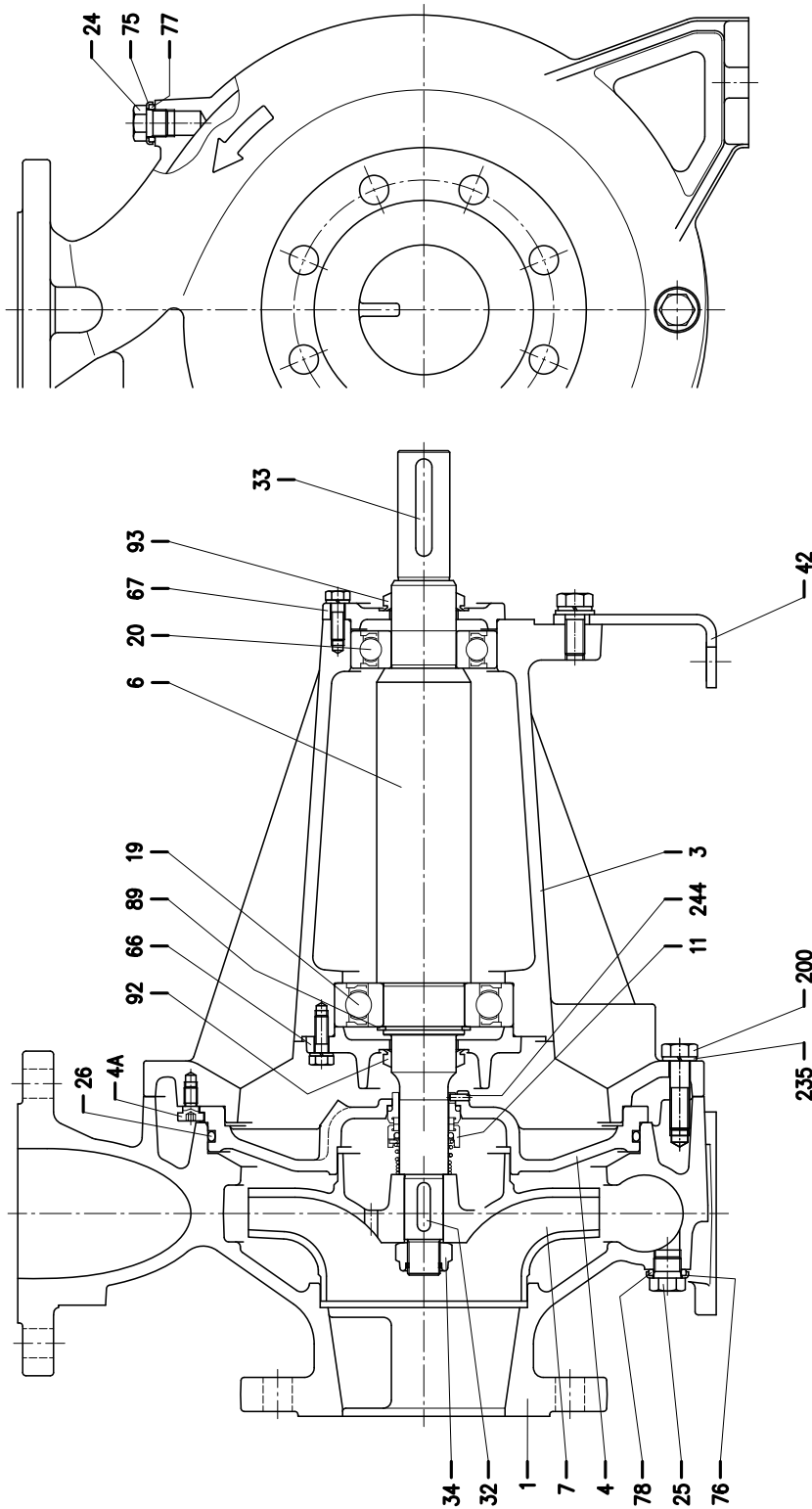

SECTIONAL VIEW DRAWING 3LP4 65-250, 80-160/200/250

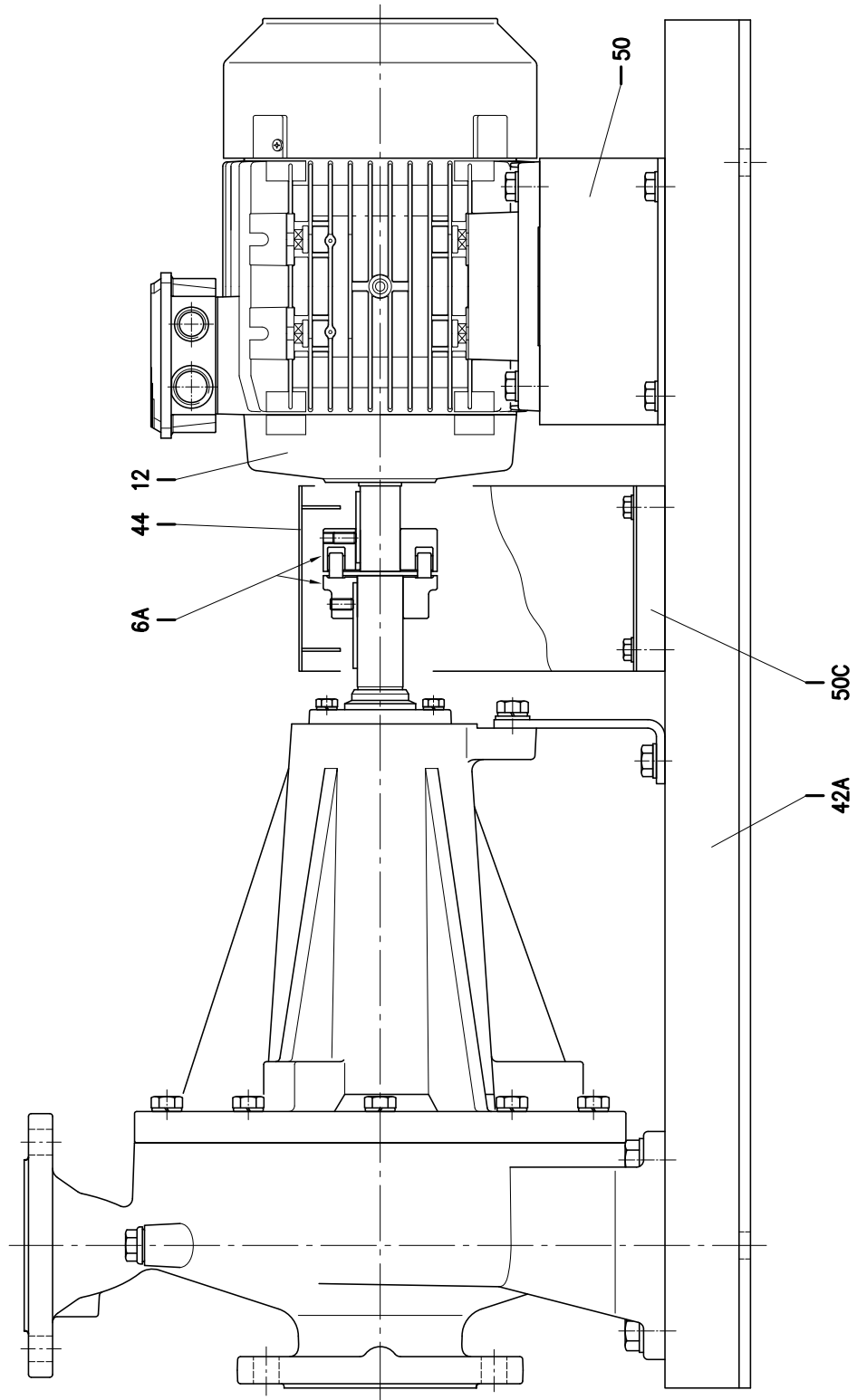

**SECTIONAL VIEW TABLE 3LP4 80-160**

N°	PART NAME	MATERIAL	DIMENSIONS	STANDARD	Q.TY
1	Casing	CF8M - EN 1.4408 (AISI316)			1
3	Support	Cast iron EN-GJL-200-EN 1561			1
4	Casing cover	EN 1.4404 (AISI316L)			1
6	Shaft	EN 1.4404 (AISI316L)-Part in contact with liquid			1
006A	Flexible coupling	Cast iron EN-GJL-250-EN 1561	See table p. 327		1
7	Impeller	CF8M - EN 1.4408 (AISI316)			1
11	Mechanical seal [2]	SiC/SiC/FPM	See p. 321+325		1
12	Motor	-			1
19	Bearing	-	See table p. 320		1
20	Bearing	-	See table p. 320		1
24	Plug	EN 1.4404 (AISI316L)	G3/8	EPE DRAWING	1
25	Plug	EN 1.4404 (AISI316L)	G3/8	EPE DRAWING	1
26	"O" ring	FPM EPDM (E option)	227.96x5.34	OR 6895	1
32	Key	EN 1.4401 (AISI 316)	6x6x25	UNI 6604	1
33	Key	C 40	8x7x40		1
34	Impeller nut	EN 1.4404 (AISI 316L)	M16x1.5	UNI 7474	1
42	Pump support	Galvanized steel		EPE DRAWING	1
042A	Base	Galvanized steel		EPE DRAWING	1
44	Protection	Galvanized steel		EPE DRAWING	1
50	Foot	Galvanized steel		EPE DRAWING	2
050C	Spacer for protection [1]	Aluminium			2
66	Impeller side bearing cover	Cast iron EN-GJL-200-EN 1561			1
67	Motor side bearing cover	Cast iron EN-GJL-200-EN 1561			1
75	Washer (plug)	EN 1.4404 (AISI 316L)			1
76	Washer (plug)				1
77	O-ring (plug)	FPM [3]			1
78	O-ring (plug)				1
89	Snap ring	Carbon tool steels TC 80	Ø 40	UNI 7435	1
92	"V" ring	-	VS-0030		1
93	"V" ring				1
200	Screw	Stainless steel A2 70 class ISO 3506/1	M 10x35	UNI 5739	10
200A	Screw		M 10x30		2
235	Washer	EN 1.4301 (AISI 304)	10.5	UNI 6592	12

Counterflange kit on request see p 328-329

[1] Only for 1.5kW

[2] Special version: see page 321 and following

[3] EPDM (E version)

See p 314-316

## SECTIONAL VIEW TABLE 3LP4 65-250, 80-200/250

N°	PART NAME	MATERIAL	DIMENSIONS	STANDARD	Q.TY
1	Casing	CF8M - EN 1.4408 (AISI316)			1
3	Support	Cast iron EN-GJL-200-EN 1561			1
4	Casing cover	EN 1.4401 (AISI316)			1
004A	Screw for casing cover	EN 1.4301 (AISI 304)			2
6	Shaft	EN 1.4462 (Duplex stainless steel)-Part in contact with liquid			1
006A	Flexible coupling	Cast iron EN-GJL-250-EN 1561	See table p. 327		1
7	Impeller	CF8M - EN 1.4408 (AISI316)			1
11	Mechanical seal [3]	SiC/SiC/FPM	See p. 321+325		1
12	Motor	-			1
19	Bearing	-	See table p. 320		1
20	Bearing	-	See table p. 320		1
24	Plug	EN 1.4404 (AISI316L)	G3/8		1
25	Plug	EN 1.4404 (AISI316L)	G3/8		1
26	"O" ring	FPM EPDM (E version)	253.36x5.34	OR 6995	1
32	Key	EN 1.4401 (AISI 316)	8x7x30	UNI 6604	1
33	Key	C 40	10x8x60	UNI 6604	1
34	Impeller nut	EN 1.4404 (AISI 316L)	M20x1.5	UNI 7474	1
42	Pump support	Galvanized steel			1
042A	Base	Galvanized steel			1
44	Protection	Galvanized steel			1
50	Foot	Galvanized steel		EPE DRAWING	1
050C	Spacer for protection [1]	Aluminium			2
66	Impeller side bearing cover	Cast iron EN-GJL-200-EN 1561			1
67	Motor side bearing cover	Cast iron EN-GJL-200-EN 1561			1
75	Washer (plug)	EN 1.4404 (AISI 316L)			1
76	Washer (plug)				1
77	O-ring (plug)	FPM [4]			1
78	O-ring (plug)				1
89	Snap ring	Carbon tool steels TC 80	Ø 50	UNI 7435	1
92	"V" ring	-	VS-0040		1
93	"V" ring				
200	Screw	Stainless steel A2 70 class ISO 3506/1	M 12x45	UNI 5739	10
235	Washer	EN 1.4301 (AISI 304)	13	UNI 8842	10
244	Pin [2]	EN 1.4301 (AISI 304)	4x12	UNI 6873	1

Counterflange kit on request see p 328-329

[1] Only for 65-250/3-4 kW

[2] Not for H, HW, HSW and E options

[3] Special version: see page 321 and following

[4] EPDM (E version)

See p.315-316

## BEARINGS 3(.)M4, 3(.)S4

Pump type	Ball bearing	
	Pump side	Fan side
3(.)M4 32-125/0.25	6205 2DW C3	6202 2DW C3
3(.)M4 32-160/0.37R		6203 2DW C3
3(.)M4 32-160/0.37		
3(.)M4 32-200/0.55R		
3(.)M4 32-200/0.55		
3(.)M4 32-200/0.75	6205-2RSH C3	6205-2RSH C3
3(.)M4 40-125/0.37R	6205 2DW C3	6202 2DW C3
3(.)M4 40-125/0.37		6203 2DW C3
3(.)M4 40-160/0.55R		
3(.)M4 40-160/0.55		
3(.)M4 40-200/1.1R	6205-2RSH C3	6205-2RSH C3
3(.)M4 40-200/1.1		
3(.)M4 40-200/1.5		
3(.)M4 50-125/0.55R	6205 2DW C3	6203 2DW C3
3(.)M4 50-125/0.55		
3(.)M4 50-160/1.1R	6205-2RSH C3	6205-2RSH C3
3(.)M4 50-160/1.1		
3(.)M4 50-200/1.5R		
3(.)M4 50-200/1.5		
3(.)M4 50-200/2.2		
3(.)M4 65-125/0.55	6205 2DW C3	6203 2DW C3
3(.)M4 65-125/0.75	6205-2RSH C3	6205-2RSH C3
3(.)M4 65-125/1.1		
3(.)M4 65-160/1.1		
3(.)M4 65-160/1.5		
3(.)M4 65-160/2.2		
3(.)M4 65-200/2.2R	3606-2RS1 C3	
3(.)M4 65-200/2.2		
3(.)M4 65-200/3.0		
3LM4 65-250/4	6306-2RS1 C3	6206-2RS1 C3
3LM4 65-250/5.5	6308-2RS1 C3	6208-2RS1 C3
3LM4 80-160/1.5	6205-2RS1 C3	6205-2RS1 C3
3LM4 80-160/2.2R	6206-2RS1 C3	
3LM4 80-160/2.2		
3LM4 80-200/3		
3LM4 80-200/4R	6306-2RS1 C3	
3LM4 80-200/4		
3LM4 80-250/5.5R	6308-2RS1 C3	6208-2RS1 C3
3LM4 80-250/5.5		

Pump type	Ball bearing	
	Pump side	Fan side
3(.)S4 32-125/0.25	6203-2Z	6203-2Z
3(.)S4 32-160/0.37R		
3(.)S4 32-160/0.37		
3(.)S4 32-200/0.55R	6204-2Z C3	6204-2Z C3
3(.)S4 32-200/0.55		
3(.)S4 32-200/0.75		
3(.)S4 40-125/0.37R	6203-2Z	6203-2Z
3(.)S4 40-125/0.37		
3(.)S4 40-160/0.55R	6204-2Z C3	6204-2Z C3
3(.)S4 40-160/0.55		
3(.)S4 40-200/1.1R	6205-2Z C3	6205-2Z C3
3(.)S4 40-200/1.1		
3(.)S4 40-200/1.5		
3(.)S4 50-125/0.55R	6204-2Z C3	6204-2Z C3
3(.)S4 50-125/0.55		
3(.)S4 50-160/1.1R	6205-2Z C3	6205-2Z C3
3(.)S4 50-160/1.1		
3(.)S4 50-200/1.5R		
3(.)S4 50-200/1.5		
3(.)S4 50-200/2.2	6206-2Z C3	6206-2Z C3
3(.)S4 65-125/0.55	6204-2Z C3	6204-2Z C3
3(.)S4 65-125/0.75		
3(.)S4 65-125/1.1	6205-2Z C3	6205-2Z C3
3(.)S4 65-160/1.1		
3(.)S4 65-160/1.5		
3(.)S4 65-160/2.2	6206-2Z C3	6206-2Z C3
3(.)S4 65-200/2.2R		
3(.)S4 65-200/2.2		
3(.)S4 65-200/3.0		
3LS4 65-250/4	6306-2Z C3	6306-2Z C3
3LS4 65-250/5.5	6208-2Z C3	6208-2Z C3
3LS4 80-160/1.5	6205-2Z C3	6205-2Z C3
3LS4 80-160/2.2R	6206-2Z C3	6206-2Z C3
3LS4 80-160/2.2		
3LS4 80-200/3		
3LS4 80-200/4R	6306-2Z C3	6306-2Z C3
3LS4 80-200/4		
3LS4 80-250/5.5R	6208-2Z C3	6208-2Z C3
3LS4 80-250/5.5		
3LS4 80-250/7.5		



**BEARINGS 3(.)P4**

Pump type	Ball bearing			
	Pump		Motor	
	Pump side	Motor side	Pump side	Fan side
3(.)P4 32-125/0.25				
3(.)P4 32-160/0.37R	6306-2RS1 C3	6206-2RS1 C3	6203-2Z	6203-2Z
3(.)P4 32-160/0.37				
3(.)P4 32-200/0.55R				
3(.)P4 32-200/0.55	6308-2RS1 C3	6306-2RS1 C3	6204-2Z C3	6204-2Z C3
3(.)P4 32-200/0.75				
3(.)P4 40-125/0.37R			6203-2Z	6203-2Z
3(.)P4 40-125/0.37	6306-2RS1 C3	6206-2RS1 C3		
3(.)P4 40-160/0.55R			6204-2Z C3	6204-2Z C3
3(.)P4 40-160/0.55				
3(.)P4 40-200/1.1R				
3(.)P4 40-200/1.1	6308-2RS1 C3	6306-2RS1 C3	6205-2Z C3	6205-2Z C3
3(.)P4 40-200/1.5				
3(.)P4 50-125/0.55R	6306-2RS1 C3	6206-2RS1 C3	6204-2Z C3	6204-2Z C3
3(.)P4 50-125/0.55				
3(.)P4 50-160/1.1R				
3(.)P4 50-160/1.1			6205-2Z C3	6205-2Z C3
3(.)P4 50-200/1.5R	6308-2RS1 C3	6306-2RS1 C3		
3(.)P4 50-200/1.5				
3(.)P4 50-200/2.2			6206-2Z C3	6206-2Z C3
3(.)P4 65-125/0.55				
3(.)P4 65-125/0.75	6306-2RS1 C3	6206-2RS1 C3	6204-2Z C3	6204-2Z C3
3(.)P4 65-125/1.1				
3(.)P4 65-160/1.1			6205-2Z C3	6205-2Z C3
3(.)P4 65-160/1.5				
3(.)P4 65-160/2.2	6308-2RS1 C3	6306-2RS1 C3		
3(.)P4 65-200/2.2R			6206-2Z C3	6206-2Z C3
3(.)P4 65-200/2.2				
3(.)P4 65-200/3				
3LP4 65-250/4	6310-2RS1 C3	6308-2RS1 C3	6306-2Z C3	6306-2Z C3
3LP4 65-250/5.5			6208-2Z C3	6208-2Z C3
3LP4 80-160/1.5			6205-2Z C3	6205-2Z C3
3LP4 80-160/2.2R	6308-2RS1 C3	6308-2RS1 C3		
3LP4 80-160/2.2			6206-2Z C3	6206-2Z C3
3LP4 80-200/3				
3LP4 80-200/4R			6306-2Z C3	6306-2Z C3
3LP4 80-200/4	6310-2RS1 C3	6308-2RS1 C3		
3LP4 80-250/5.5R				
3LP4 80-250/5.5			6208-2Z C3	6208-2Z C3
3LP4 80-250/7.5				

**MECHANICAL SEAL (standard, H and E version)**

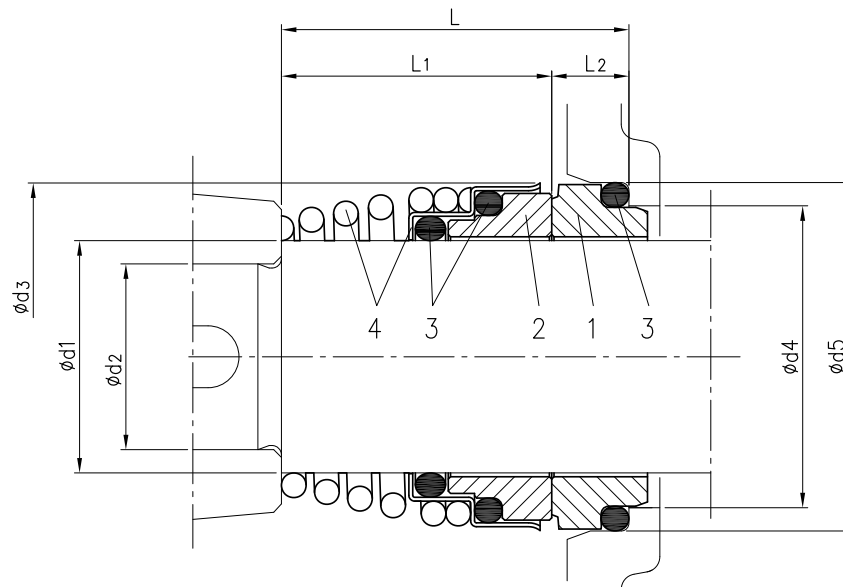

Version	Pump type	Dimensions								Material			
		d1	d2	d3	d4	d5	L	L1	L2	1 Stationary seal ring	2 Rotary seal ring	3 Rubber	4 Frame + spring
Standard	32-125/160/200	22	19	38	31	37	37.5	27.5	10	Carbon	Ceramic	NBR	EN 1.4401 (AISI 316)
	40-125/160/200												
	50-125/160/200												
	65-125/160/200												
H	32-125/160/200	22	19	38	31	37	37.5	27.5	10	Carbon	Ceramic	FPM	EN 1.4401 (AISI 316)
	40-125/160/200												
	50-125/160/200												
	65-125/160/200												
E	80-160	30	24	46	39	45	42.5	32.5	10	Carbon	SiC	EPDM	EN 1.4401 (AISI 316)
	65-250												
E	80-200/250	30	24	46	39	45	42.5	32.5	10	Carbon	SiC	EPDM	EN 1.4401 (AISI 316)
	65-250												

**MECHANICAL SEAL (L version  $\phi 22$ )**

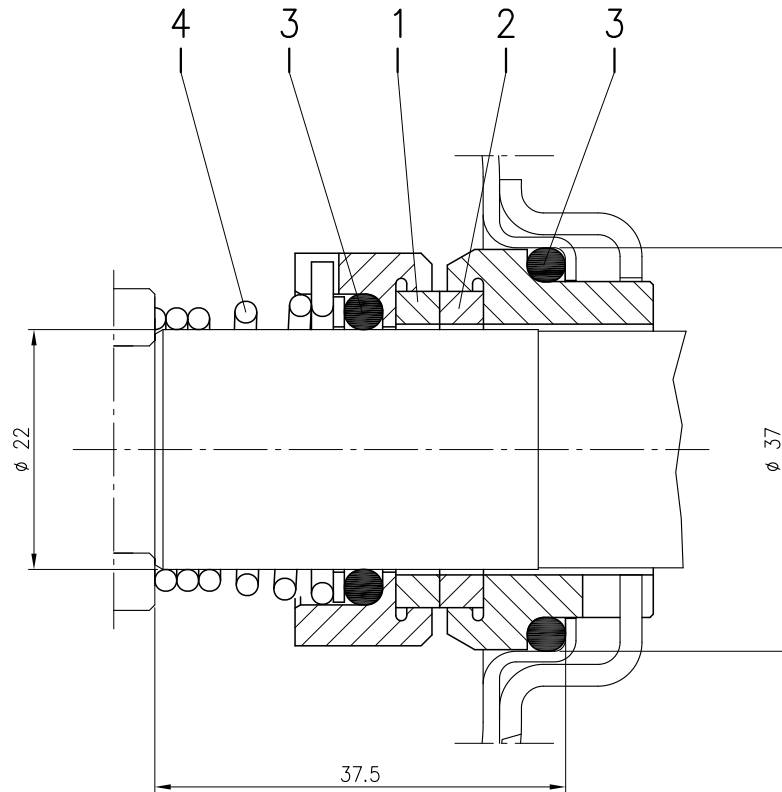

Pump type	Material			
	1 Stationary seal ring	2 Rotary seal ring	3 Rubber	4 Frame + spring
32-125/160/200	SiC	SiC	FPM	EN 1.4571 (AISI 316Ti)
40-125/160/200				
50-125/160/200				
65-125/160/200				
80-160				

**MECHANICAL SEAL (L version ø30)**

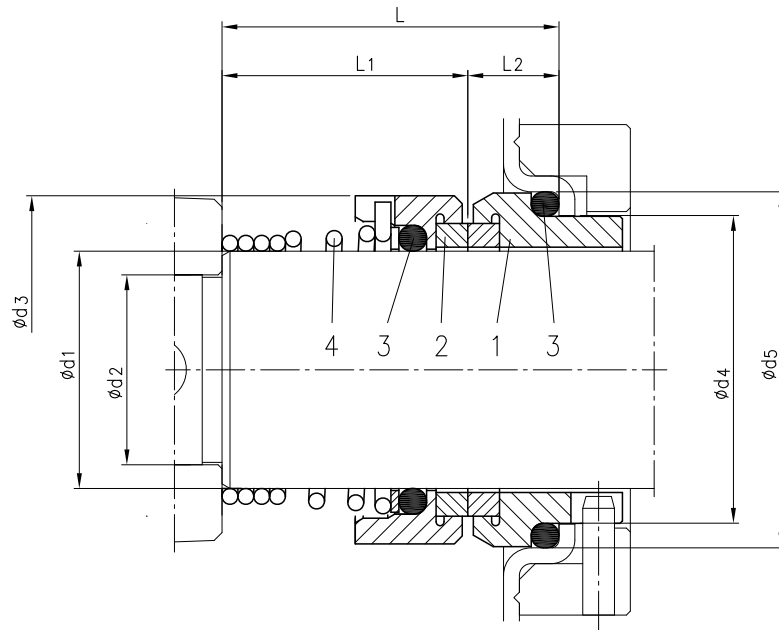

Pump type	Dimensions								Material			
	d1	d2	d3	d4	d5	L	L1	L2	1 Stationary seal ring	2 Rotary seal ring	3 Rubber	4 Frame + spring
65-250 80-200/250	30	24	44	39	45	42.5	31	11.5	SiC	SiC	FPM	EN 1.4571 (AISI 316Ti)

**MECHANICAL SEAL (HS version)**

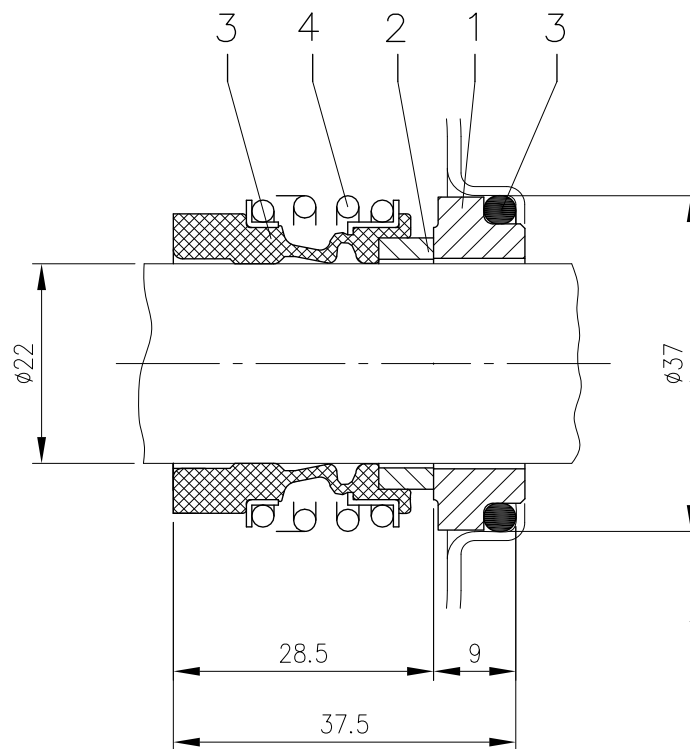

Pump type	Material			
	1 Stationary seal ring	2 Rotary seal ring	3 Rubber	4 Frame + spring
32-125/160/200 40-125/160/200 50-125/160/200 65-125/160/200	SiC	SiC	FPM	EN 1.4571 (AISI 316Ti)

**MECHANICAL SEAL (HW and HSW version)**

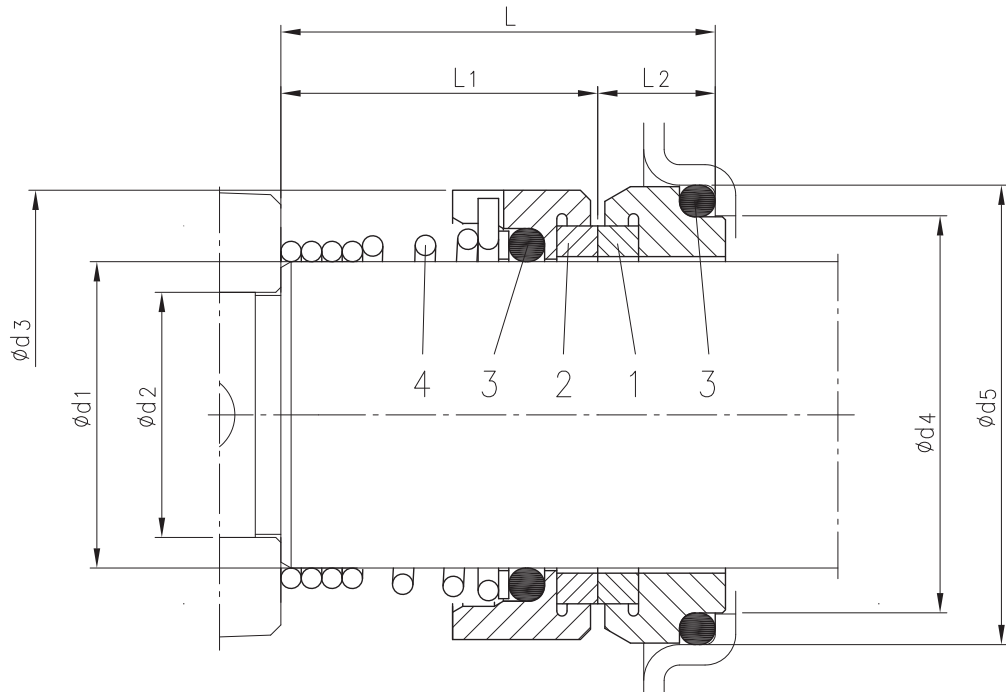

Version	Pump type	Dimensions								Material			
		d1	d2	d3	d4	d5	L	L1	L2	1 Stationary seal ring	2 Rotary seal ring	3 Rubber	4 Frame + spring
HW	32-125/160/200 40-125/160/200 50-125/160/200 65-125/160/200 80-160	22	19	38	31	37	37.5	27.5	10	Tungsten Carbide	Tungsten Carbide	FPM	EN 1.4401 (AISI 316)
	65-250 80-200/250	30	24	46	39	45	42.5	32.5	10				
HSW	32-125/160/200 40-125/160/200 50-125/160/200 65-125/160/200 80-160	22	19	38	31	37	37.5	27.5	10	Tungsten Carbide	SiC	FPM	EN 1.4401 (AISI 316)
	65-250 80-200/250	30	24	46	39	45	42.5	32.5	10				

**FLUID TEMPERATURE RANGE**

The fluid temperature range depends on:

- Material of the elastomers
- Type of fluid pumped
- Material of the sealing faces

for each combination of these parameters the fluid temperature range may be different.

		SEALING FACES MATERIAL			
		CERAMIC-CARBON		ALL (except ceramic-carbon)	
ELASTOMER	NBR	-10 °C	90°C	-10 °C	90°C
	EPDM	-10 °C	90°C	-10 °C	120°C
	FPM	-10 °C	75°C	-10 °C	75°C <sup>1</sup>
		MIN	MAX	MIN	MAX
FLUID TEMPERATURE RANGE					

<sup>1</sup>In case of fluids not containing water, the temperature limit could be increased to 110°C

Therefore, the fluid temperature range is related to the choice of the mechanical seal and its materials.

STANDARD mechanical seal	TEMPERATURE	
	MIN	MAX
STANDARD	-10 °C	90 °C
STANDARD (L VERSION)	-10 °C	75 °C

OPTIONAL mechanical seal	TEMPERATURE	
	MIN	MAX
H	-10 °C	75 °C
HS	-10 °C	75 °C
HW	-10 °C	75 °C
HSW	-10 °C	75 °C
E	-10 °C	120 °C

## COUPLING 3(.)S4

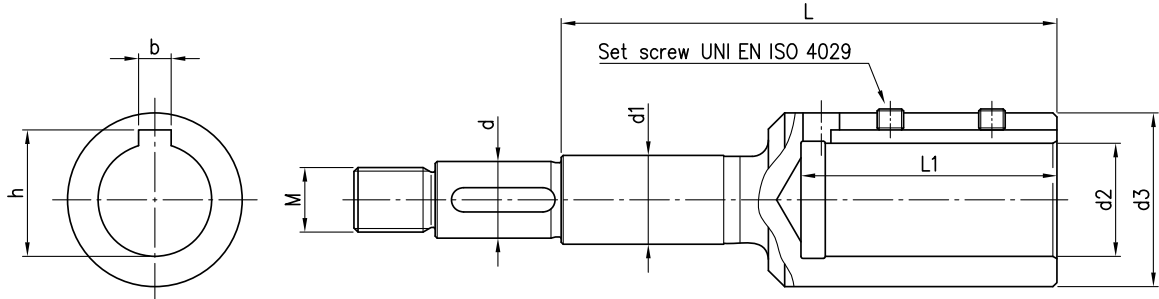

Pump type	[kW]	[HP]	Motor Size	Dimensions mm									
				d	d1	d2	d3	M	L	L1	b	h	Set screw
32-125/0.25	0.25	0.33	71	19	22	14	28	M16x1.5	88	33	5	16.3	M5x6
32-160/0.37R	0.37	0.5	71	19	22	14	28	M16x1.5	88	33	5	16.3	M5x6
32-160/0.37	0.37	0.5	71	19	22	14	28	M16x1.5	88	33	5	16.3	M5x6
32-200/0.55R	0.55	0.75	80	19	22	19	33	M16x1.5	98	43	6	21.8	M6x6
32-200/0.55	0.55	0.75	80	19	22	19	33	M16x1.5	98	43	6	21.8	M6x6
32-200/0.75	0.75	1	80	19	22	19	33	M16x1.5	98	43	6	21.8	M6x6
40-125/0.37R	0.37	0.5	71	19	22	14	28	M16x1.5	88	33	5	16.3	M5x6
40-125/0.37	0.37	0.5	71	19	22	14	28	M16x1.5	88	33	5	16.3	M5x6
40-160/0.55R	0.55	0.75	80	19	22	19	33	M16x1.5	98	43	6	21.8	M6x6
40-160/0.55	0.55	0.75	80	19	22	19	33	M16x1.5	98	43	6	21.8	M6x6
40-200/1.1R	1.1	1.5	90	19	22	24	39	M16x1.5	110	53	8	27.3	M8x8
40-200/1.1	1.1	1.5	90	19	22	24	39	M16x1.5	110	53	8	27.3	M8x8
40-200/1.5	1.5	2	90	19	22	24	39	M16x1.5	110	53	8	27.3	M8x8
50-125/0.55R	0.55	0.75	80	19	22	19	33	M16x1.5	98	43	6	21.8	M6x6
50-125/0.55	0.55	0.75	80	19	22	19	33	M16x1.5	98	43	6	21.8	M6x6
50-160/1.1R	1.1	1.5	90	19	22	24	39	M16x1.5	110	53	8	27.3	M8x8
50-160/1.1	1.1	1.5	90	19	22	24	39	M16x1.5	110	53	8	27.3	M8x8
50-200/1.5R	1.5	2	90	19	22	24	39	M16x1.5	110	53	8	27.3	M8x8
50-200/1.5	1.5	2	90	19	22	24	39	M16x1.5	110	53	8	27.3	M8x8
50-200/2.2	2.2	3	100	22	22	28	43	M18x1.5	153	63	8	31.3	M8x8
65-125/0.55	0.55	0.75	80	19	22	19	33	M16x1.5	98	43	6	21.8	M6x6
65-125/0.75	0.75	1	80	19	22	19	33	M16x1.5	98	43	6	21.8	M6x6
65-125/1.1	1.1	1.5	90	19	22	24	39	M16x1.5	110	53	8	27.3	M8x8
65-160/1.1	1.1	1.5	90	19	22	24	39	M16x1.5	110	53	8	27.3	M8x8
65-160/1.5	1.5	2	90	19	22	24	39	M16x1.5	110	53	8	27.3	M8x8
65-160/2.2	2.2	3	100	19	22	28	43	M16x1.5	122	63	8	31.3	M8x8
65-200/2.2R	2.2	3	100	19	22	28	43	M16x1.5	122	63	8	31.3	M8x8
65-200/2.2	2.2	3	100	19	22	28	43	M16x1.5	122	63	8	31.3	M8x8
65-200/3	3	4	100	19	22	28	43	M16x1.5	122	63	8	31.3	M8x8
65-250/4	4	5.5	112	24	30	28	43	M20x1.5	128	63	8	31.3	M8x8
65-250/5.5	5.5	7.5	132	24	30	38	58	M20x1.5	151	84	10	41.3	M8x8
80-160/1.5	1.5	2	90	19	22	24	39	M16x1.5	110	53	8	27.3	M8x8
80-160/2.2R	2.2	3	100	19	22	28	43	M16x1.5	122	63	8	31.3	M8x8
80-160/2.2	2.2	3	100	19	22	28	43	M16x1.5	122	63	8	31.3	M8x8
80-200/3	3	4	100	24	30	28	43	M20x1.5	128	63	8	31.3	M8x8
80-200/4R	4	5.5	112	24	30	28	43	M20x1.5	128	63	8	31.3	M8x8
80-200/4	4	5.5	112	24	30	28	43	M20x1.5	128	63	8	31.3	M8x8
80-250/5.5R	5.5	7.5	132	24	30	38	58	M20x1.5	151	84	10	41.3	M8x8
80-250/5.5	5.5	7.5	132	24	30	38	58	M20x1.5	151	84	10	41.3	M8x8
80-250/7.5	7.5	10	132	24	30	38	58	M20x1.5	151	84	10	41.3	M8x8



### FLEXIBLE COUPLING 3(.)P4

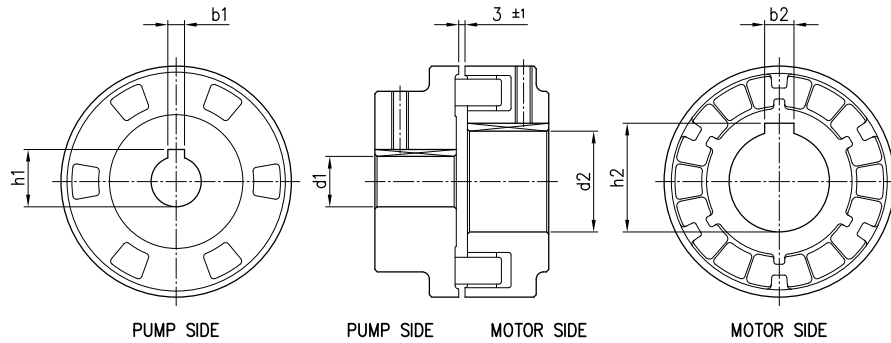

Pump type	[kW]	[HP]	Motor Size	Dimensions mm					
				d1	b1	h1	d2	b2	h2
32-125/0.25	0.25	0.33	71	24	8	27.3	14	5	16.3
32-160/0.37R	0.37	0.5	71	24	8	27.3	14	5	16.3
32-160/0.37	0.37	0.5	71	24	8	27.3	14	5	16.3
32-200/0.55R	0.55	0.75	80	24	8	27.3	19	6	21.8
32-200/0.55	0.55	0.75	80	24	8	27.3	19	6	21.8
32-200/0.75	0.75	1	80	24	8	27.3	19	6	21.8
40-125/0.37R	0.37	0.5	71	24	8	27.3	14	5	16.3
40-125/0.37	0.37	0.5	71	24	8	27.3	14	5	16.3
40-160/0.55R	0.55	0.75	80	24	8	27.3	19	6	21.8
40-160/0.55	0.55	0.75	80	24	8	27.3	19	6	21.8
40-200/1.1R	1.1	1.5	90	24	8	27.3	24	8	27.3
40-200/1.1	1.1	1.5	90	24	8	27.3	24	8	27.3
40-200/1.5	1.5	2	90	24	8	27.3	24	8	27.3
50-125/0.55R	0.55	0.75	80	24	8	27.3	19	6	21.8
50-125/0.55	0.55	0.75	80	24	8	27.3	19	6	21.8
50-160/1.1R	1.1	1.5	90	24	8	27.3	24	8	27.3
50-160/1.1	1.1	1.5	90	24	8	27.3	24	8	27.3
50-200/1.5R	1.5	2	90	24	8	27.3	24	8	27.3
50-200/1.5	1.5	2	90	24	8	27.3	24	8	27.3
50-200/2.2	2.2	3	100	24	8	27.3	28	8	31.3
65-125/0.55	0.55	0.75	80	24	8	27.3	19	6	21.8
65-125/0.75	0.75	1	80	24	8	27.3	19	6	21.8
65-125/1.1	1.1	1.5	90	24	8	27.3	24	8	27.3
65-160/1.1	1.1	1.5	90	24	8	27.3	24	8	27.3
65-160/1.5	1.5	2	90	24	8	27.3	24	8	27.3
65-160/2.2	2.2	3	100	24	8	27.3	28	8	31.3
65-200/2.2R	2.2	3	100	24	8	27.3	28	8	31.3
65-200/2.2	2.2	3	100	24	8	27.3	28	8	31.3
65-200/3	3	4	100	24	8	27.3	28	8	31.3
65-250/4	4	5.5	112	32	10	35.3	28	8	31.3
65-250/5.5	5.5	7.5	132	32	10	35.3	38	10	41.3
80-160/1.5	1.5	2	90	24	8	27.3	24	8	27.3
80-160/2.2R	2.2	3	100	24	8	27.3	28	8	31.3
80-160/2.2	2.2	3	100	24	8	27.3	28	8	31.3
80-200/3	3	4	100	32	10	35.3	28	8	31.3
80-200/4R	4	5.5	112	32	10	35.3	28	8	31.3
80-200/4	4	5.5	112	32	10	35.3	28	8	31.3
80-250/5.5R	5.5	7.5	132	32	10	35.3	38	10	41.3
80-250/5.5	5.5	7.5	132	32	10	35.3	38	10	41.3
80-250/7.5	7.5	10	132	32	10	35.3	38	10	41.3

## FITTINGS

### COUNTERFLANGE ZINCKED STEEL

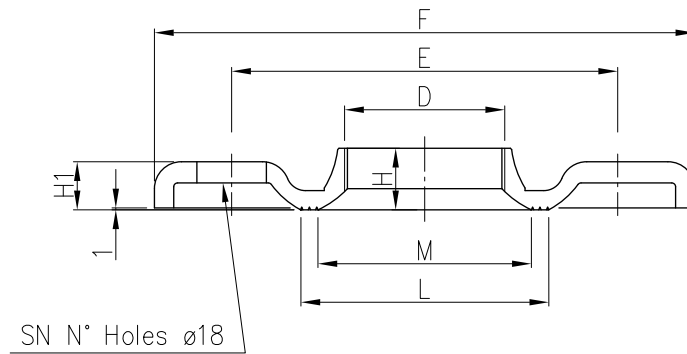

DN	Counterflange								Screw	
	D	E	F	H	H1	L	M	SN	DIMENSIONS	MATERIAL
32	G 1 1/4	100	140	15	11.5	67	50	4	M16x55	Gv. Steel 8.8 strenght class ISO 898-1
40	G 1 1/2	110	150	17.5	11.5	72	58	4		
50	G2	125	165	19	15	89	70	4		
65	G 2 1/2	145	185	23	14	104	88	4		
80	G3	160	200	24	16	117.5	100	8	M16x60	
100	G4	180	220	29	16	144	125	8		

### COUNTERFLANGE EN 1.4404 (AISI 316L)

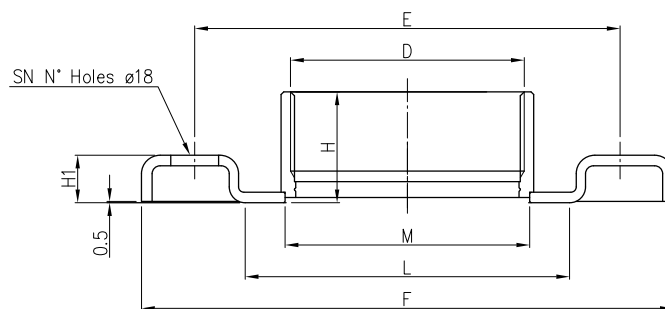

DN	Counterflange								Screw	
	D	E	F	H	H1	L	M	SN	DIMENSIONS	MATERIAL
32	G 1 1/4	100	140	29.5	14	66	44	4	M16x55	A2-70 class ISO 3506-1
40	G 1 1/2	110	150	29.5	14	71	50.5			
50	G 2	125	165	34	16	83	63			
65	G 2 1/2	145	185	40	16	103	80	8	M16x60	
80	G3	160	200	42	18	122	92			

**COUNTERFLANGE EN 1.4404 (AISI 316L) DN100**

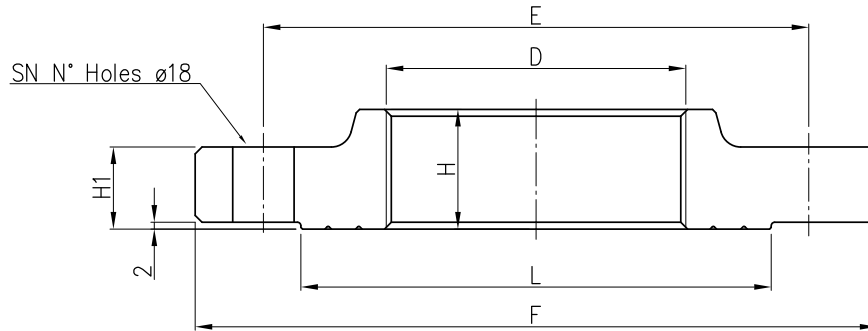

DN	D	Counterflange				SN	Screw		
		E	F	H	H1		DIMENSIONS	MATERIAL	
100	G4	180	220	35	20	150	8	M16x70	A2-70 class ISO 3506-1

**GASKET**

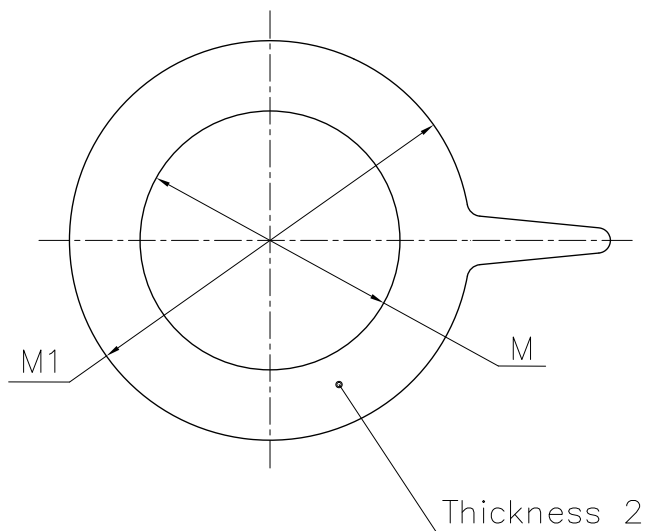

DN	M	M1
32	38	82
40	50	93
50	60	107
65	80	125
80	90	140
100	115	160

Material : EPDM for standard version  
FPM for L version

## PUMP 3(.)M4 32, 40, 50, 65-125/160/200

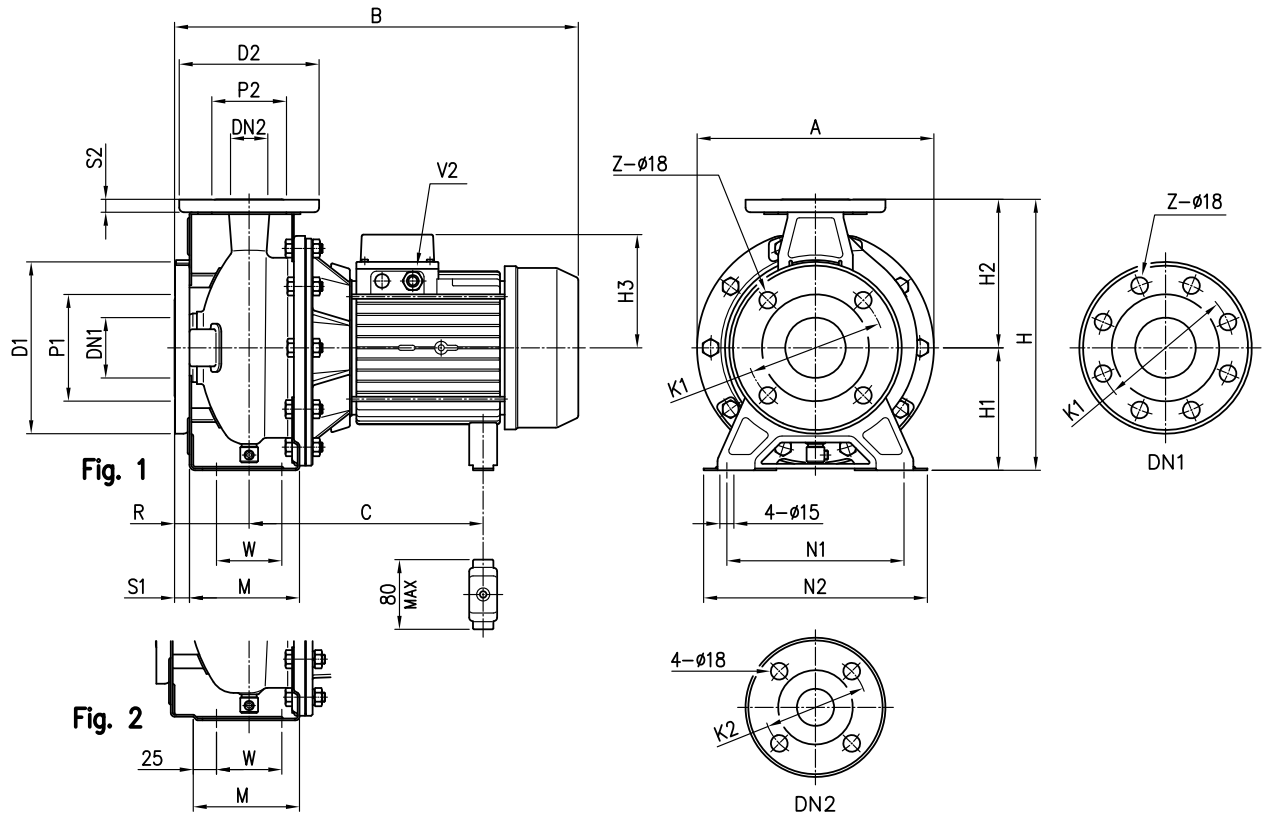

Pump type	Dimensions (mm)																				Weight [kgf]						
	∅ DN1	∅ P1	∅ K1	∅ D1	S1	Z	[1]	[2]	∅ DN2	∅ P2	∅ K2	∅ D2	S2	Fig.	H	H1	H2	H3	R	W		M	N1	N2	A	B	C
32-125/0.25	50	95	125	165	16	4	-	32	75	100	140	14	1	252	112	140	102	80	70	114	140	190	213	371	205	PG 11	16.2
32-160/0.37R	50	95	125	165	16	4	-	32	75	100	140	14	1	292	132	160	119	80	70	118	190	240	254	393	219	PG 11	22
32-200/0.37	50	95	125	165	16	4	-	32	75	100	140	14	1	292	132	160	119	80	70	118	190	240	254	393	219	PG 11	22.2
32-200/0.55R	50	95	125	165	16	4	-	32	75	100	140	14	1	340	160	180	119	80	70	119	190	240	296	393	219	PG 11	26.8
32-200/0.55	50	95	125	165	16	4	-	32	75	100	140	14	1	340	160	180	119	80	70	119	190	240	296	393	219	PG 11	26.8
32-200/0.75	50	95	125	165	16	4	-	32	75	100	140	14	1	340	160	180	124	80	70	119	190	240	296	432	244+255	PG 13.5	28.1
40-125/0.37R	65	115	145	185	16	4	-	40	80	110	150	14	1	252	112	140	102	80	70	114	160	210	213	371	205	PG 11	16.8
40-125/0.37	65	115	145	185	16	4	-	40	80	110	150	14	1	252	112	140	102	80	70	114	160	210	213	371	205	PG 11	16.9
40-160/0.55R	65	115	145	185	16	4	-	40	80	110	150	14	1	292	132	160	119	80	70	118	190	240	254	393	219	PG 11	22.5
40-160/0.55	65	115	145	185	16	4	-	40	80	110	150	14	1	292	132	160	119	80	70	118	190	240	254	393	219	PG 11	22.9
40-200/1.1R	65	115	145	185	16	4	-	40	80	110	150	14	2	340	160	180	124	100	70	115	212	265	296	452	244+255	PG 13.5	28.5
40-200/1.1	65	115	145	185	16	4	-	40	80	110	150	14	2	340	160	180	124	100	70	115	212	265	296	452	244+255	PG 13.5	28.6
40-200/1.5	65	115	145	185	16	4	-	40	80	110	150	14	2	340	160	180	124	100	70	115	212	265	296	491	244+255	PG 13.5	30.3
50-125/0.55R	65	115	145	185	16	4	-	50	95	125	165	16	2	292	132	160	119	100	70	114	190	240	254	413	219	PG 11	22.8
50-125/0.55	65	115	145	185	16	4	-	50	95	125	165	16	2	292	132	160	119	100	70	114	190	240	254	413	219	PG 11	22.8
50-160/1.1R	65	115	145	185	16	4	-	50	95	125	165	16	2	340	160	180	124	100	70	115	212	265	296	452	244+255	PG 13.5	28.6
50-160/1.1	65	115	145	185	16	4	-	50	95	125	165	16	2	340	160	180	124	100	70	115	212	265	296	452	244+255	PG 13.5	28.7
50-200/1.5R	65	115	145	185	16	4	-	50	95	125	165	16	2	360	160	200	124	100	70	115	212	265	296	491	244+255	PG 13.5	30.5
50-200/1.5	65	115	145	185	16	4	-	50	95	125	165	16	2	360	160	200	124	100	70	115	212	265	296	491	244+255	PG 13.5	31.6
50-200/2.2	65	115	145	185	16	4	-	50	95	125	165	16	2	360	160	200	141	100	70	115	212	265	296	474	253	PG 16	30
65-125/0.55	80	134	160	200	18	8	4	65	115	145	185	16	2	340	160	180	119	100	95	140	212	280	254	413	219	PG 11	23.2
65-125/0.75	80	134	160	200	18	8	4	65	115	145	185	16	2	340	160	180	124	100	95	140	212	280	254	452	244+255	PG 13.5	20
65-125/1.1	80	134	160	200	18	8	4	65	115	145	185	16	2	340	160	180	124	100	95	140	212	280	254	452	244+255	PG 13.5	20
65-160/1.1	80	134	160	200	18	8	4	65	115	145	185	16	2	360	160	200	124	100	95	140	212	280	296	452	244+255	PG 13.5	28.5
65-160/1.5	80	134	160	200	18	8	4	65	115	145	185	16	2	360	160	200	124	100	95	140	212	280	296	491	244+255	PG 13.5	30
65-160/2.2	80	134	160	200	18	8	4	65	115	145	185	16	2	360	160	200	141	100	95	140	212	280	296	474	253	PG 16	32
65-200/2.2R	80	134	160	200	18	8	4	65	115	145	185	16	2	405	180	225	141	100	95	140	250	320	296	474	253	PG 16	30
65-200/2.2	80	134	160	200	18	8	4	65	115	145	185	16	2	405	180	225	141	100	95	140	250	320	296	474	253	PG 16	30
65-200/3	80	134	160	200	18	8	4	65	115	145	185	16	2	405	180	225	141	100	95	140	250	320	296	514	253	PG 16	38

[1] Standard [2] On request

**PUMP 3(.)M4 65-250, 80-160/200, 80-250/5.5**

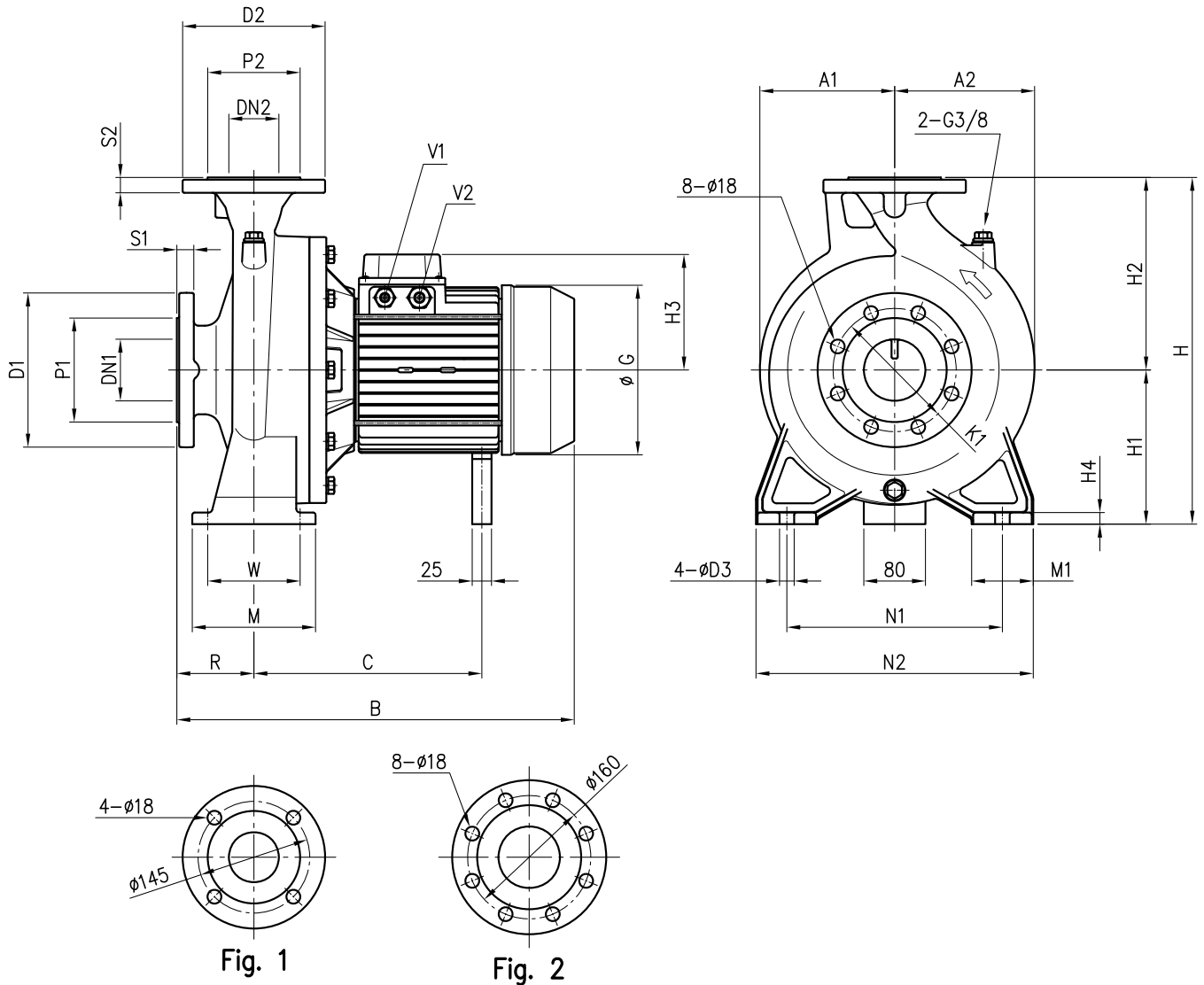

Pump type	Dimensions [mm]																							Weight [kgf]					
	DN1	P1	K1	D1	S1	DN2	P2	D2	S2	H	H1	H2	H3	H4	R	W	N1	N2	M	M1	A1	A2	B		C	G	D3	V1	V2
65-250/4	80	135	160	200	22	65 Fig. 1	120	185	20	450	200	250	150	15	100	120	280	360	160	80	175	182	559	295	220	19	PG13.5	PG16	81
65-250/5.5	80	135	160	200	22	65 Fig. 1	120	185	20	450	200	250	178	15	100	120	280	360	160	80	175	182	612	376	259	19	PG13.5	PG21	96
80-160/1.5	100	155	180	225	24	80 Fig. 2	135	200	22	405	180	225	124	13	125	95	250	320	125	65	147	173	516	244+255	176	15	-	PG13.5	53
80-160/2.2R	100	155	180	225	24	80 Fig. 2	135	200	22	405	180	225	141	13	125	95	250	320	125	65	147	173	499	253	193	15	-	PG16	53
80-160/2.2	100	155	180	225	24	80 Fig. 2	135	200	22	405	180	225	141	13	125	95	250	320	125	65	147	173	499	253	193	15	-	PG16	53
80-200/3	100	155	180	225	24	80 Fig. 2	135	200	22	430	180	250	141	13	125	95	280	345	125	65	175	182	561	275	193	15	-	PG16	73
80-200/4R	100	155	180	225	24	80 Fig. 2	135	200	22	430	180	250	150	13	125	95	280	345	125	65	175	182	584	295	220	15	PG13.5	PG16	80
80-200/4	100	155	180	225	24	80 Fig. 2	135	200	22	430	180	250	150	13	125	95	280	345	125	65	175	182	584	295	220	15	PG13.5	PG16	81
80-250/5.5R	100	155	180	225	24	80 Fig. 2	135	200	22	480	200	280	178	15	125	120	315	400	160	80	175	192	637	376	259	19	PG13.5	PG21	94
80-250/5.5	100	155	180	225	24	80 Fig. 2	135	200	22	480	200	280	178	15	125	120	315	400	160	80	175	192	637	376	259	19	PG13.5	PG21	95

PUMP 3(.)M4 80-250/7.5

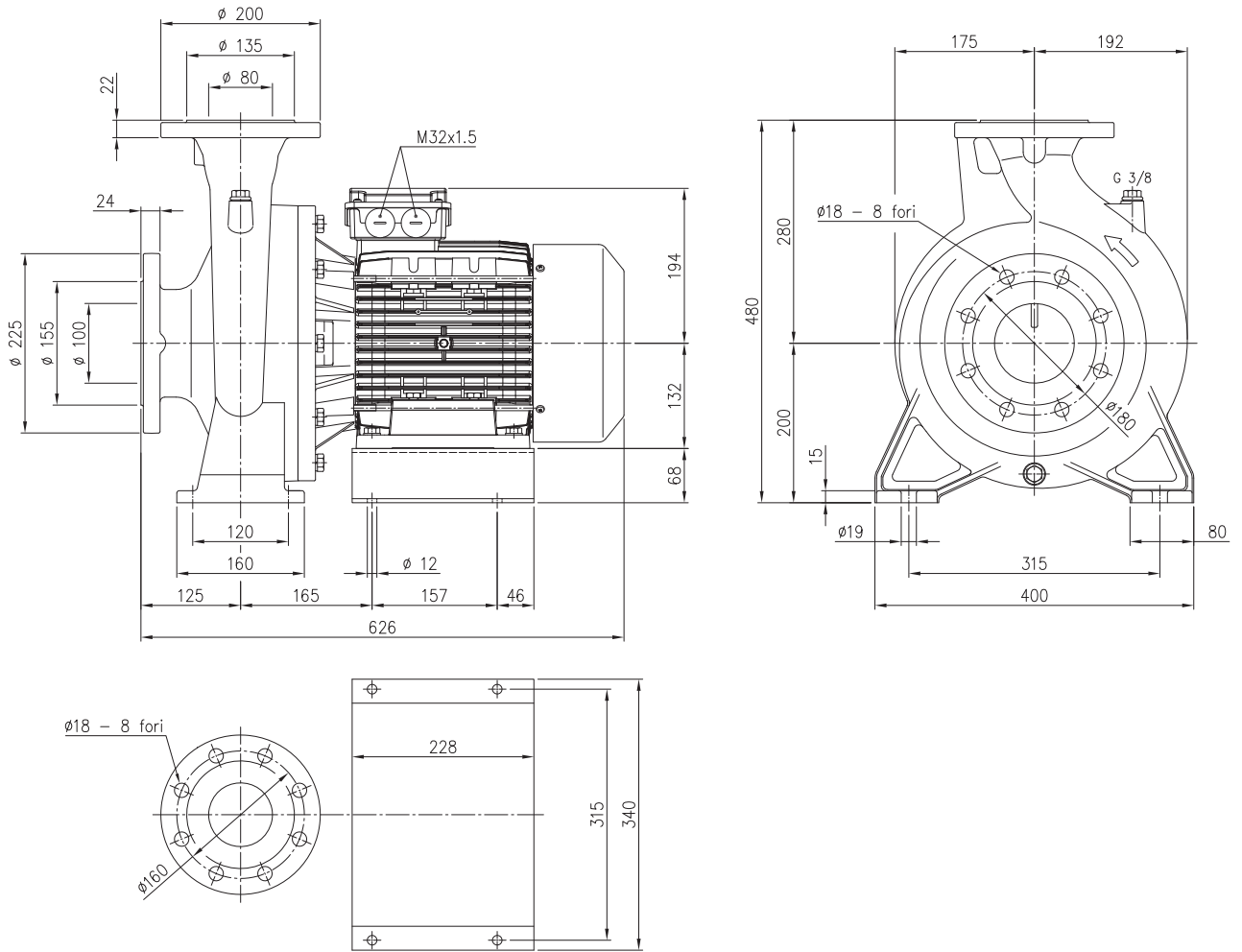

Weight: 119 kgf

**PUMP 3(.)S4 32, 40, 50, 65-125/160**

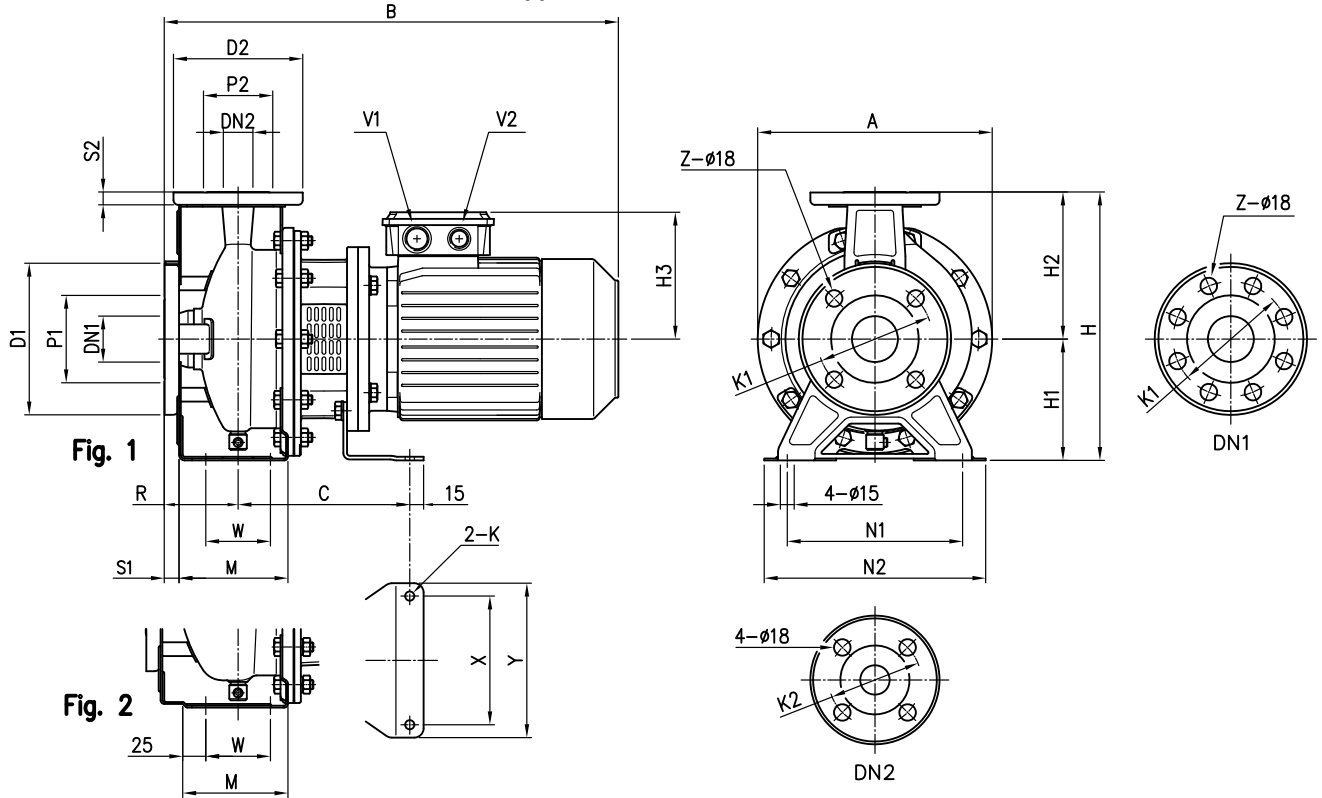

Pump type	Dimensions (mm)																												Weight [ kgf ]		
	Ø DN1	Ø P1	Ø K1	Ø D1	S1	[1]	[2]	Ø DN2	Ø P2	Ø K2	Ø D2	S2	Fig.	H	H1	H2	H3	R	W	M	N1	N2	A	B	C	X	Y	K		V1	V2
32-125/0.25	50	95	125	165	16	4	-	32	75	100	140	14	1	252	112	140	114	80	70	114	140	190	213	404	153	112	140	8	M20x1.5	M16x1.5	15.4
32-160/0.37R	50	95	125	165	16	4	-	32	75	100	140	14	1	292	132	160	114	80	70	118	190	240	254	404	153	112	140	8	M20x1.5	M16x1.5	18.5
32-160/0.37	50	95	125	165	16	4	-	32	75	100	140	14	1	292	132	160	114	80	70	118	190	240	254	404	153	112	140	8	M20x1.5	M16x1.5	18.7
32-200/0.55R	50	95	125	165	16	4	-	32	75	100	140	14	1	340	160	180	139	80	70	119	190	240	296	430	174	140	168	10	M25x1.5	M20x1.5	33
32-200/0.55	50	95	125	165	16	4	-	32	75	100	140	14	1	340	160	180	139	80	70	119	190	240	296	430	174	140	168	10	M25x1.5	M20x1.5	33
32-200/0.75	50	95	125	165	16	4	-	32	75	100	140	14	1	340	160	180	139	80	70	119	190	240	296	430	174	140	168	10	M25x1.5	M20x1.5	29.5
40-125/0.37R	65	115	145	185	16	4	-	40	80	110	150	14	1	252	112	140	114	80	70	114	160	210	213	404	153	112	140	8	M20x1.5	M16x1.5	16.2
40-125/0.37	65	115	145	185	16	4	-	40	80	110	150	14	1	252	112	140	114	80	70	114	160	210	213	404	153	112	140	8	M20x1.5	M16x1.5	16.2
40-160/0.55R	65	115	145	185	16	4	-	40	80	110	150	14	1	292	132	160	139	80	70	118	190	240	254	430	174	140	168	10	M25x1.5	M20x1.5	23.5
40-160/0.55	65	115	145	185	16	4	-	40	80	110	150	14	1	292	132	160	139	80	70	118	190	240	254	430	174	140	168	10	M25x1.5	M20x1.5	23.5
40-200/1.1R	65	115	145	185	16	4	-	40	80	110	150	14	2	340	160	180	148	100	70	115	212	265	296	497	186	140	168	10	M25x1.5	M20x1.5	32.1
40-200/1.1	65	115	145	185	16	4	-	40	80	110	150	14	2	340	160	180	148	100	70	115	212	265	296	497	186	140	168	10	M25x1.5	M20x1.5	32.1
40-200/1.5	65	115	145	185	16	4	-	40	80	110	150	14	2	340	160	180	148	100	70	115	212	265	296	497	186	140	168	10	M25x1.5	M20x1.5	32.9
50-125/0.55R	65	115	145	185	16	4	-	50	95	125	165	16	2	292	132	160	139	100	70	114	190	240	254	450	174	140	168	10	M25x1.5	M20x1.5	23.7
50-125/0.55	65	115	145	185	16	4	-	50	95	125	165	16	2	292	132	160	139	100	70	114	190	240	254	450	174	140	168	10	M25x1.5	M20x1.5	23.7
50-160/1.1R	65	115	145	185	16	4	-	50	95	125	165	16	2	340	160	180	148	100	70	115	212	265	296	497	186	140	168	10	M25x1.5	M20x1.5	31.8
50-160/1.1	65	115	145	185	16	4	-	50	95	125	165	16	2	340	160	180	148	100	70	115	212	265	296	497	186	140	168	10	M25x1.5	M20x1.5	31.8
50-200/1.5R	65	115	145	185	16	4	-	50	95	125	165	16	2	360	160	200	148	100	70	115	212	265	296	497	186	140	168	10	M25x1.5	M20x1.5	34.5
50-200/1.5	65	115	145	185	16	4	-	50	95	125	165	16	2	360	160	200	148	100	70	115	212	265	296	497	186	140	168	10	M25x1.5	M20x1.5	34.5
65-125/0.55	80	134	160	200	18	8	4	65	115	145	185	16	2	340	160	180	139	100	95	140	212	280	254	450	174	140	168	10	M25x1.5	M20x1.5	21.5
65-125/0.75	80	134	160	200	18	8	4	65	115	145	185	16	2	340	160	180	139	100	95	140	212	280	254	450	174	140	168	10	M25x1.5	M20x1.5	30
65-125/1.1	80	134	160	200	18	8	4	65	115	145	185	16	2	340	160	180	148	100	95	140	212	280	254	497	186	140	168	10	M25x1.5	M20x1.5	27.8
65-160/1.1	80	134	160	200	18	8	4	65	115	145	185	16	2	360	160	200	148	100	95	140	212	280	296	497	186	140	168	10	M25x1.5	M20x1.5	28.8
65-160/1.5	80	134	160	200	18	8	4	65	115	145	185	16	2	360	160	200	148	100	95	140	212	280	296	497	186	140	168	10	M25x1.5	M20x1.5	40.4

**PUMP 3(.)S4 50, 65-160/200**

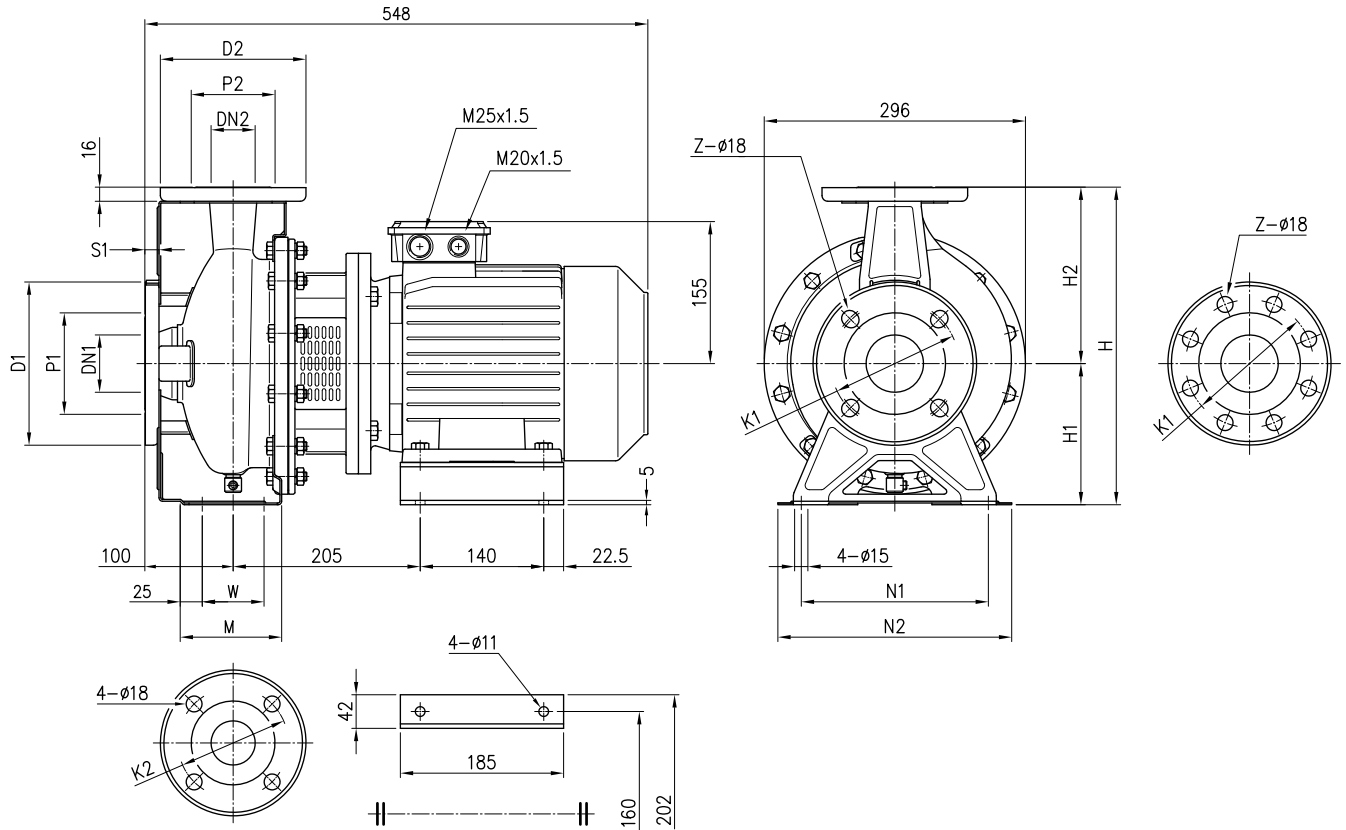

Pump type	Dimensions (mm)																		Weight [kgf]
	∅ DN1	∅ P1	∅ K1	∅ D1	S1	Z [1]	Z [2]	∅ DN2	∅ P2	∅ K2	∅ D2	H	H1	H2	W	M	N1	N2	
3S 50-200/2.2	65	115	145	185	16	4	-	50	95	125	165	360	160	200	70	115	212	265	43.4
3S 65-160/2.2	80	134	160	200	18	8	4	65	115	145	185	360	160	200	95	140	212	280	46.4
3S 65-200/2.2R	80	134	160	200	18	8	4	65	115	145	185	405	180	225	95	140	250	320	42.9
3S 65-200/2.2	80	134	160	200	18	8	4	65	115	145	185	405	180	225	95	140	250	320	43.4
3S 65-200/3	80	134	160	200	18	8	4	65	115	145	185	405	180	225	95	140	250	320	48.5



PUMP 3LS4 65-250, 80-160/200/250

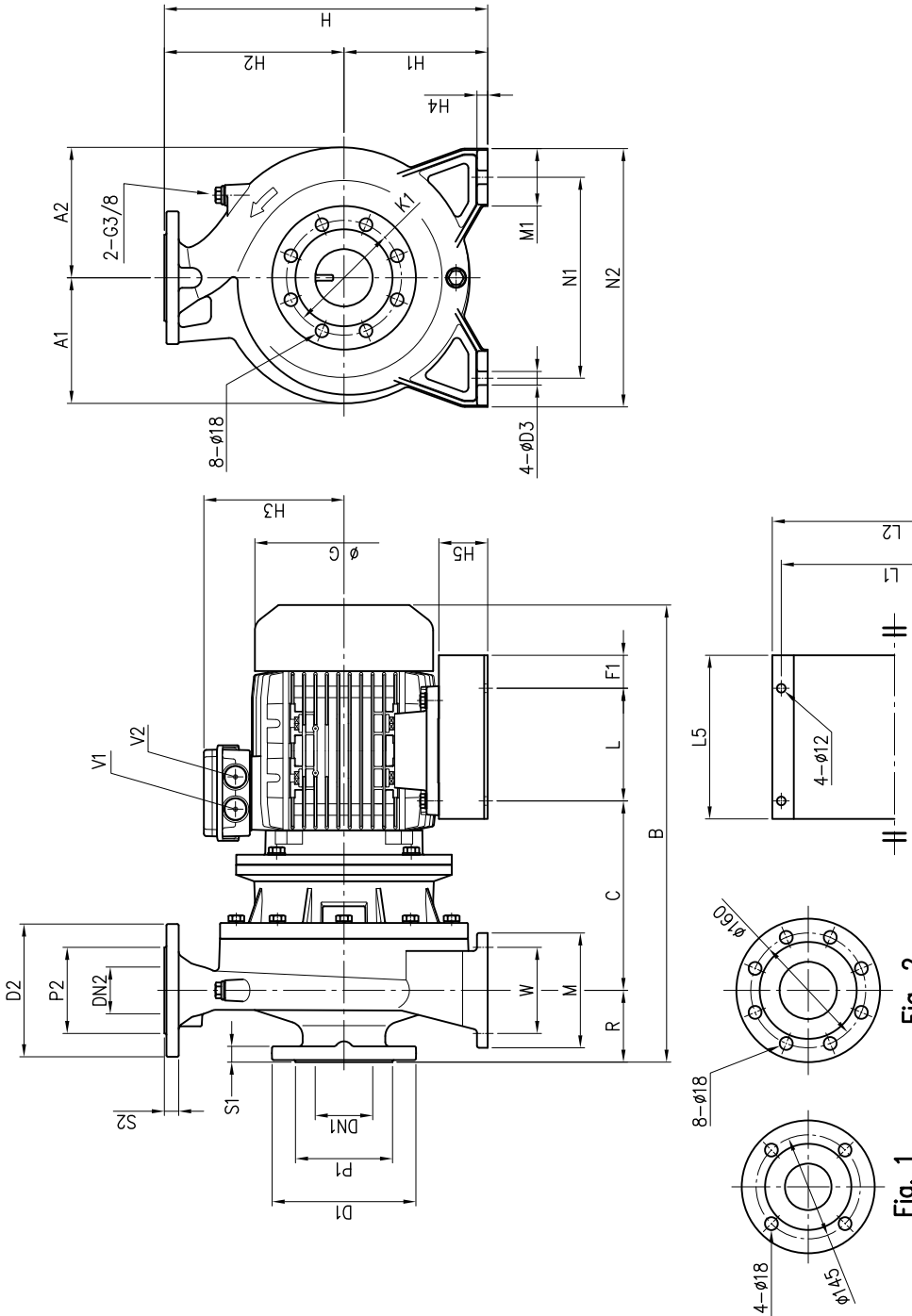

Pump type	Dimensions [mm]																												Weight [kgf]						
	DN1	P1	K1	D1	S1	DN2	P2	D2	S2	H	H1	H2	H3	H4	H5	R	W	N1	N2	M	M1	L	L1	L2	L3	L4	L5	A1		A2	B	C	F1	G	D3
65-250/4	80	135	160	200	22	65 Fig. 1	120	185	20	450	200	250	171	15	88	100	120	280	360	160	80	147	265	290	187	175	182	580	215	20	225	19	M25x1.5	M20x1.5	90.6
65-250/5.5	80	135	160	200	22	65 Fig. 1	120	185	20	450	200	250	198	15	68	100	120	280	360	160	80	157	315	340	228	175	182	637	264	46	248	19	M32x1.5	M32x1.5	118
80-160/2.2R	100	155	180	225	24	80 Fig. 2	135	200	22	405	180	225	155	13	80	125	95	250	320	125	65	140	250	275	190	147	173	573	205	25	196	15	M25x1.5	M20x1.5	70.1
80-160/2.2	100	155	180	225	24	80 Fig. 2	135	200	22	405	180	225	155	13	80	125	95	250	320	125	65	140	250	275	190	147	173	573	205	25	196	15	M25x1.5	M20x1.5	70.4
80-200/3	100	155	180	225	24	80 Fig. 2	135	200	22	430	180	250	155	13	80	125	95	280	345	125	65	140	250	275	190	175	182	583	215	25	196	15	M25x1.5	M20x1.5	80
80-200/4R	100	155	180	225	24	80 Fig. 2	135	200	22	430	180	250	161	13	68	125	95	280	345	125	65	157	315	340	228	175	182	605	198	46	225	15	M25x1.5	M20x1.5	89.6
80-200/4	100	155	180	225	24	80 Fig. 2	135	200	22	430	180	250	161	13	68	125	95	280	345	125	65	157	315	340	228	175	182	605	198	46	225	15	M25x1.5	M20x1.5	95.6
80-250/5.5R	100	155	180	225	24	80 Fig. 2	135	200	22	480	200	280	198	15	68	125	120	315	400	160	80	157	315	340	228	175	192	662	264	46	248	19	M32x1.5	M32x1.5	124
80-250/5.5	100	155	180	225	24	80 Fig. 2	135	200	22	480	200	280	198	15	68	125	120	315	400	160	80	157	315	340	228	175	192	662	264	46	248	19	M32x1.5	M32x1.5	125
80-250/7.5	100	155	180	225	24	80 Fig. 2	135	200	22	480	200	280	198	15	68	125	120	315	400	160	80	157	315	340	228	175	192	722	264	46	248	19	M32x1.5	M32x1.5	134

[1] Standard [2] On request

**PUMP 3LS4 80-160/1.5**

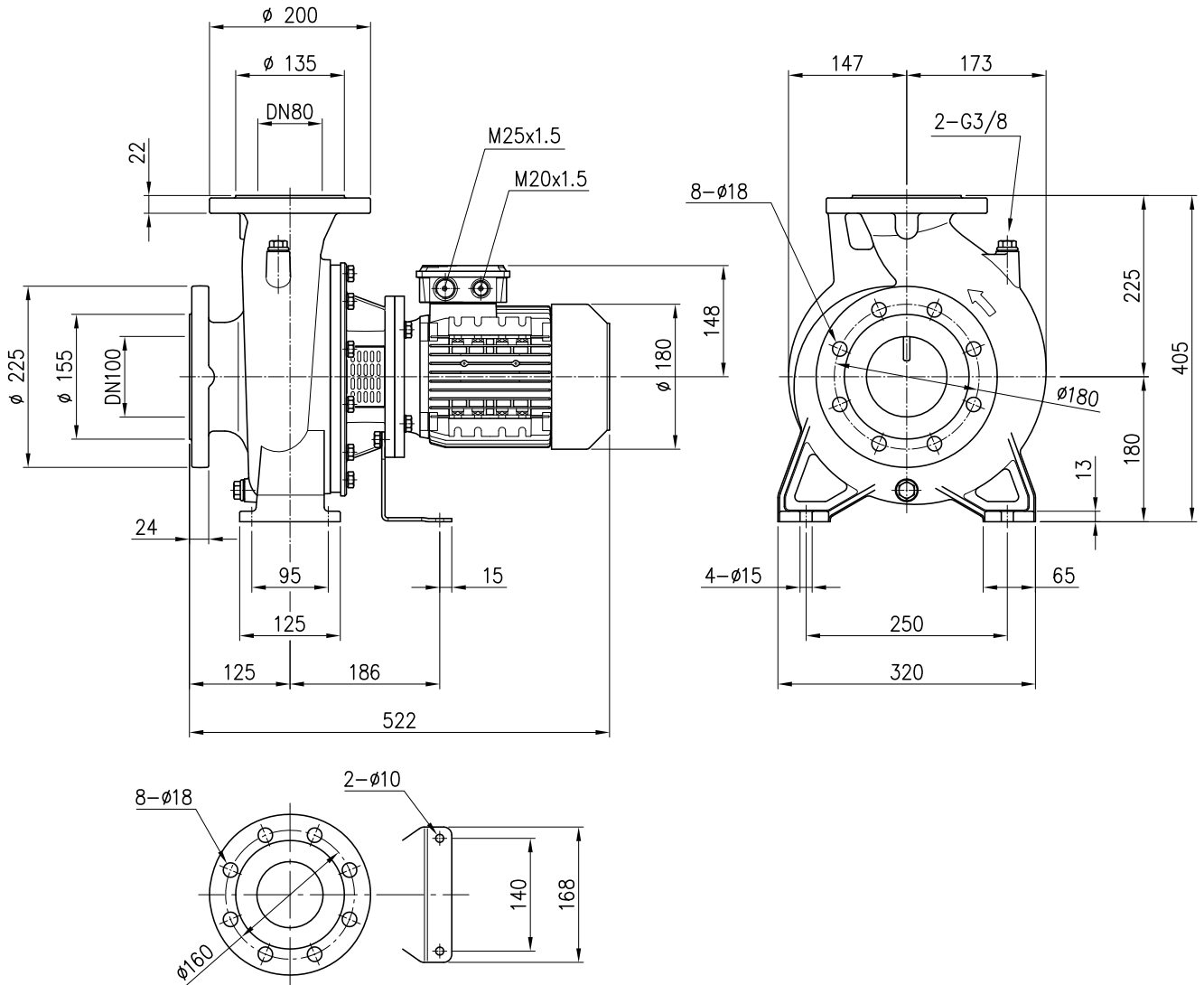

Weight: 58 kgf

PUMP 3(.)P4 32, 40, 50, 65-125/160/200

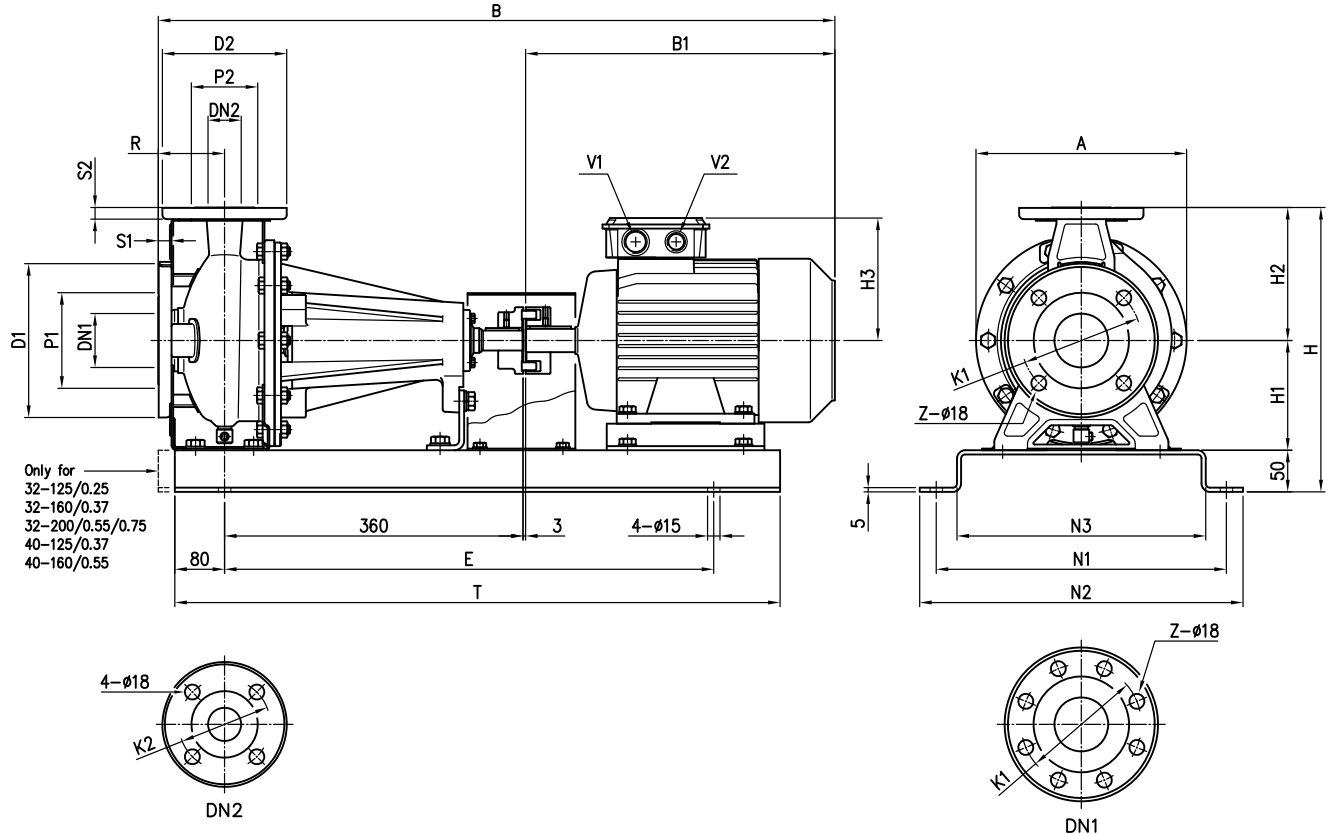

Pump type	Dimensions [mm]																				Weight [kgf]							
	Ø DN1	Ø P1	Ø K1	Ø D1	S1	Z [1] [2]	Ø DN2	Ø P2	Ø K2	Ø D2	S2	H	H1	H2	H3	R	A	B	B1	E		N1	N2	N3	T	V1	V2	
3P 32-125/0.25	50	95	125	165	16	4	-	32	75	100	140	14	302	112	140	114	80	213	689	246	550	300	340	250	710	M20x1.5	M16x1.5	37
3P 32-160/0.37R	50	95	125	165	16	4	-	32	75	100	140	14	342	132	160	114	80	254	689	246	510	350	390	300	670	M20x1.5	M16x1.5	41
3P 32-160/0.37	50	95	125	165	16	4	-	32	75	100	140	14	342	132	160	114	80	254	689	246	510	350	390	300	670	M20x1.5	M16x1.5	41
3P 32-200/0.55R	50	95	125	165	16	4	-	32	75	100	140	14	390	160	180	139	80	296	715	272	510	350	390	300	670	M25x1.5	M20x1.5	53.5
3P 32-200/0.55	50	95	125	165	16	4	-	32	75	100	140	14	390	160	180	139	80	296	715	272	510	350	390	300	670	M25x1.5	M20x1.5	53.5
3P 32-200/0.75	50	95	125	165	16	4	-	32	75	100	140	14	390	160	180	139	80	296	715	272	510	350	390	300	670	M25x1.5	M20x1.5	54.5
3P 40-125/0.37R	65	115	145	185	16	4	-	40	80	110	150	14	302	112	140	114	80	213	689	246	550	300	340	250	710	M20x1.5	M16x1.5	46.5
3P 40-125/0.37	65	115	145	185	16	4	-	40	80	110	150	14	302	112	140	114	80	213	689	246	550	300	340	250	710	M20x1.5	M16x1.5	46.5
3P 40-160/0.55R	65	115	145	185	16	4	-	40	80	110	150	14	342	132	160	139	80	254	715	272	510	350	390	300	670	M25x1.5	M20x1.5	44.5
3P 40-160/0.55	65	115	145	185	16	4	-	40	80	110	150	14	342	132	160	139	80	254	715	272	510	350	390	300	670	M25x1.5	M20x1.5	44.5
3P 40-200/1.1R	65	115	145	185	16	4	-	40	80	110	150	14	390	160	180	148	100	296	780	317	590	350	390	300	750	M25x1.5	M20x1.5	59.3
3P 40-200/1.1	65	115	145	185	16	4	-	40	80	110	150	14	390	160	180	148	100	296	780	317	590	350	390	300	750	M25x1.5	M20x1.5	59.3
3P 40-200/1.5	65	115	145	185	16	4	-	40	80	110	150	14	390	160	180	148	100	296	780	317	590	350	390	300	750	M25x1.5	M20x1.5	61.4
3P 50-125/0.55R	65	115	145	185	16	4	-	50	95	125	165	16	342	132	160	139	100	254	735	272	510	350	390	300	670	M25x1.5	M20x1.5	45
3P 50-125/0.55	65	115	145	185	16	4	-	50	95	125	165	16	342	132	160	139	100	254	735	272	510	350	390	300	670	M25x1.5	M20x1.5	45
3P 50-160/1.1R	65	115	145	185	16	4	-	50	95	125	165	16	390	160	180	148	100	296	780	317	590	350	390	300	750	M25x1.5	M20x1.5	50.3
3P 50-160/1.1	65	115	145	185	16	4	-	50	95	125	165	16	390	160	180	148	100	296	780	317	590	350	390	300	750	M25x1.5	M20x1.5	50.3
3P 50-200/1.5R	65	115	145	185	16	4	-	50	95	125	165	16	410	160	200	148	100	296	780	317	590	350	390	300	750	M25x1.5	M20x1.5	61.4
3P 50-200/1.5	65	115	145	185	16	4	-	50	95	125	165	16	410	160	200	148	100	296	780	317	590	350	390	300	750	M25x1.5	M20x1.5	61.4
3P 50-200/2.2	65	115	145	185	16	4	-	50	95	125	165	16	410	160	200	155	100	296	829	366	590	350	390	300	750	M25x1.5	M20x1.5	70.4
3P 65-125/0.55	80	134	160	200	18	8	4	65	115	145	185	16	390	160	180	139	100	254	735	272	510	350	390	300	670	M25x1.5	M20x1.5	48.5
3P 65-125/0.75	80	134	160	200	18	8	4	65	115	145	185	16	390	160	180	139	100	254	735	272	510	350	390	300	670	M25x1.5	M20x1.5	48.5
3P 65-125/1.1	80	134	160	200	18	8	4	65	115	145	185	16	390	160	180	148	100	254	780	317	590	350	390	300	750	M25x1.5	M20x1.5	53.8
3P 65-160/1.1	80	134	160	200	18	8	4	65	115	145	185	16	410	160	200	148	100	296	780	317	590	350	390	300	750	M25x1.5	M20x1.5	60.3
3P 65-160/1.5	80	134	160	200	18	8	4	65	115	145	185	16	410	160	200	148	100	296	780	317	590	350	390	300	750	M25x1.5	M20x1.5	60.9
3P 65-160/2.2	80	134	160	200	18	8	4	65	115	145	185	16	410	160	200	155	100	296	829	366	590	350	390	300	750	M25x1.5	M20x1.5	71.9
3P 65-200/2.2R	80	134	160	200	18	8	4	65	115	145	185	16	455	180	225	155	100	296	829	366	590	380	420	330	750	M25x1.5	M20x1.5	74.4
3P 65-200/2.2	80	134	160	200	18	8	4	65	115	145	185	16	455	180	225	155	100	296	829	366	590	380	420	330	750	M25x1.5	M20x1.5	74.4
3P 65-200/3	80	134	160	200	18	8	4	65	115	145	185	16	455	180	225	155	100	296	829	366	590	380	420	330	750	M25x1.5	M20x1.5	77.5

[1] Standard [2] On request

PUMP 3LP4 65-250, 80

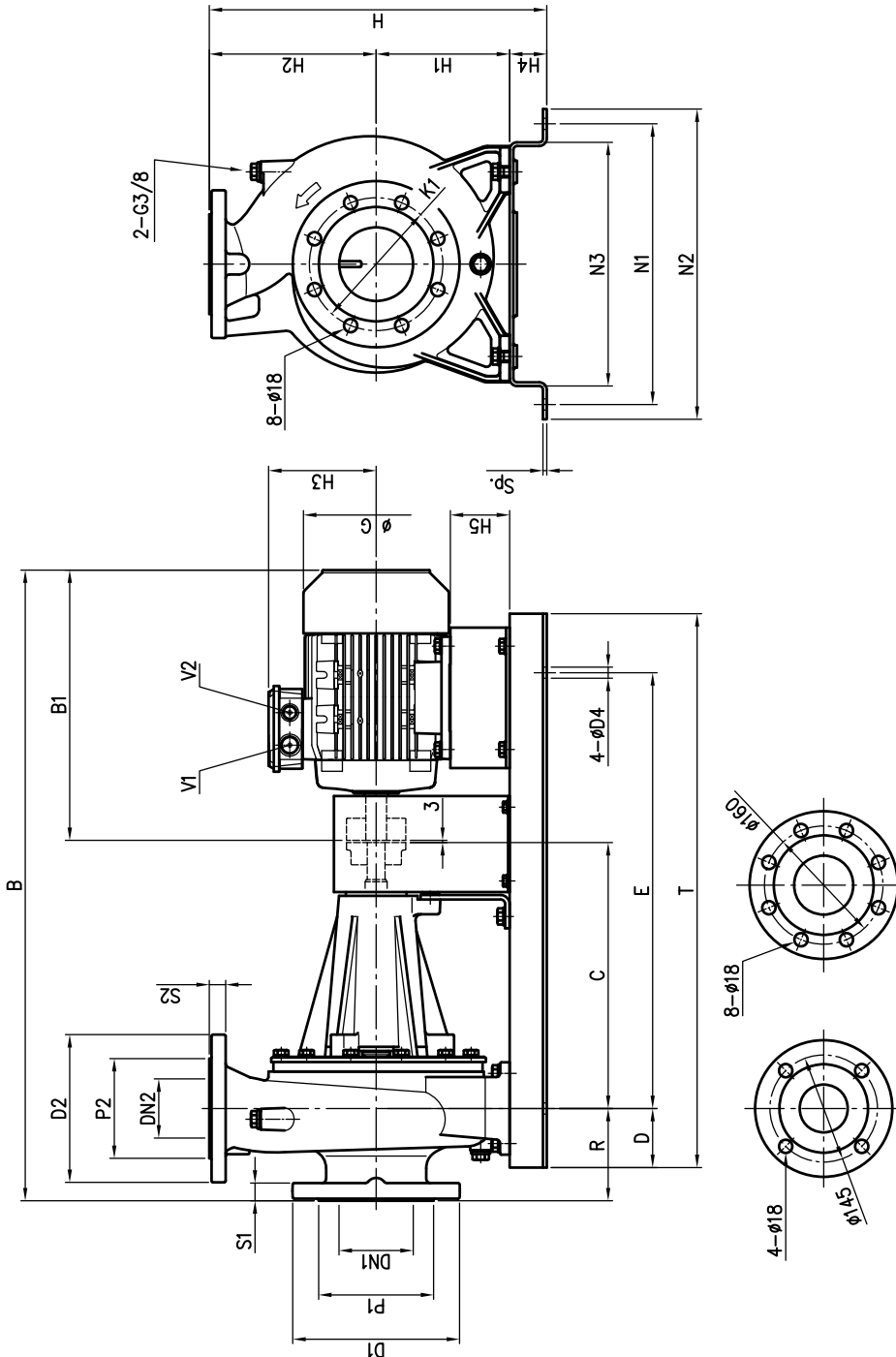

Fig. 2

Fig. 1

Pump type	Dimensions [mm]																				Weight [kg]									
	DN1	P1	D1	S1	DN2	P2	D2	S2	H	H1	H2	H3	H4	H5	R	N1	N2	N3	B	B1		C	D	G	E	T	D4	Sp.	V1	V2
65-250/4	80	135	200	22	65 Fig. 1	120	185	20	510	200	250	171	60	88	100	510	570	440	981	388	470	100	225	760	960	19	8	M25x1.5	M20x1.5	119.1
65-250/5.5	80	135	200	22	65 Fig. 1	120	185	20	510	200	250	198	60	68	100	510	570	440	###	442	470	100	248	760	960	19	8	M32x1.5	M32x1.5	140
80-160/1.5	100	155	225	24	80 Fig. 2	135	200	22	455	180	225	148	50	90	125	380	420	330	805	317	360	80	180	590	750	15	5	M25x1.5	M20x1.5	77.4
80-160/2.2R	100	155	225	24	80 Fig. 2	135	200	22	455	180	225	155	50	80	125	380	420	330	854	366	360	80	196	590	750	15	5	M25x1.5	M20x1.5	86.4
80-160/2.2	100	155	225	24	80 Fig. 2	135	200	22	455	180	225	155	50	80	125	380	420	330	854	366	360	80	196	590	750	15	5	M25x1.5	M20x1.5	100.9
80-200/3	100	155	225	24	80 Fig. 2	135	200	22	490	180	250	155	60	80	125	460	520	390	964	366	470	100	196	700	900	19	8	M25x1.5	M20x1.5	109.5
80-200/4R	100	155	225	24	80 Fig. 2	135	200	22	490	180	250	171	60	68	125	460	520	390	966	388	470	100	225	700	900	19	8	M25x1.5	M20x1.5	122.1
80-200/4	100	155	225	24	80 Fig. 2	135	200	22	490	180	250	171	60	68	125	460	520	390	966	388	470	100	225	700	900	19	8	M25x1.5	M20x1.5	122.6
80-250/5.5R	100	155	225	24	80 Fig. 2	135	200	22	540	200	280	198	60	68	125	510	570	440	###	442	470	100	248	760	960	19	8	M32x1.5	M32x1.5	144
80-250/5.5	100	155	225	24	80 Fig. 2	135	200	22	540	200	280	198	60	68	125	510	570	440	###	442	470	100	248	760	960	19	8	M32x1.5	M32x1.5	144.5
80-250/7.5	100	155	225	24	80 Fig. 2	135	200	22	540	200	280	198	60	68	125	510	570	440	###	502	470	100	248	760	960	19	8	M32x1.5	M32x1.5	157.5

[1] Standard [2] On request

PACKING 3(.)M4

Pump type	Packing [mm]			Weight [kg]	Pack type	
	Z	X	Y			
32-125/0.25	450	250	300	19.3	1	
32-160/0.37R	430	280	340	24.4		
32-160/0.37				24.4		
32-200/0.55R	500	330	390	28.7		
32-200/0.55				28.7		
32-200/0.75				31		
40-125/0.37R	450	250	300	18.2		
40-125/0.37				18.2		
40-160/0.55R	430	280	340	25.6		
40-160/0.55				25.6		
40-200/1.1R	500	330	390	31.7		
40-200/1.1				31.8		
40-200/1.5	580	350	416	33		2
50-125/0.55R	430	280	340	24.8		1
50-125/0.55				24.8		
50-160/1.1R	500	330	390	31.5		
50-160/1.1				31.6		
50-200/1.5R				32.7		
50-200/1.5				33.8		
50-200/2.2	580	350	416	32.7	2	
65-125/0.55	500	330	390	26.6	1	
65-125/0.75				22		
65-125/1.1				26.5		
65-160/1.1				31		
65-160/1.5	580	350	416	34	2	
65-160/2.2	500	330	390	35	1	
65-200/2.2R	600	390	533	35	2	
65-200/2.2				35		
65-200/3				40		
65-250/4	760	455	613	92		
65-250/5.5				106		
80-160/1.5				58		
80-160/2.2R	580	370	538	58	2	
80-160/2.2				58		
80-200/3	760	455	613	78		
80-250/4R				85		
80-250/4				86		
80-250/5.5R				99		
80-250/5.5				103		
80-250/7.5				124		

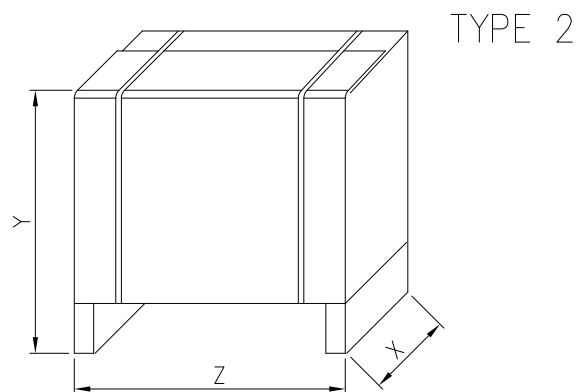
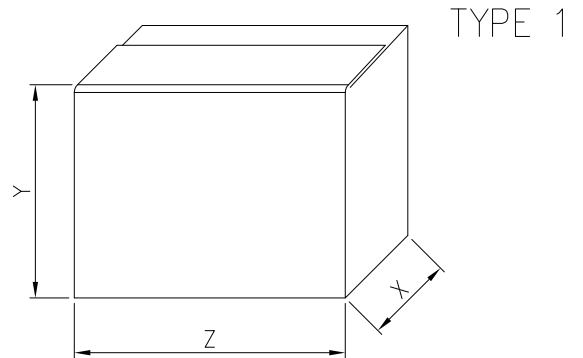

PACKING 3(.)S4

Pump type	Packing [mm]			Weight [kgf]	Pack type
	Z	X	Y		
32-125/0.25	450	250	300	17.5	1
32-160/0.37R	490	280	340	21.3	
32-160/0.37	430	280	330	21.3	
32-200/0.55R	500	330	390	34.3	
32-200/0.55				34.3	
32-200/0.75				32.3	
40-125/0.37R	450	250	300	18.5	2
40-125/0.37	450	250	300	18.5	
40-160/0.55R	490	280	340	25.6	
40-160/0.55				25.6	
40-200/1.1R	700	350	498	33.2	
40-200/1.1				33.2	
40-200/1.5				38.1	
50-125/0.55R	490	280	340	26	1
50-125/0.55	490	280	340	26	
50-160/1.1R	700	350	498	37.8	2
50-160/1.1				37.8	
50-200/1.5R				36	
50-200/1.5				36	
50-200/2.2				47.9	
65-125/0.55	580	350	488	28	
65-125/0.75				33	
65-125/1.1				34.9	
65-160/1.1				36.8	
65-160/1.5				37.4	
65-160/2.2				45.4	
65-200/2.2R	600	390	533	50.4	
65-200/2.2				50.4	
65-200/3				50	
65-250/4				10.6	
65-250/5.5	760	455	613	126	2
80-160/1.5	580	370	538	66.9	
80-160/2.2R	680			75.9	
80-160/2.2	680	76.4			
80-200/3	760	455	613	88	
80-200/4R				99.6	
80-200/4				102.6	
80-250/5.5R				134	
80-250/5.5				135	
80-250/7.5				144	

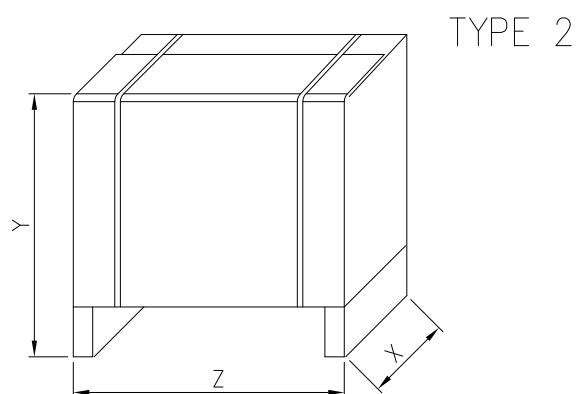
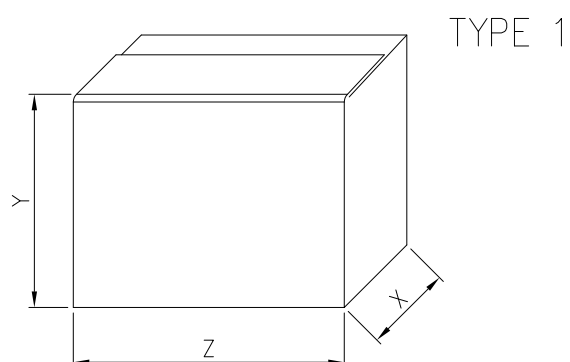

PACKING 3(.)P4

Pump type	Packing [mm]			Weight [kgf]
	Z	X	Y	
32-125/0.25	1200	800	394	37
32-160/0.37R			434	41
32-160/0.37				41
32-200/0.55R			482	53.5
32-200/0.55				53.5
32-200/0.75				54.5
40-125/0.37R			394	46.5
40-125/0.37				46.5
40-160/0.55R			434	44.5
40-160/0.55				44.5
40-200/1.1R			482	59.3
40-200/1.1				59.3
40-200/1.5				61.4
50-125/0.55R			434	45
50-125/0.55				45
50-160/1.1R			482	50.3
50-160/1.1				50.3
50-200/1.5R			502	61.4
50-200/1.5				61.4
50-200/2.2				70.4
65-125/0.55			482	48.6
65-125/0.75				50
65-125/1.1				53.8
65-160/1.1			502	60.3
65-160/1.5				60.9
65-160/2.2				71.9
65-200/2.2R			547	74.4
65-200/2.2				74.4
65-200/3				77.5
65-250/4			635	119.1
65-250/5.5				140
80-160/1.5			580	77.4
80-160/2.2R	83.4			
80-160/2.2	97.9			
80-200/3	615	109.5		
80-200/4R		122.1		
80-200/4		122.6		
80-250/5.5R	665	144		
80-250/5.5		144.5		
80-250/7.5		157.5		

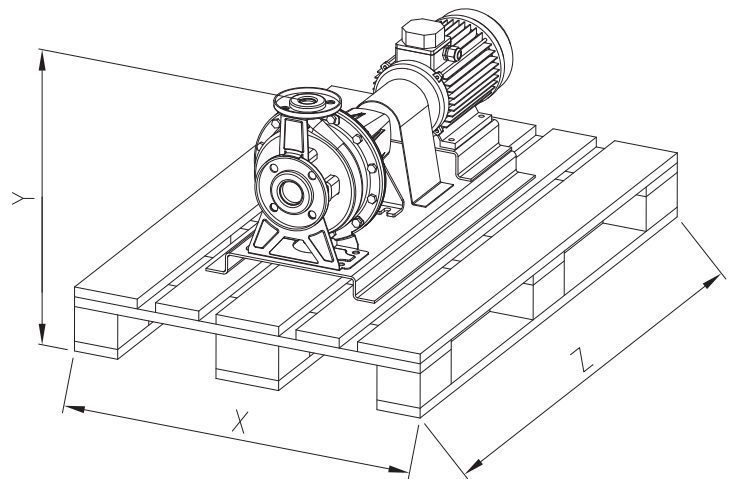

## MOTOR DATA 3(.)M4

Pump type	Motor			Efficiency	Input [kW]	Efficiency (% load) and power-factor				Full load current [A]			Locked rotor current [A]		
	Motor Size	Power				50%	75%	100%	cos-φ	230 V	400 V	690 V	230 V	400 V	690 V
		[kW]	[HP]												
3(.)M4 32-125/0.25	71	0.25	0.33	IE2	0,50	69,4	73,6	74,2	0,71	1,8	1,0	-	7,9	4,5	-
3(.)M4 32-160/0.37R	80	0.37	0.5	IE2	0,71	71,9	75,9	77,7	0,75	2,4	1,4	-	14,8	8,6	-
3(.)M4 32-160/0.37		0.37	0.5	IE2	0,71	71,9	75,9	77,7	0,75	2,4	1,4	-	14,8	8,6	-
3(.)M4 32-200/0.55R	80	0.55	0.75	IE2	0,71	71,9	75,9	77,7	0,75	2,4	1,4	-	14,8	8,6	-
3(.)M4 32-200/0.55		0.55	0.75	IE2	0,71	71,9	75,9	77,7	0,75	2,4	1,4	-	14,8	8,6	-
3(.)M4 32-200/0.75	90	0.75	1	IE3	1,31	81,5	83,4	84,1	0,71	4,6	2,7	-	32,9	19,0	-
3(.)M4 40-125/0.37R	71	0.37	0.5	IE2	0,50	69,4	73,6	74,2	0,71	1,8	1,0	-	7,9	4,5	-
3(.)M4 40-125/0.37		0.37	0.5	IE2	0,50	69,4	73,6	74,2	0,71	1,8	1,0	-	7,9	4,5	-
3(.)M4 40-160/0.55R	80	0.55	0.75	IE2	0,71	71,9	75,9	77,7	0,75	2,4	1,4	-	14,8	8,6	-
3(.)M4 40-160/0.55		0.55	0.75	IE2	0,71	71,9	75,9	77,7	0,75	2,4	1,4	-	14,8	8,6	-
3(.)M4 40-200/1.1R	90	1.1	1.5	IE3	1,31	81,5	83,4	84,1	0,71	4,6	2,7	-	32,9	19,0	-
3(.)M4 40-200/1.1		1.1	1.5	IE3	1,31	81,5	83,4	84,1	0,71	4,6	2,7	-	32,9	19,0	-
3(.)M4 40-200/1.5		1.5	2	IE3	1,76	81,1	84,1	85,3	0,71	6,2	3,6	-	45,0	26,0	-
3(.)M4 50-125/0.55R	80	0.55	0.75	IE2	0,71	71,9	75,9	77,7	0,75	2,4	1,4	-	14,8	8,6	-
3(.)M4 50-125/0.55		0.55	0.75	IE2	0,71	71,9	75,9	77,7	0,75	2,4	1,4	-	14,8	8,6	-
3(.)M4 50-160/1.1R	90	1.1	1.5	IE3	1,31	81,5	83,4	84,1	0,71	4,6	2,7	-	32,9	19,0	-
3(.)M4 50-160/1.1		1.1	1.5	IE3	1,31	81,5	83,4	84,1	0,71	4,6	2,7	-	32,9	19,0	-
3(.)M4 50-200/1.5R		1.5	2	IE3	1,76	81,1	84,1	85,3	0,71	6,2	3,6	-	45,0	26,0	-
3(.)M4 50-200/1.5		1.5	2	IE3	1,76	81,1	84,1	85,3	0,71	6,2	3,6	-	45,0	26,0	-
3(.)M4 50-200/2.2	100	2.2	3	IE3	2,54	86,1	87,0	86,7	0,78	7,8	4,5	-	53,7	31,0	-
3(.)M4 65-125/0.55	80	0.55	0.75	IE2	0,71	71,9	75,9	77,7	0,75	2,4	1,4	-	14,8	8,6	-
3(.)M4 65-125/0.75		0.75	1	IE3	1,31	81,5	83,4	84,1	0,71	4,6	2,7	-	32,9	19,0	-
3(.)M4 65-125/1.1	90	1.1	1.5	IE3	1,31	81,5	83,4	84,1	0,71	4,6	2,7	-	32,9	19,0	-
3(.)M4 65-160/1.1		1.1	1.5	IE3	1,31	81,5	83,4	84,1	0,71	4,6	2,7	-	32,9	19,0	-
3(.)M4 65-160/1.5		1.5	2	IE3	1,76	81,1	84,1	85,3	0,71	6,2	3,6	-	45,0	26,0	-
3(.)M4 65-160/2.2	100	2.2	3	IE3	2,54	86,1	87,0	86,7	0,78	7,8	4,5	-	53,7	31,0	-
3(.)M4 65-200/2.2R		2.2	3	IE3	2,54	86,1	87,0	86,7	0,78	7,8	4,5	-	53,7	31,0	-
3(.)M4 65-200/2.2		2.2	3	IE3	2,54	86,1	87,0	86,7	0,78	7,8	4,5	-	53,7	31,0	-
3(.)M4 65-200/3		3	4	IE3	3,42	85,7	87,7	87,8	0,72	11,8	6,8	-	83,1	48,0	-
3LM4 65-250/4	112	4	5.5	IE3	4,51	85,8	87,6	88,6	0,76	14,4	8,3	-	103,9	60,0	-
3LM4 65-250/5.5	132	5.5	7.5	IE3	6,14	87,2	88,5	89,6	0,78	-	10,9	6,3	-	120,0	69,6
3LM4 80-160/1.5	90	1.5	2	IE3	1,76	81,1	84,1	85,3	0,71	6,2	3,6	-	45,0	26,0	-
3LM4 80-160/2.2R		2.2	3	IE3	2,54	86,1	87,0	86,7	0,78	7,8	4,5	-	53,7	31,0	-
3LM4 80-160/2.2	100	2.2	3	IE3	2,54	86,1	87,0	86,7	0,78	7,8	4,5	-	53,7	31,0	-
3LM4 80-200/3		3,00	4	IE3	3,42	85,7	87,7	87,8	0,72	11,8	6,8	-	83,1	48,0	-
3LM4 80-200/4R	112	4	5.5	IE3	4,51	85,8	87,6	88,6	0,76	14,4	8,3	-	103,9	60,0	-
3LM4 80-200/4	112	4	5.5	IE3	4,51	85,8	87,6	88,6	0,76	14,4	8,3	-	103,9	60,0	-
3LM4 80-250/5.5R	132	5.5	7.5	IE3	6,14	87,2	88,5	89,6	0,78	-	10,9	6,3	-	120,0	69,6
3LM4 80-250/5.5		5.5	7.5	IE3	6,14	87,2	88,5	89,6	0,78	-	10,9	6,3	-	120,0	69,6
3LM4 80-250/7.5	132M	7.5	10	IE3	8,27	89,8	90,9	90,4	0,78	-	15,3	8,8	-	125,5	72,4



## MOTOR DATA 3(.)S4-3(.)P4

Pump type		Motor size	Motor Power		Efficiency	Input [kW]	Efficiency (% load) and power-factor				Full load current [A]			Locked rotor current [A]		
			[kW]	[HP]			50%	75%	100%	cos-φ	230 V	400 V	690 V	230 V	400 V	690 V
3(.)S4 32-125/0.25	3(.)P4 32-125/0.25	71	0.25	0.33	IE2	0.36	67,1	71,2	68,5	0,77	1,2	0,7	-	3,8	2,2	-
3(.)S4 32-160/0.37R	3(.)P4 32-160/0.37R		0.37	0.5	IE2	0.50	68,4	73,3	72,7	0,70	1,8	1,1	-	5,9	3,5	-
3(.)S4 32-160/0.37	3(.)P4 32-160/0.37	80	0.37	0.5	IE2	0.50	68,4	73,3	72,7	0,70	1,8	1,1	-	5,9	3,5	-
3(.)S4 32-200/0.55R	3(.)P4 32-200/0.55R		0.55	0.75	IE2	0.71	75,1	77,8	77,1	0,72	2,6	1,5	-	9,4	5,4	-
3(.)S4 32-200/0.55	3(.)P4 32-200/0.55	71	0.55	0.75	IE2	0.71	75,1	77,8	77,1	0,72	2,6	1,5	-	9,4	5,4	-
3(.)S4 32-200/0.75	3(.)P4 32-200/0.75		0.75	1	IE3	0.92	80,7	81,5	82,5	0,74	3,1	1,8	-	17,3	10,0	-
3(.)S4 40-125/0.37R	3(.)P4 40-125/0.37R	80	0.37	0.5	IE2	0.50	68,4	73,3	72,7	0,70	1,8	1,1	-	5,9	3,5	-
3(.)S4 40-125/0.37	3(.)P4 40-125/0.37		0.37	0.5	IE2	0.50	68,4	73,3	72,7	0,70	1,8	1,1	-	5,9	3,5	-
3(.)S4 40-160/0.55R	3(.)P4 40-160/0.55R	90S	0.55	0.75	IE2	0.71	75,1	77,8	77,1	0,72	2,6	1,5	-	9,4	5,4	-
3(.)S4 40-160/0.55	3(.)P4 40-160/0.55		0.55	0.75	IE2	0.71	75,1	77,8	77,1	0,72	2,6	1,5	-	9,4	5,4	-
3(.)S4 40-200/1.1R	3(.)P4 40-200/1.1R	90L	1.1	1.5	IE3	1.30	83,3	84,3	84,1	0,75	4,3	2,5	-	30,7	17,7	-
3(.)S4 40-200/1.1	3(.)P4 40-200/1.1		1.1	1.5	IE3	1.30	83,3	84,3	84,1	0,75	4,3	2,5	-	30,7	17,7	-
3(.)S4 40-200/1.5	3(.)P4 40-200/1.5	80	1.5	2	IE3	1.80	84,1	85,2	85,3	0,72	6,2	3,6	-	41,0	23,7	-
3(.)S4 50-125/0.55R	3(.)P4 50-125/0.55R		0.55	0.75	IE2	0.71	75,1	77,8	77,1	0,72	2,6	1,5	-	9,4	5,4	-
3(.)S4 50-125/0.55	3(.)P4 50-125/0.55	90S	0.55	0.75	IE2	0.71	75,1	77,8	77,1	0,72	2,6	1,5	-	9,4	5,4	-
3(.)S4 50-160/1.1R	3(.)P4 50-160/1.1R		1.1	1.5	IE3	1.30	83,3	84,3	84,1	0,75	4,3	2,5	-	30,7	17,7	-
3(.)S4 50-160/1.1	3(.)P4 50-160/1.1	90L	1.1	1.5	IE3	1.30	83,3	84,3	84,1	0,75	4,3	2,5	-	30,7	17,7	-
3(.)S4 50-200/1.5R	3(.)P4 50-200/1.5R		1.5	2	IE3	1.80	84,1	85,2	85,3	0,72	6,2	3,6	-	41,0	23,7	-
3(.)S4 50-200/1.5	3(.)P4 50-200/1.5	100L	1.5	2	IE3	1.80	84,1	85,2	85,3	0,72	6,2	3,6	-	41,0	23,7	-
3(.)S4 50-200/2.2	3(.)P4 50-200/2.2		2.2	3	IE3	2.58	83,2	86,2	86,7	0,63	10,2	5,9	-	73,6	42,5	-
3(.)S4 65-125/0.55	3(.)P4 65-125/0.55	80	0.55	0.75	IE2	0.71	75,1	77,8	77,1	0,72	2,6	1,5	-	9,4	5,4	-
3(.)S4 65-125/0.75	3(.)P4 65-125/0.75		0.75	1	IE3	0.92	80,7	81,5	82,5	0,74	3,1	1,8	-	17,3	10,0	-
3(.)S4 65-125/1.1	3(.)P4 65-125/1.1	90S	1.1	1.5	IE3	1.30	83,3	84,3	84,1	0,75	4,3	2,5	-	30,7	17,7	-
3(.)S4 65-160/1.1	3(.)P4 65-160/1.1		1.1	1.5	IE3	1.30	83,3	84,3	84,1	0,75	4,3	2,5	-	30,7	17,7	-
3(.)S4 65-160/1.5	3(.)P4 65-160/1.5	100L	1.5	2	IE3	1.80	84,1	85,2	85,3	0,72	6,2	3,6	-	41,0	23,7	-
3(.)S4 65-160/2.2	3(.)P4 65-160/2.2		2.2	3	IE3	2.58	83,2	86,2	86,7	0,63	10,2	5,9	-	73,6	42,5	-
3(.)S4 65-200/2.2R	3(.)P4 65-200/2.2R	112M	2.2	3	IE3	2.58	83,2	86,2	86,7	0,63	10,2	5,9	-	73,6	42,5	-
3(.)S4 65-200/2.2	3(.)P4 65-200/2.2		2.2	3	IE3	2.58	83,2	86,2	86,7	0,63	10,2	5,9	-	73,6	42,5	-
3(.)S4 65-200/3	3(.)P4 65-200/3	132S	3	4	IE3	3.44	85,1	87,1	87,7	0,73	11,8	6,8	-	95,4	55,1	-
3LS4 65-250/4	3LP4 65-250/4		4	5.5	IE3	4.54	87,2	88,3	88,6	0,80	14,2	8,2	-	120,7	69,7	-
3LS4 65-250/5.5	3LP4 65-250/5.5	90L	5.5	7.5	IE3	6.17	89,8	90,2	89,6	0,84	-	10,6	6,1	-	92,2	53,2
3LS4 80-160/1.5	3LP4 80-160/1.5		1.5	2	IE3	1.80	84,1	85,2	85,3	0,72	6,2	3,6	-	41,0	23,7	-
3LS4 80-160/2.2R	3LP4 80-160/2.2R	100L	2.2	3	IE3	2.58	83,2	86,2	86,7	0,63	10,2	5,9	-	73,6	42,5	-
3LS4 80-160/2.2	3LP4 80-160/2.2		2.2	3	IE3	2.58	83,2	86,2	86,7	0,63	10,2	5,9	-	73,6	42,5	-
3LS4 80-200/3	3LP4 80-200/3	112M	3	4	IE3	3.44	85,1	87,1	87,7	0,73	11,8	6,8	-	95,4	55,1	-
3LS4 80-200/4R	3LP4 80-200/4R		4	5.5	IE3	4.54	87,2	88,3	88,6	0,80	14,2	8,2	-	120,7	69,7	-
3LS4 80-200/4	3LP4 80-200/4	132S	4	5.5	IE3	4.54	87,2	88,3	88,6	0,80	14,2	8,2	-	120,7	69,7	-
3LS4 80-250/5.5R	3LP4 80-250/5.5R		5.5	7.5	IE3	6.17	89,8	90,2	89,6	0,84	-	10,6	6,1	-	92,2	53,2
3LS4 80-250/5.5	3LP4 80-250/5.5	132M	5.5	7.5	IE3	6.17	89,8	90,2	89,6	0,84	-	10,6	6,1	-	92,2	53,2
3LS4 80-250/7.5	3LP4 80-250/7.5		7.5	10	IE3	8.27	89,8	90,9	90,4	0,78	-	15,3	8,8	-	125,5	72,4

## NOISE DATA 3(.)M4

Pump type	Power		LpA - dB(A) *
	[kW]	[HP]	
3(.)M4 32-125/0.25	0.25	0.33	<70
3(.)M4 32-160/0.37R	0.37	0.5	
3(.)M4 32-160/0.37	0.37	0.5	
3(.)M4 32-200/0.55R	0.55	0.75	
3(.)M4 32-200/0.55	0.55	0.75	
3(.)M4 32-200/0.75	0.75	1	
3(.)M4 40-125/0.37R	0.37	0.5	
3(.)M4 40-125/0.37	0.37	0.5	
3(.)M4 40-160/0.55R	0.55	0.75	
3(.)M4 40-160/0.55	0.55	0.75	
3(.)M4 40-200/1.1R	1.1	1.5	
3(.)M4 40-200/1.1	1.1	1.5	
3(.)M4 40-200/1.5	1.5	2	
3(.)M4 50-125/0.55R	0.55	0.75	
3(.)M4 50-125/0.55	0.55	0.75	
3(.)M4 50-160/1.1R	1.1	1.5	
3(.)M4 50-160/1.1	1.1	1.5	
3(.)M4 50-200/1.5R	1.5	2	
3(.)M4 50-200/1.5	1.5	2	
3(.)M4 50-200/2.2	2.2	3	
3(.)M4 65-125/0.55	0.55	0.75	
3(.)M4 65-125/0.75	0.75	1	
3(.)M4 65-125/1.1	1.1	1.5	
3(.)M4 65-160/1.1	1.1	1.5	
3(.)M4 65-160/1.5	1.5	2	
3(.)M4 65-160/2.2	2.2	3	
3(.)M4 65-200/2.2R	2.2	3	
3(.)M4 65-200/2.2	2.2	3	
3(.)M4 65-200/3	3	4	
3LM4 65-250/4	4	5.5	
3LM4 65-250/5.5	5.5	7.5	71
3LM4 80-160/1.5	1.5	2	<70
3LM4 80-160/2.2R	2.2	3	
3LM4 80-160/2.2	2.2	3	
3LM4 80-200/3	3	4	
3LM4 80-200/4R	4	5.5	
3LM4 80-200/4	4	5.5	
3LM4 80-250/5.5R	5.5	7.5	71
3LM4 80-250/5.5	5.5	7.5	71
3LM4 80-250/7.5	7.5	10	<70**

\*Mean value of several measures at 1m distance around the pump.

Tolerance  $\pm 2.5$  dB.

\*\* Sound pressure level of motor pumps with AEG

**NOISE DATA 3(.)S4-3(.)P4**

Pump type		Power		LpA - dB(A) *
3(.)S4	3(.)P4	[kW]	[HP]	
3(.)S4 32-125/0.25	3(.)P4 32-125/0.25	0.25	0.33	<70
3(.)S4 32-160/0.37R	3(.)P4 32-160/0.37R	0.37	0.5	
3(.)S4 32-160/0.37	3(.)P4 32-160/0.37	0.37	0.5	
3(.)S4 32-200/0.55R	3(.)P4 32-200/0.55R	0.55	0.75	
3(.)S4 32-200/0.55	3(.)P4 32-200/0.55	0.55	0.75	
3(.)S4 32-200/0.75	3(.)P4 32-200/0.75	0.75	1	
3(.)S4 40-125/0.37R	3(.)P4 40-125/0.37R	0.37	0.5	
3(.)S4 40-125/0.37	3(.)P4 40-125/0.37	0.37	0.5	
3(.)S4 40-160/0.55R	3(.)P4 40-160/0.55R	0.55	0.75	
3(.)S4 40-160/0.55	3(.)P4 40-160/0.55	0.55	0.75	
3(.)S4 40-200/1.1R	3(.)P4 40-200/1.1R	1.1	1.5	
3(.)S4 40-200/1.1	3(.)P4 40-200/1.1	1.1	1.5	
3(.)S4 40-200/1.5	3(.)P4 40-200/1.5	1.5	2	
3(.)S4 50-125/0.55R	3(.)P4 50-125/0.55R	0.55	0.75	
3(.)S4 50-125/0.55	3(.)P4 50-125/0.55	0.55	0.75	
3(.)S4 50-160/1.1R	3(.)P4 50-160/1.1R	1.1	1.5	
3(.)S4 50-160/1.1	3(.)P4 50-160/1.1	1.1	1.5	
3(.)S4 50-200/1.5R	3(.)P4 50-200/1.5R	1.5	2	
3(.)S4 50-200/1.5	3(.)P4 50-200/1.5	1.5	2	
3(.)S4 50-200/2.2	3(.)P4 50-200/2.2	2.2	3	
3(.)S4 65-125/0.55	3(.)P4 65-125/0.55	0.55	0.75	
3(.)S4 65-125/0.75	3(.)P4 65-125/0.75	0.75	1	
3(.)S4 65-125/1.1	3(.)P4 65-125/1.1	1.1	1.5	
3(.)S4 65-160/1.1	3(.)P4 65-160/1.1	1.1	1.5	
3(.)S4 65-160/1.5	3(.)P4 65-160/1.5	1.5	2	
3(.)S4 65-160/2.2	3(.)P4 65-160/2.2	2.2	3	
3(.)S4 65-200/2.2R	3(.)P4 65-200/2.2R	2.2	3	
3(.)S4 65-200/2.2	3(.)P4 65-200/2.2	2.2	3	
3(.)S4 65-200/3	3(.)P4 65-200/3	3	4	
3LS4 65-250/4	3LP4 65-250/4	4	5.5	
3LS4 65-250/5.5	3LP4 65-250/5.5	5.5	7.5	
3LS4 80-160/1.5	3LP4 80-160/1.5	1.5	2	
3LS4 80-160/2.2R	3LP4 80-160/2.2R	2.2	3	
3LS4 80-160/2.2	3LP4 80-160/2.2	2.2	3	
3LS4 80-200/3	3LP4 80-200/3	3	4	
3LS4 80-200/4R	3LP4 80-200/4R	4	5.5	
3LS4 80-200/4	3LP4 80-200/4	4	5.5	
3LS4 80-250/5.5R	3LP4 80-250/5.5R	5.5	7.5	
3LS4 80-250/5.5	3LP4 80-250/5.5	5.5	7.5	
3LS4 80-250/7.5	3LP4 80-250/7.5	7.5	10	

\*Mean value of several measures at 1m distance around the pump.

Tolerance  $\pm 2.5$  dB.

Sound pressure level of motor pumps with AEG



**EBARA Pumps Europe S.p.A.**  
Via Torri di Confine 2/1 int. C  
36053 Gambellara (Vicenza), Italy  
Phone +39 0444 706811  
ebarapumps.epe@ebaracom  
www.ebaraeurope.com

**EBARA Pumps Europe S.p.A. GERMANY**  
Elisabeth-Selbert-Straße 2  
63110 Rodgau, Germany  
Phone +49 (0) 6106-660 99-0  
info.epde@ebaracom

**EBARA Pumps South Africa (PTY) LTD**  
26 Kyalami Boulevard,  
Kyalami Business Park, 1684, Midrand,  
Gauteng, South Africa  
Phone +27 11 466 1844  
ebaraeurope@ebaracom

**EBARA Pumps Europe S.p.A. UK**  
Unit A, Park 34  
Collett Way - Didcot  
Oxfordshire - OX11 7WB, United Kingdom  
Phone +44 1895 439027  
marketing.epuk@ebaracom

**EBARA Pumps Europe S.p.A. FRANCE**  
122, Rue Pasteur  
69780 Toussieu, France  
Phone: +33 04 72 76 94 82  
mktg.epr@ebaracom

**EBARA Pumps East Africa**  
Delta Corner Tower 2, 13th Floor, Office 1308,  
Chiromo Road, Westlands  
P.O. Box 13796-00800, Nairobi  
Phone: +254(0)722913119  
info.epea@ebaracom

**EBARA POMPY POLSKA Sp. z o.o.**  
ul. Działkowa 115 A  
02-234 Warszawa, Poland  
Phone +48 22 3909920  
marketing.epl@ebaracom

**EBARA Pumps RUS Ltd.**  
Prospekt Andropov 18, building 7, floor 11  
115432 Moscow  
Phone +7 499 6830133  
mktg.epr@ebaracom