

EBARA

	Page
- SPECIFICATION	
SPECIFICATION	200-201-202
PERFORMANCE RANGE	203
SELECTION CHART	204
TYPE KEY	205
PERFORMANCE CURVE SPECIFICATION	206
MEI INDEX SPECIFICATION	207
PERFORMANCE CURVE 32-125	208
PERFORMANCE CURVE 32-160	209
PERFORMANCE CURVE 32-200	210
PERFORMANCE CURVE 40-125	211
PERFORMANCE CURVE 40-160	212
PERFORMANCE CURVE 40-200	213
PERFORMANCE CURVE 50-125	214
PERFORMANCE CURVE 50-160	215
PERFORMANCE CURVE 50-200	216
PERFORMANCE CURVE 65-125	217
PERFORMANCE CURVE 65-160	218
PERFORMANCE CURVE 65-200	219
PERFORMANCE CURVE 65-250	220
PERFORMANCE CURVE 80-160	221
PERFORMANCE CURVE 80-200	222
PERFORMANCE CURVE 80-250	223
- CONSTRUCTION	
SECTIONAL VIEW DRAWING 3(.)M4 32, 40, 50, 65-125/160/200	300
SECTIONAL VIEW TABLE 3(.)M4 32, 40, 50, 65-125/160/200	301
SECTIONAL VIEW DRAWING 3LM4 80-160	302
SECTIONAL VIEW TABLE 3LM4 80-160	303
SECTIONAL VIEW DRAWING 3LM4 65-250, 80-200/250	304
SECTIONAL VIEW TABLE 3LM4 65-250, 80-200/250	305
SECTIONAL VIEW DRAWING 3(.)S4 32, 40, 50, 65-125/160/200	306
SECTIONAL VIEW TABLE 3(.)S4 32, 40, 50, 65-125/160/200	307
SECTIONAL VIEW DRAWING 3LS4 80-160	308
SECTIONAL VIEW TABLE 3LS4 80-160	309
SECTIONAL VIEW DRAWING 3LS4 65-250, 80-200/250	310
SECTIONAL VIEW TABLE 3LS4 65-250, 80-200/250	311
SECTIONAL VIEW DRAWING 3(.)P4 32, 40, 50, 65-125/160/200	312
SECTIONAL VIEW TABLE 3(.)P4 32, 40, 50, 65-125/160/200	313
SECTIONAL VIEW DRAWING 3LP4 80-160	314
SECTIONAL VIEW DRAWING 3LP4 65-250, 80-200/250	315
SECTIONAL VIEW DRAWING 3LP4 65-250, 80-160/200/250	316
SECTIONAL VIEW TABLE 3LP4 80-160	317
SECTIONAL VIEW TABLE 3LP4 65-250, 80-200/250	318

BEARINGS 3(.)M4-3(.)S4	319
BEARINGS 3(.)P4	320
MECHANICAL SEAL (standard, H and special version)	321
MECHANICAL SEAL (L version Ø 22)	322
MECHANICAL SEAL (L version Ø 30)	323
MECHANICAL SEAL (HS version e special version Ø22)	324
MECHANICAL SEAL (HW, HSW, E and special version)	325
COUPLING 3(.)S4	326
FLEXIBLE COUPLING 3(.)P4	327
FITTINGS	328-329
- DIMENSIONS AND WEIGHT	
PUMP 3(.)M4 32, 40, 50, 65-125/160/200	400
PUMP 3(.)M4 65-250, 80-160/200, 80-250/5.5	401
PUMP 3(.)M4 80-250/7.5	402
PUMP 3(.)S4 32, 40, 50, 65-125/160	403
PUMP 3(.)S4 50, 65-160/200	404
PUMP 3LS4 65-250, 80-160/200/250	405
PUMP 3LS4 80-160/1.5	406
PUMP 3(.)P4 32, 40, 50, 65-125/160/200	407
PUMP 3LP4 65-250, 80	408
PACKING 3(.)M4	409
PACKING 3(.)S4	410
PACKING 3(.)P4	411
- TECHNICAL DATA	
MOTOR DATA 3(.)M4	500
MOTOR DATA 3(.)S4-3(.)P4	501
NOISE DATA 3(.)M4	502
NOISE DATA 3(.)S4-3(.)P4	503

Version		3M4	3S4	3P4	3LM4	3LS4	3LP4
Pump sizes	32-125	■	■	■	●	●	●
	32-160	■	■	■	●	●	●
	32-200	■	■	■	●	●	●
	40-125	■	■	■	●	●	●
	40-160	■	■	■	●	●	●
	40-200	■	■	■	●	●	●
	50-125	■	■	■	●	●	●
	50-160	■	■	■	●	●	●
	50-200	■	■	■	●	●	●
	65-125	■	■	■	●	●	●
	65-160	■	■	■	●	●	●
	65-200	■	■	■	●	●	●
	65-250	-	-	-	●	●	●
	80-160	-	-	-	●	●	●
	80-200	-	-	-	●	●	●
80-250	-	-	-	●	●	●	

■ Available also with H, HS, HW, HSW, E version.

● Available also with H, HW, HSW, E version.

— Not available.

SPECIFICATION

50Hz

Rev. L

				PUMP					
Version				3M4	3S4	3P4	3LM4	3LS4	3LP4
Liquid Handled	Type of liquid				Clean water and moderately aggressive fluids				
	Temperature [°C]				/		Drinking water and water contains glycol for E option		
					min. -10 min. -20 (E version) max. +90 (Q1Q1EGG, Q1U3EGG, Q1AEGG, U3U3EGG, U3CEGG) max. +110 (H-HS-HW-HSW version) max. +120 (E version) (For version see page 321÷325)			min. -10 min. -20 (E version) max. +110 (L, Q1Q13GG, Q1U3EGG, Q1AEGG, U3U3EGG, U3CEGG) max. +110 (H-HW-HSW version) max. +120 (E version) (For version see page 321÷325)	
Maximum working pressure [MPa]				1					
Construction	Impeller				Closed centrifugal type for 32, 40, 50 version Reinforced laser welding for 40-200/1.5, 50-200/2.2 Closed centrifugal three dimensional blades for 65 and 80 version				
	Shaft seal type				Mechanical seal			Mechanical seal with stationary ring secured against rotation	
	Bearing				Bearing with contact seal				
Pipe Connection	Suction	32-125/160/200		Flange DN50 according DIN 2532 Standard					
		40-125/160/200		Flange DN65 according DIN 2532 Standard					
		50-125/160/200		Flange DN80 according DIN 2532 Standard					
	Discharge	65-125/160/200/250		Flange DN100 according DIN 2532 Standard					
		80-160/200/250		Flange DN32 according DIN 2532 Standard					
		32-125/160/200		Flange DN40 according DIN 2532 Standard					
Material	Casing	32-125/160/200		EN 1.4301 (AISI 304)			EN 1.4404 (AISI 316L)		
		40-125/160/200					EN 1.4401 (AISI 316) made by precision casting		
		50-125/160/200							
	Impeller	65-125/160/200					EN 1.4401 (AISI 316) made by precision casting		
		65-250					EN 1.4401 (AISI 316) made by precision casting		
		80-160/200/250							
	Casing cover	32-125/160/200		EN 1.4301 (AISI 304)			EN 1.4404 (AISI 316L)		
		40-125/160/200					EN 1.4401 (AISI 316) made by precision casting		
		50-125/160/200							
	Mechanical seal	65-125/160/200		Ceramic/Carbon/NBR (See page 321÷325)			SiC/SiC/FPM (L version) (See page 321÷325)		
		65-250							
		80-160/200/250							
O-ring				NBR (See page 321÷325)			FPM (See page 321÷325)		
Shaft	32, 40, 50, 65	d=19	EN 1.4301 (AISI 304)			EN 1.4404 (AISI 316L)			
	50-200/2.2	d=22							
	80-160	d=19							
	65-250	d=24							
Bracket				Cast iron - Aluminium					
Applicable standard of test				ISO 9906:2012 – Grade 3B					

SPECIFICATION

50Hz

Rev. L

MOTOR			
	3(.)M4	3(.)S4	3(.)P4
Type	Electric - TEFC Three Phase		
Efficiency level (Reg. 640/2009)	- from 0.25 kW up to 0.55 kW IE2 from 0.75 kW up to 5.5 kW		
	IE3 only for 7.5 kW	IE3 from 0.75 kW up to 7.5 kW	
No. of Poles	4		
Rotation speed [min ⁻¹]	≈ 1400		
Insulation Class	F (class B for temperature rise)		
Protection degree (CEI EN 60034-5)	IP 55		
Power rating [kW]	0.25 ÷ 7.5		
[HP]	0.33 ÷ 10		
Frequency [Hz]	50		
Voltage [V]	230/400 ±10% (up to 4.0 kW) 400/690 ±10% (5.5 kW and above)		
Over load protection	Provided by the user		
Casing material	Aluminium		
Motor support	Cast iron - Alluminium		
Dimensions of cable entry	PG11 PG13.5 PG16 PG21	M20x1.5 M25x1.5 M32x1.5	
Flange mount (IEC motor)	/	IM B5 (up to 1.5 kW) IM B35 (2.2 kW and above)	IM B3

PERFORMANCE RANGE

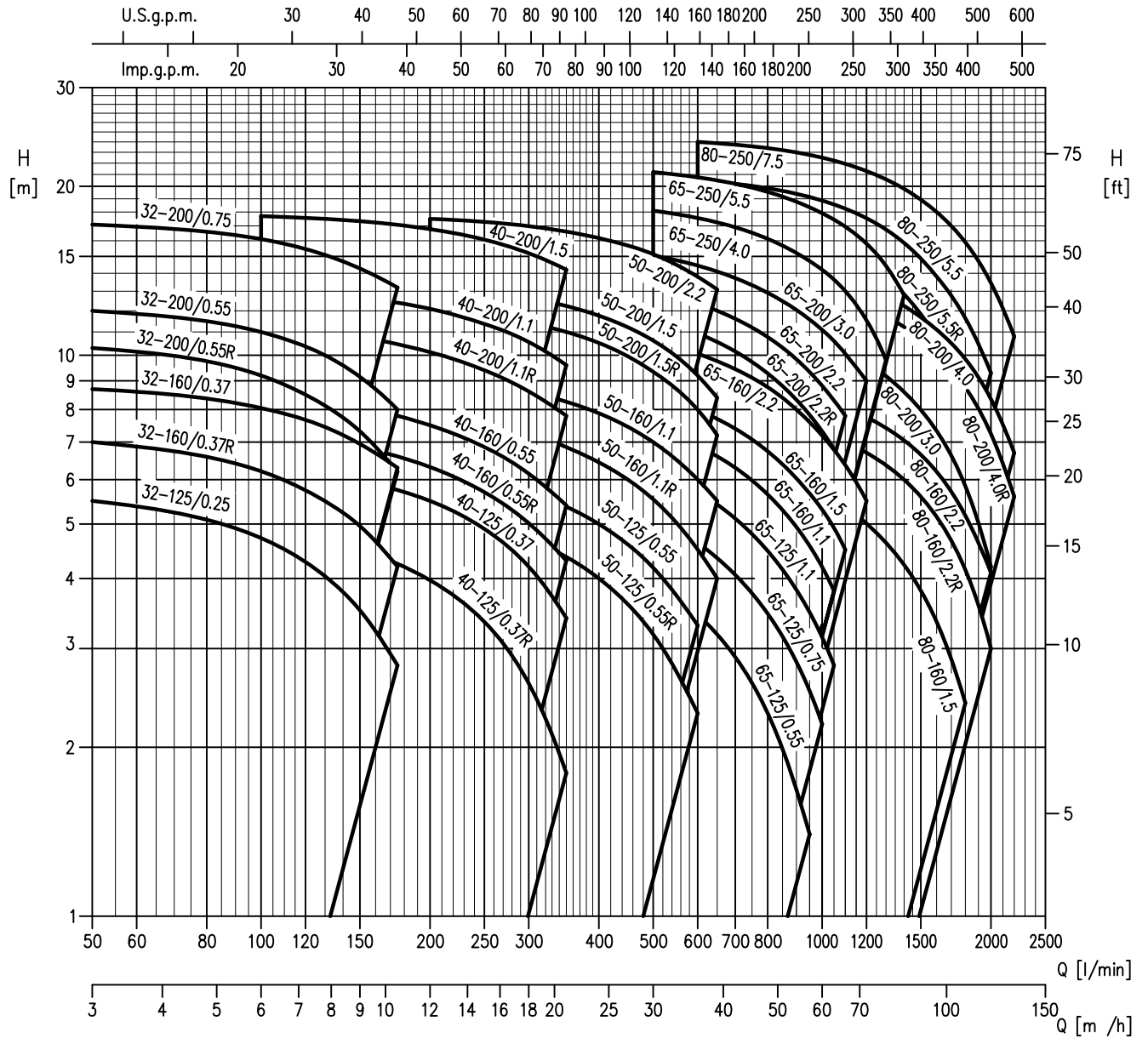

SELECTION CHART

50Hz

Rev. L

SELECTION CHART

3 SERIES 4 Poles: 32, 40, 50 Version

Pump type	Power		Q=Capacity													
	[kW]	[HP]	l/min	0	50	100	150	175	200	250	300	350	400	500	600	650
			m ³ /h	0	3	6	9	10.5	12	15	18	21	24	30	36	39
H=Total manometric head in meters																
32-125/0.25	0.25	0.33	5.7	5.5	4.7	3.5	2.8	-	-	-	-	-	-	-	-	-
32-160/0.37R	0.37	0.5	7.3	7	6.2	5	4.2	-	-	-	-	-	-	-	-	-
32-160/0.37	0.37	0.5	9	8.7	8.1	7	6.3	-	-	-	-	-	-	-	-	-
32-200/0.55R	0.55	0.75	10.8	10.3	9.2	7.3	6.2	-	-	-	-	-	-	-	-	-
32-200/0.55	0.55	0.75	12.5	12	11	9.2	8	-	-	-	-	-	-	-	-	-
32-200/0.75	0.75	1	17.5	17.1	16.1	14.3	13.2	-	-	-	-	-	-	-	-	-
40-125/0.37R	0.37	0.5	5.1	-	4.8	4.5	4.3	4	3.4	2.6	1.8	-	-	-	-	-
40-125/0.37	0.37	0.5	6.5	-	6.3	6	5.8	5.5	4.9	4.2	3.4	-	-	-	-	-
40-160/0.55R	0.55	0.75	7.7	-	7.3	6.9	6.6	6.3	5.7	5	4.3	-	-	-	-	-
40-160/0.55	0.55	0.75	9.1	-	8.6	8.1	7.8	7.5	6.9	6.2	5.4	-	-	-	-	-
40-200/1.1R	1.1	1.5	11.6	-	11.2	10.8	10.5	10.1	9.4	8.6	7.8	-	-	-	-	-
40-200/1.1	1.1	1.5	13.6	-	13.2	12.7	12.4	12.1	11.4	10.6	9.6	-	-	-	-	-
40-200/1.5	1.5	2	18	-	17.7	17.3	17.1	16.8	16.1	15.2	14.2	-	-	-	-	-
50-125/0.55R	0.55	0.75	5.4	-	-	-	-	5.2	5	4.7	4.4	4	3.2	2.3	-	-
50-125/0.55	0.55	0.75	6.4	-	-	-	-	6.2	6	5.7	5.4	5	4.2	3.3	-	-
50-160/1.1R	1.1	1.5	8.2	-	-	-	-	7.8	7.6	7.2	6.9	6.4	5.5	4.5	4	-
50-160/1.1	1.1	1.5	9.5	-	-	-	-	9.1	8.9	8.6	8.3	7.9	7	6	5.5	-
50-200/1.5R	1.5	2	12.7	-	-	-	-	12.1	11.8	11.4	11	10.5	9.3	8	7.2	-
50-200/1.5	1.5	2	14	-	-	-	-	13.3	13	12.7	12.2	11.8	10.6	9.2	8.4	-
50-200/2.2	2.2	3	17.8	-	-	-	-	17.5	17.3	17	16.6	16.2	15.1	13.8	13.1	-

3 SERIES 4 Poles: 65, 80 Version

Pump type	Power		Q=Capacity																		
	[kW]	[HP]	l/min	0	300	350	500	600	800	950	1000	1050	1100	1200	1300	1400	1600	1800	2000	2200	
			m ³ /h	0	18	21	30	36	48	57	60	63	66	72	78	84	96	108	120	132	
H=Total manometric head in meters																					
65-125/0.55	0.55	0.75	5.3	4.8	4.6	4	3.5	2.3	1.4	-	-	-	-	-	-	-	-	-	-	-	
65-125/0.75	0.75	1	6.4	6	5.8	5.2	4.6	3.5	2.5	2.2	-	-	-	-	-	-	-	-	-	-	
65-125/1.1	1.1	1.5	7.7	7.2	7	6.3	5.7	4.5	3.5	3.2	2.8	-	-	-	-	-	-	-	-	-	
65-160/1.1	1.1	1.5	8.6	-	8.1	7.4	6.9	5.7	4.6	4.2	3.8	-	-	-	-	-	-	-	-	-	
65-160/1.5	1.5	2	9.7	-	9.2	8.5	8	6.7	5.7	5.3	4.9	4.5	-	-	-	-	-	-	-	-	
65-160/2.2	2.2	3	11.8	-	11.3	10.6	10.1	8.8	7.6	7.2	6.8	6.4	5.5	-	-	-	-	-	-	-	
65-200/2.2R	2.2	3	13	-	12.4	11.6	10.9	9.3	7.8	7.3	6.8	-	-	-	-	-	-	-	-	-	
65-200/2.2	2.2	3	14.5	-	13.9	13	12.4	10.8	9.3	8.8	8.3	7.8	-	-	-	-	-	-	-	-	
65-200/3	3	4	16.3	-	15.8	15.1	14.4	12.9	11.6	11.1	10.6	10.1	9	-	-	-	-	-	-	-	
65-250/4	4	5.5	18.8	-	-	18.1	17.6	16.1	14.7	14.2	13.7	13	11.6	9.8	-	-	-	-	-	-	
65-250/5.5	5.5	7.5	21.8	-	-	21.2	20.8	19.6	18.4	17.9	17.5	17	15.8	14.4	12.8	-	-	-	-	-	
80-160/1.5	1.5	2	7.3	-	-	-	6.8	6.3	5.9	5.7	5.6	5.4	5	4.6	4.2	3.4	2.4	-	-	-	
80-160/2.2R	2.2	3	8.6	-	-	-	8.1	7.8	7.4	7.3	7.1	7	6.7	6.4	6	5.2	4.2	3	-	-	
80-160/2.2	2.2	3	9.5	-	-	-	9.1	8.8	8.4	8.3	8.2	8	7.8	7.4	7.1	6.2	5.2	4.1	-	-	
80-200/3	3	4	12.4	-	-	-	12	11.5	10.9	10.7	10.4	10.2	9.7	9.2	8.6	7.3	5.9	4.2	-	-	
80-200/4R	4	5.5	14.8	-	-	-	14.4	13.9	13.4	13.2	12.9	12.7	12.2	11.7	11.2	10.1	8.8	7.2	5.6	-	
80-200/4	4	5.5	16.0	-	-	-	15.4	14.9	14.3	14.1	13.9	13.7	13.2	12.8	12.3	11.1	9.9	8.4	6.7	-	
80-250/5.5R	5.5	7.5	18.5	-	-	-	17.7	17	16.3	16	15.7	15.4	14.6	13.8	12.9	10.7	8.4	-	-	-	
80-250/5.5	5.5	7.5	21.2	-	-	-	20.5	19.9	19.1	18.9	18.6	18.2	17.6	16.8	15.9	13.8	11.7	9.3	-	-	
80-250/7.5	7.5	10	24.5	-	-	-	24	23.4	22.8	22.5	22.2	21.9	21.3	20.6	19.8	18	15.9	13.5	10.8	-	

TYPE KEY AND CURVE SPECIFICATIONS

50Hz

Rev. L

TYPE KEY

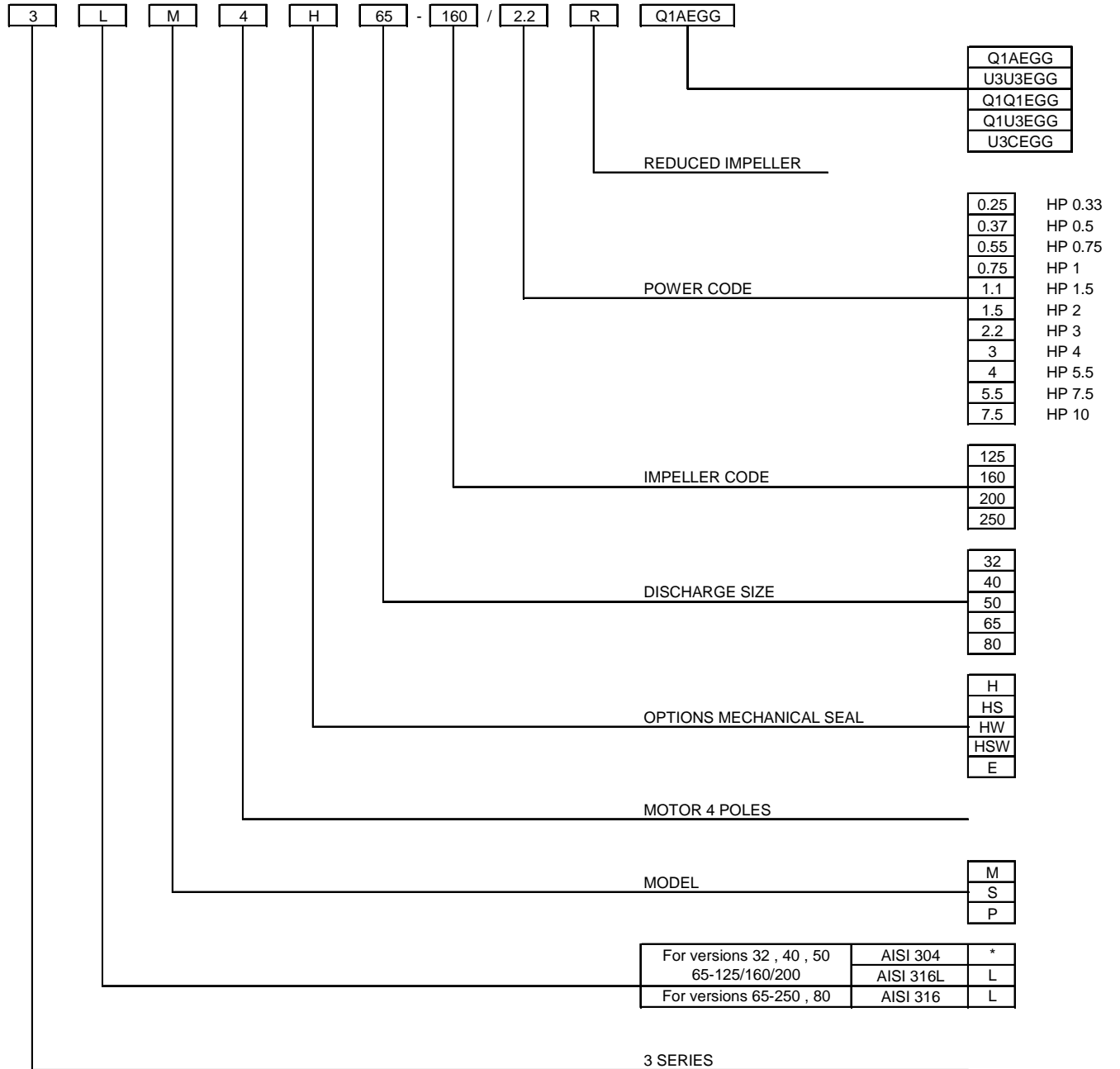

(*) No indication

PERFORMANCE CURVE SPECIFICATIONS

The specifications below qualify the curves shown on the following pages.

Tolerances according to ISO 9906:2012 - Grade 3B

The curves refer to effective speed of asynchronous motors at 50 Hz, 4 poles.

Measurements were carried out with clean water at 20°C of temperature and with a kinematic viscosity of $\nu = 1 \text{ mm}^2/\text{s}$ (1 cSt)

The NPSH curve is an average curve obtained in the same conditions of performance curves.

The continuous curves indicate the recommended working range. The dotted curve is only a guide.

In order to avoid the risk of over-heating, the pumps should not be used at a flow rate below 10% of best efficiency point.

Symbols explanation:

- Q = volume flow rate
- H = total head
- P_2 = pump power input (shaft power)
- η = pump efficiency
- NPSH = net positive suction head required by the pump
- MEI = minimum efficiency index

MEI INDEX SPECIFICATION

The minimum efficiency index (MEI) is a measure of the quality of a pump size in respect to its mean efficiency. The minimum efficiency index is based on the hydraulic efficiency and on the head at the best efficiency point.

The efficiency of a pump with trimmed impeller is usually lower than that of a pump with the full impeller diameter. The trimming of the impeller will adapt the pump to a fixed duty point, leading to a reduced energy consumption. The minimum efficiency index (MEI) is based on the full impeller diameter.

The operation of these water pumps with variable duty points may be more efficient and economical when controlled, for example, by the use of a variable speed drive that matches the pump duty to the system.

MEI=0.4 for ESCC 1450rpm

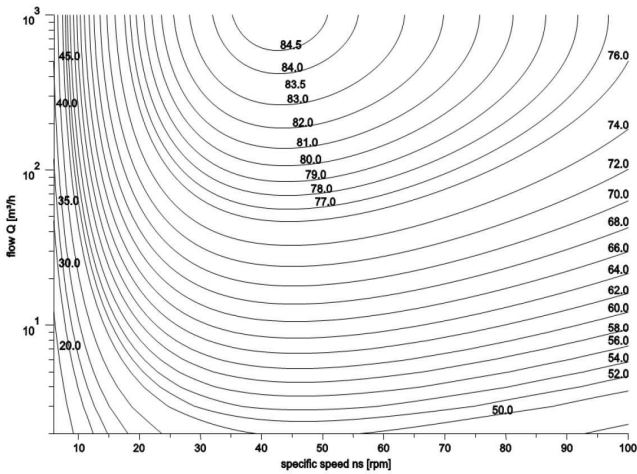

MEI = 0.7 for ESCC 1450rpm

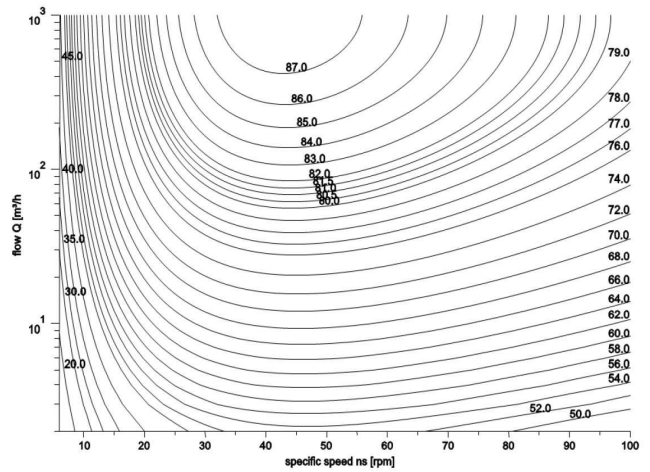

MEI = 0.4 for ESOB 1450

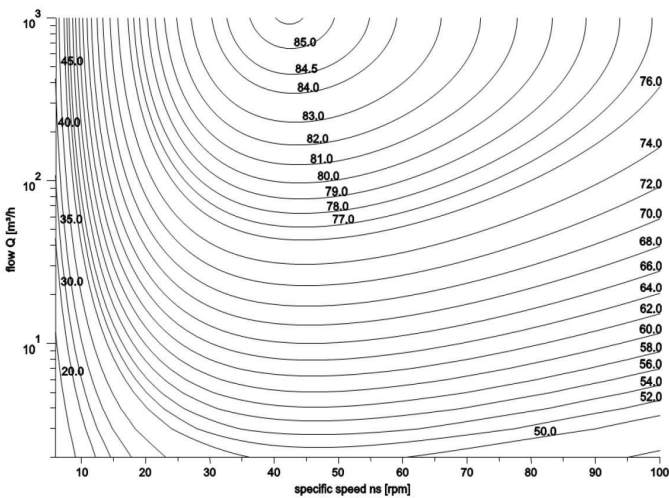

MEI = 0.7 for ESOB 1450 rpm

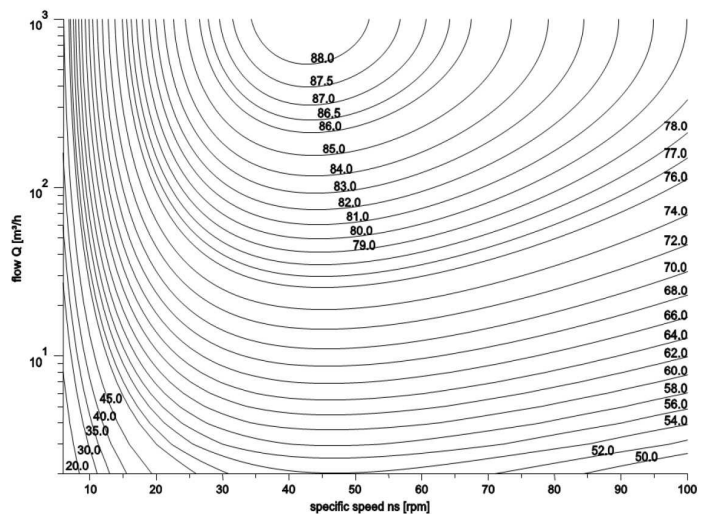

32-125/0.25 (0.25 kW) MEI > 0.50 – impeller diameter = 133 mm

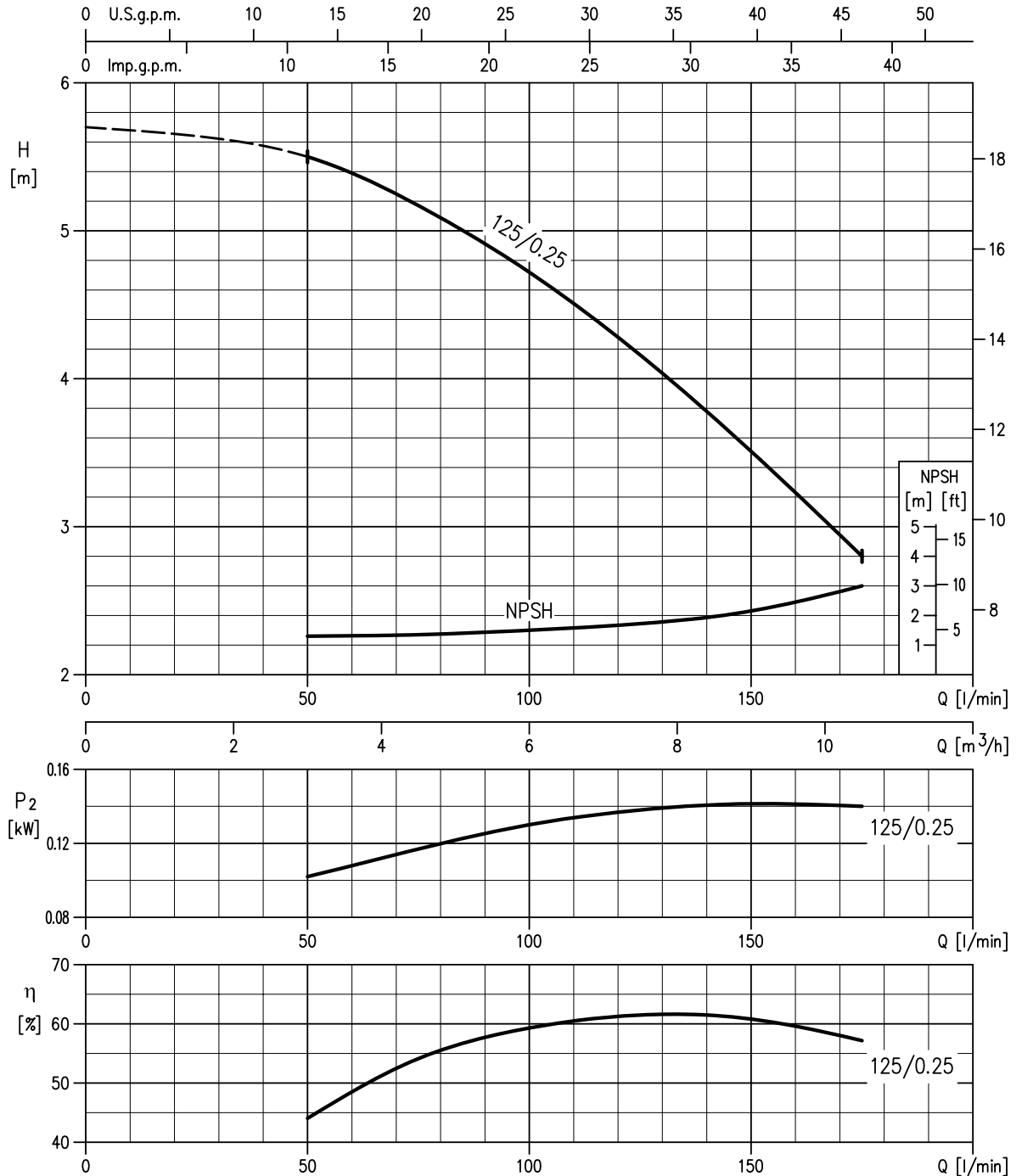

Rotation speed ≈ 1400 min⁻¹
 Test standard: ISO 9906:2012 – Grade 3B

32-160/0.37R (0.37kW) MEI > 0.70 – impeller diameter = 151 mm
32-160/0.37 (0.37kW) MEI > 0.70 – impeller diameter = 166 mm

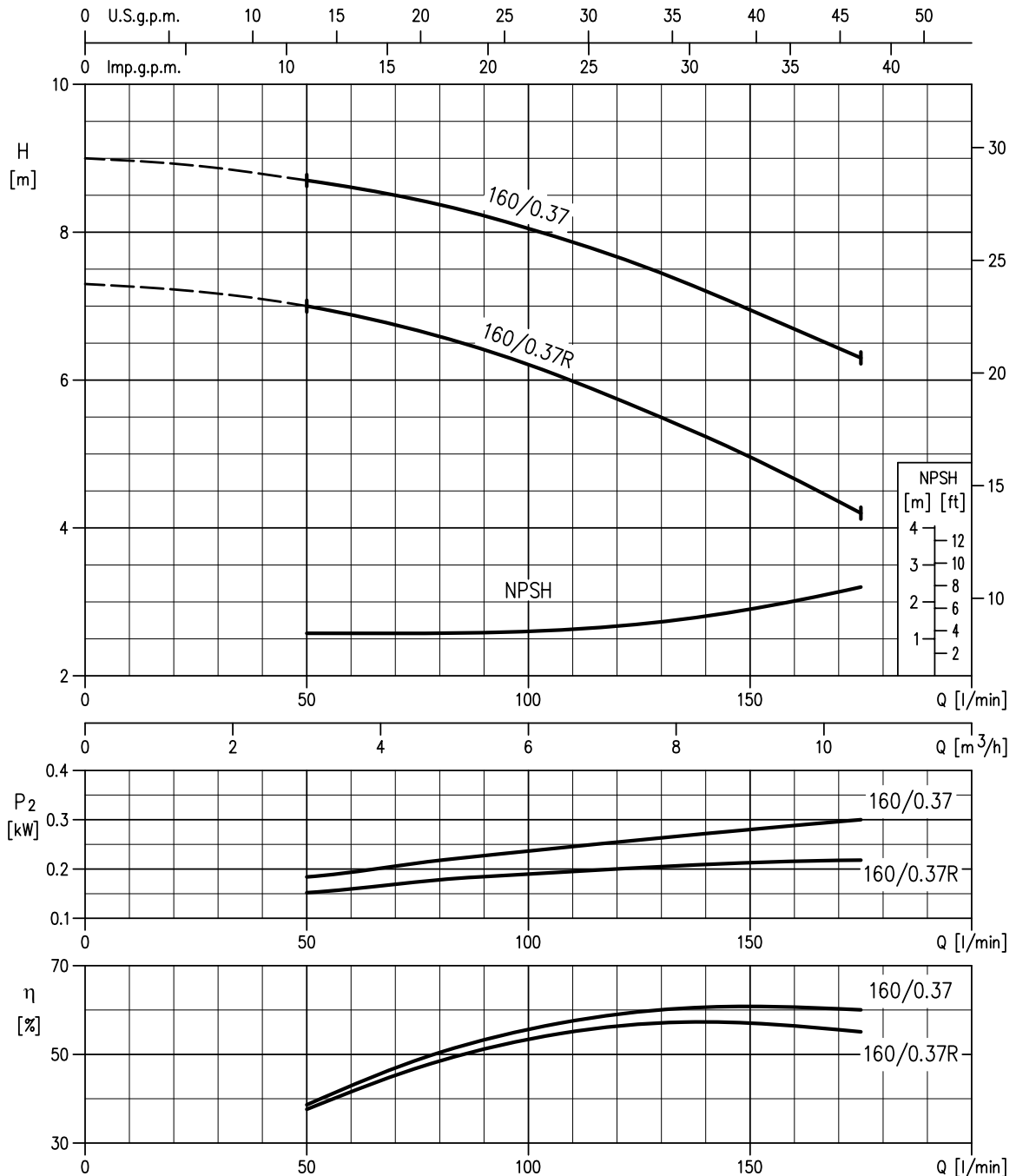

Rotation speed ≈ 1400 min⁻¹
 Test standard: ISO 9906:2012 – Grade 3B

32-200/0.55R (0.55 kW) MEI > 0.70 – impeller diameter = 186 mm
 32-200/0.55 (0.55kW) MEI > 0.70 – impeller diameter = 200 mm
 32-200/0.75 (0.55kW) MEI > 0.70 – impeller diameter = 224 mm

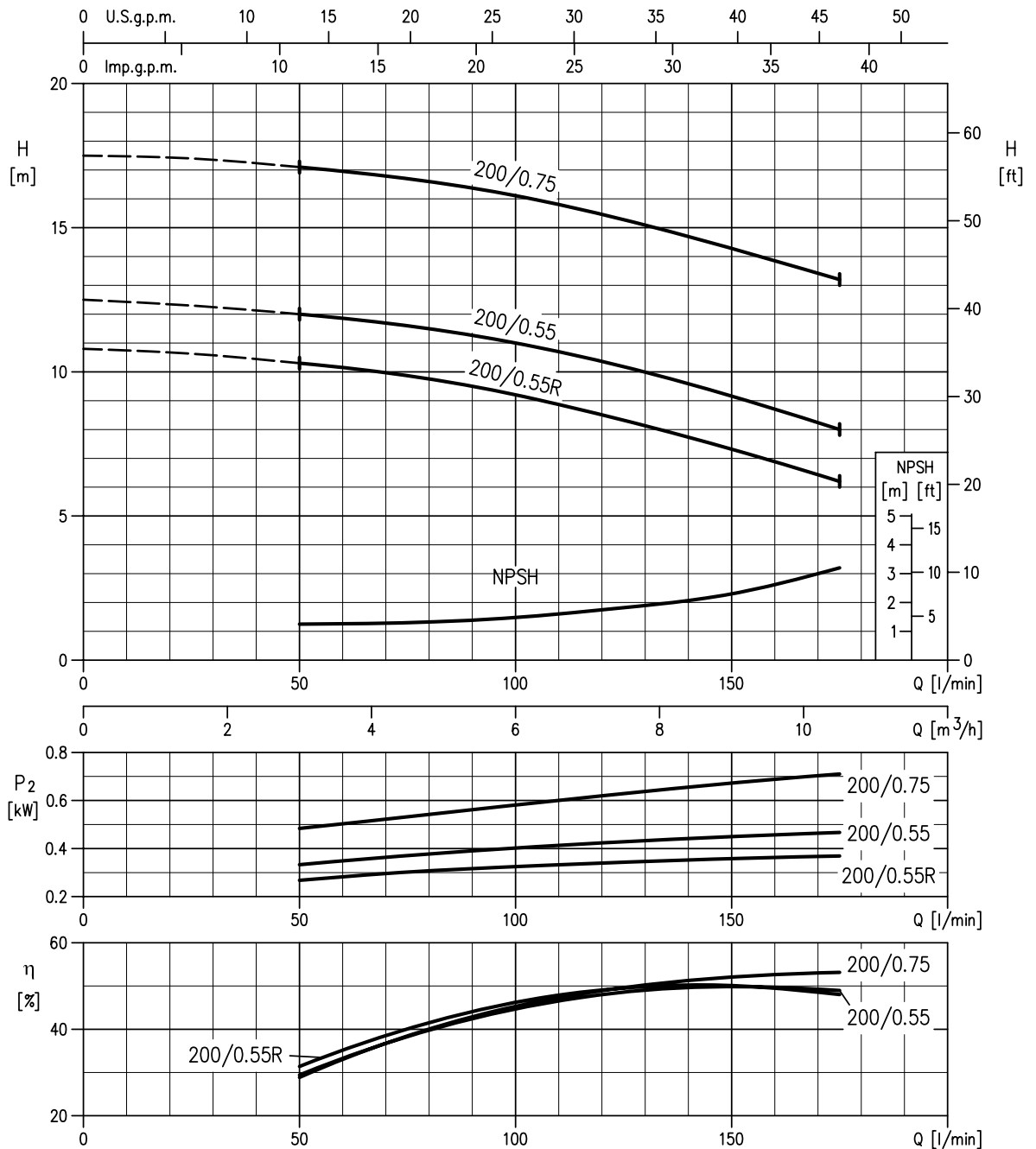

Rotation speed ≈ 1400 min⁻¹
 Test standard: ISO 9906:2012 – Grade 3B

40-125/0.37R (0.37 kW) MEI > 0.70 – impeller diameter = 125 mm
40-125/0.37 (0.37 kW) MEI > 0.70 – impeller diameter = 140 mm

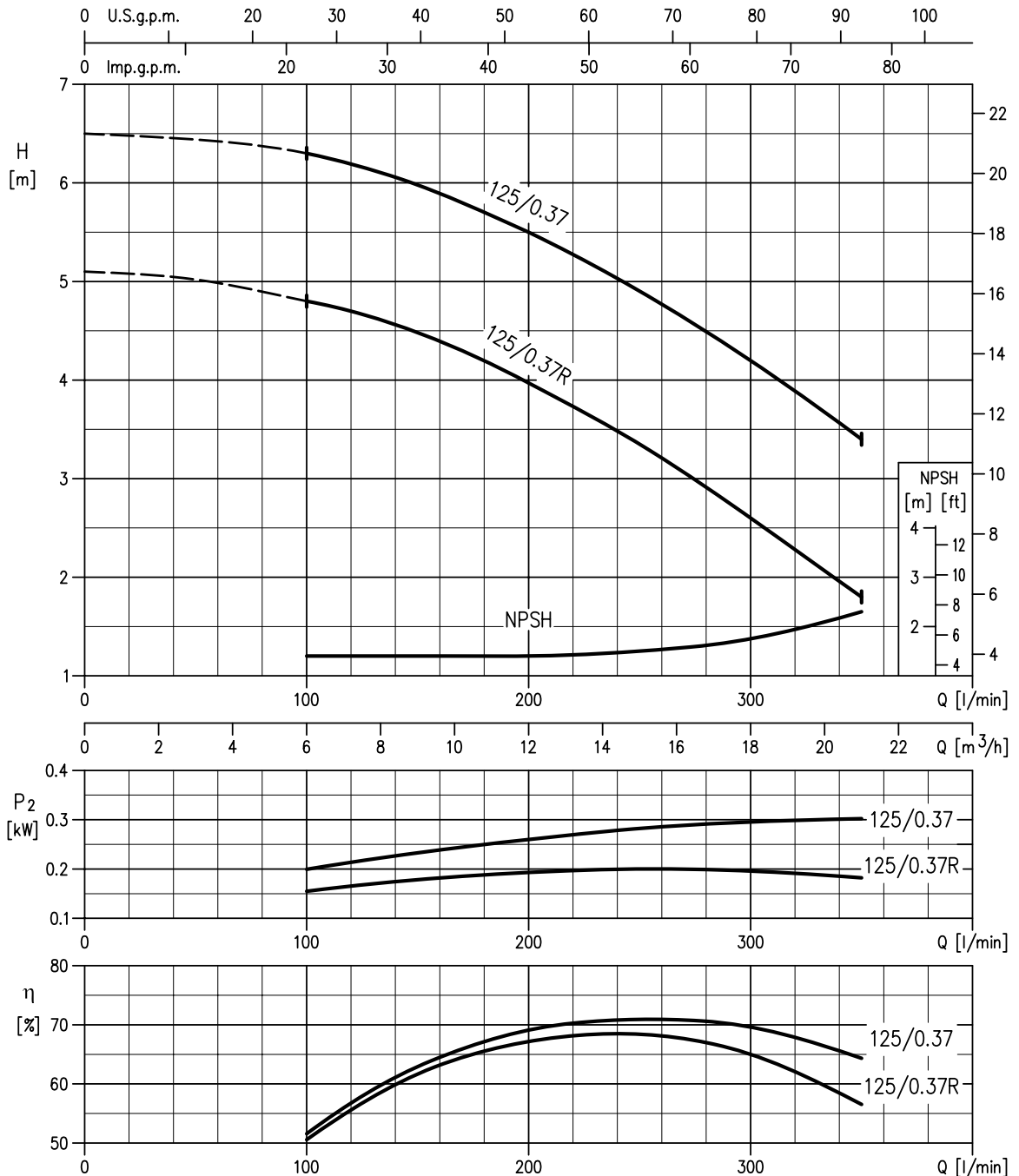

Rotation speed ≈ 1400 min⁻¹
 Test standard: ISO 9906:2012 – Grade 3B

40-160/0.55R (0.55 kW) MEI > 0.40 – impeller diameter = 151 mm
 40-160/0.55 (0.55 kW) MEI > 0.40 – impeller diameter = 166 mm

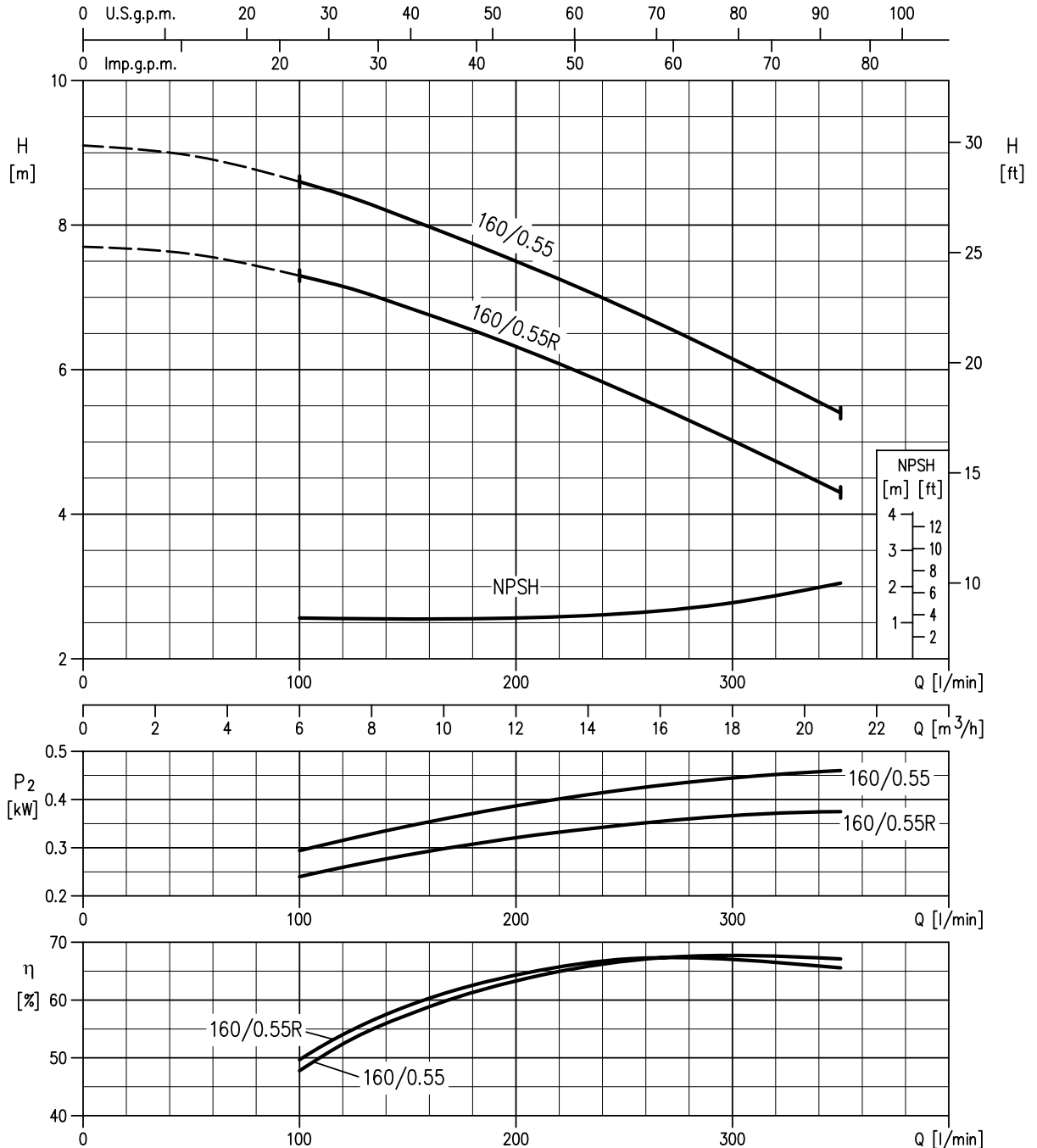

Rotation speed ≈ 1400 min⁻¹
 Test standard: ISO 9906:2012 – Grade 3B

40-200/1.1R (1.1 kW) MEI > 0.70 – impeller diameter = 183 mm
 40-200/1.1 (1.1 kW) MEI > 0.70 – impeller diameter = 200 mm
 40-200/1.5 (1.5 kW) MEI > 0.70 – impeller diameter = 224 mm

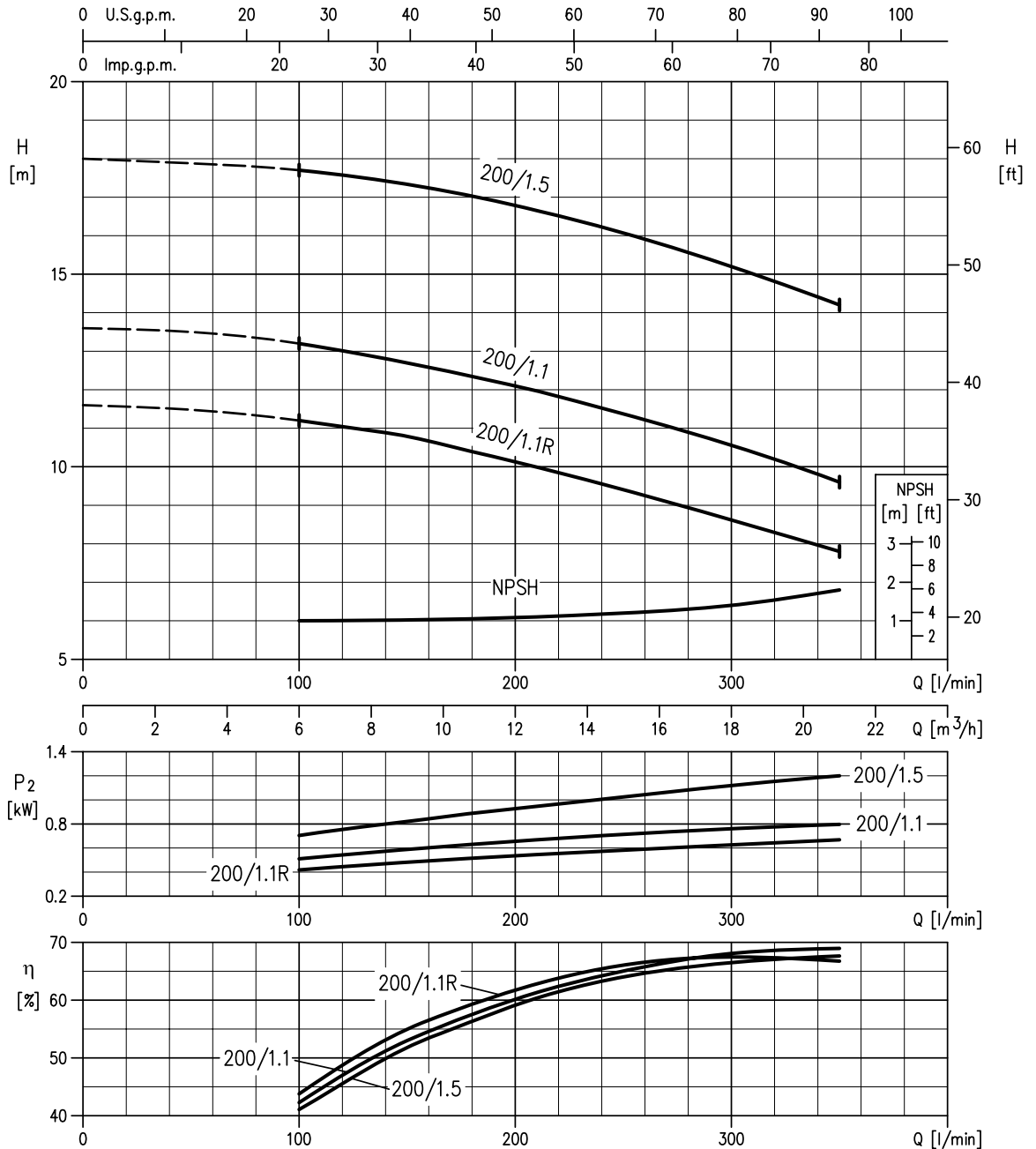

Rotation speed ≈ 1400 min⁻¹
 Test standard: ISO 9906:2012 – Grade 3B

50-125/0.55R (0.55 kW) MEI > 0.40 – impeller diameter = 131 mm
 50-125/0.55 (0.55 kW) MEI > 0.40 – impeller diameter = 140 mm

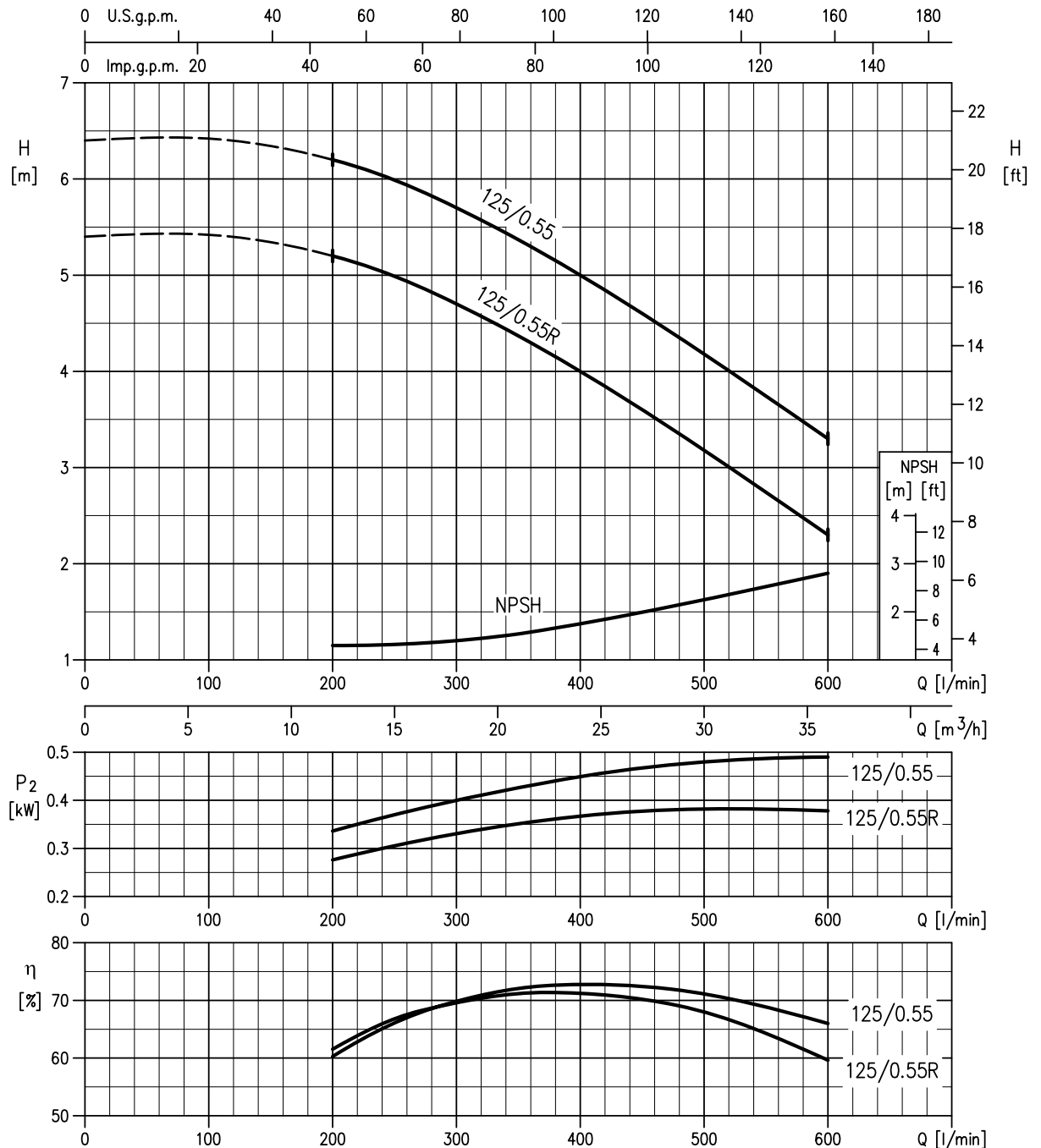

Rotation speed ≈ 1400 min⁻¹
 Test standard: ISO 9906:2012 – Grade 3B

50-160/1.1R (1.1 kW) MEI > 0.60 – impeller diameter = 154 mm
 50-160/1.1 (1.1 kW) MEI > 0.60 – impeller diameter = 166 mm

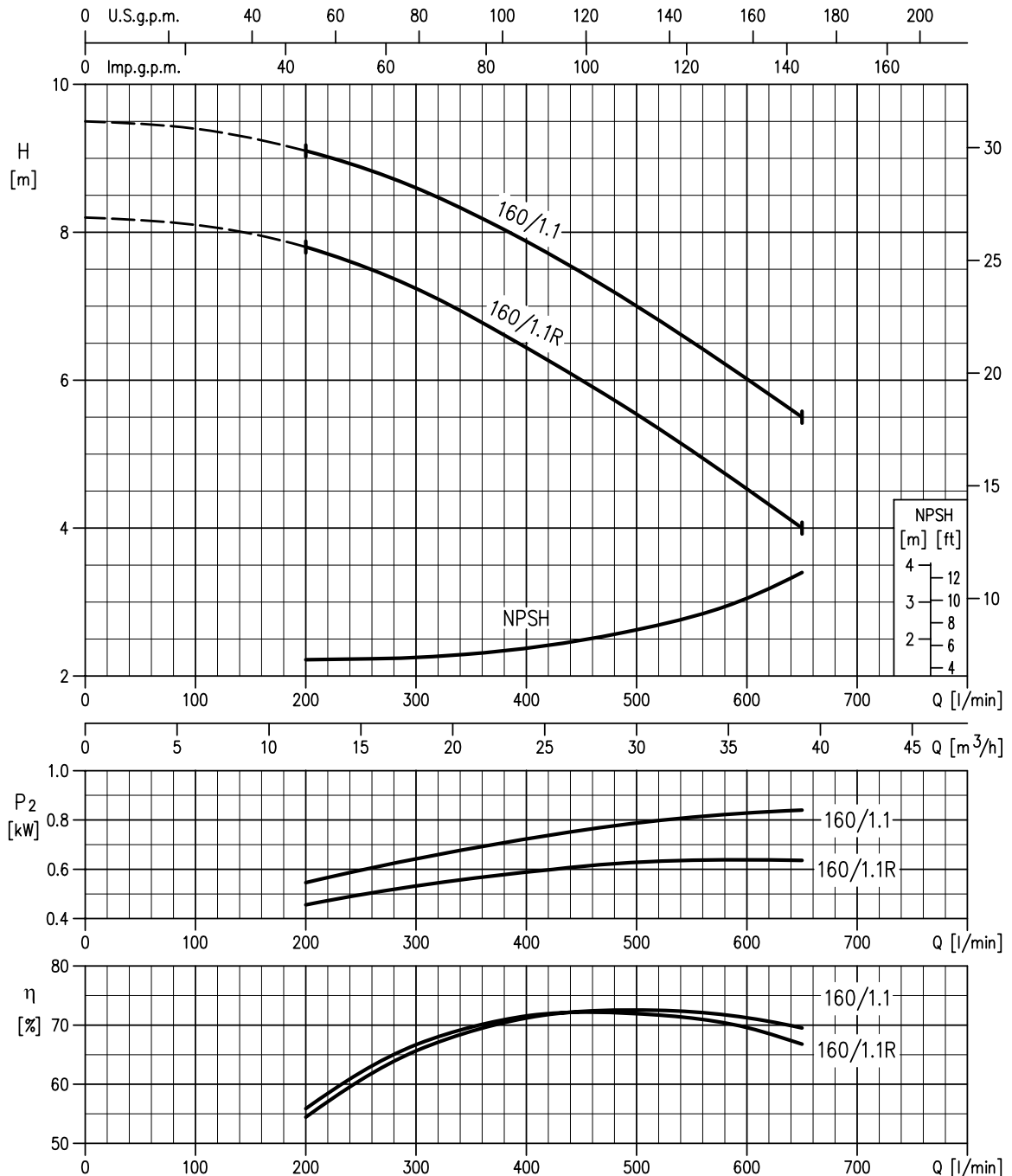

Rotation speed ≈ 1400 min⁻¹
 Test standard: ISO 9906:2012 – Grade 3B

50-200/1.5R (1.5 kW) MEI > 0.60 – impeller diameter = 191 mm
 50-200/1.5 (1.5 kW) MEI > 0.60 – impeller diameter = 200 mm
 50-200/2.2 (2.2 kW) MEI > 0.60 – impeller diameter = 224 mm

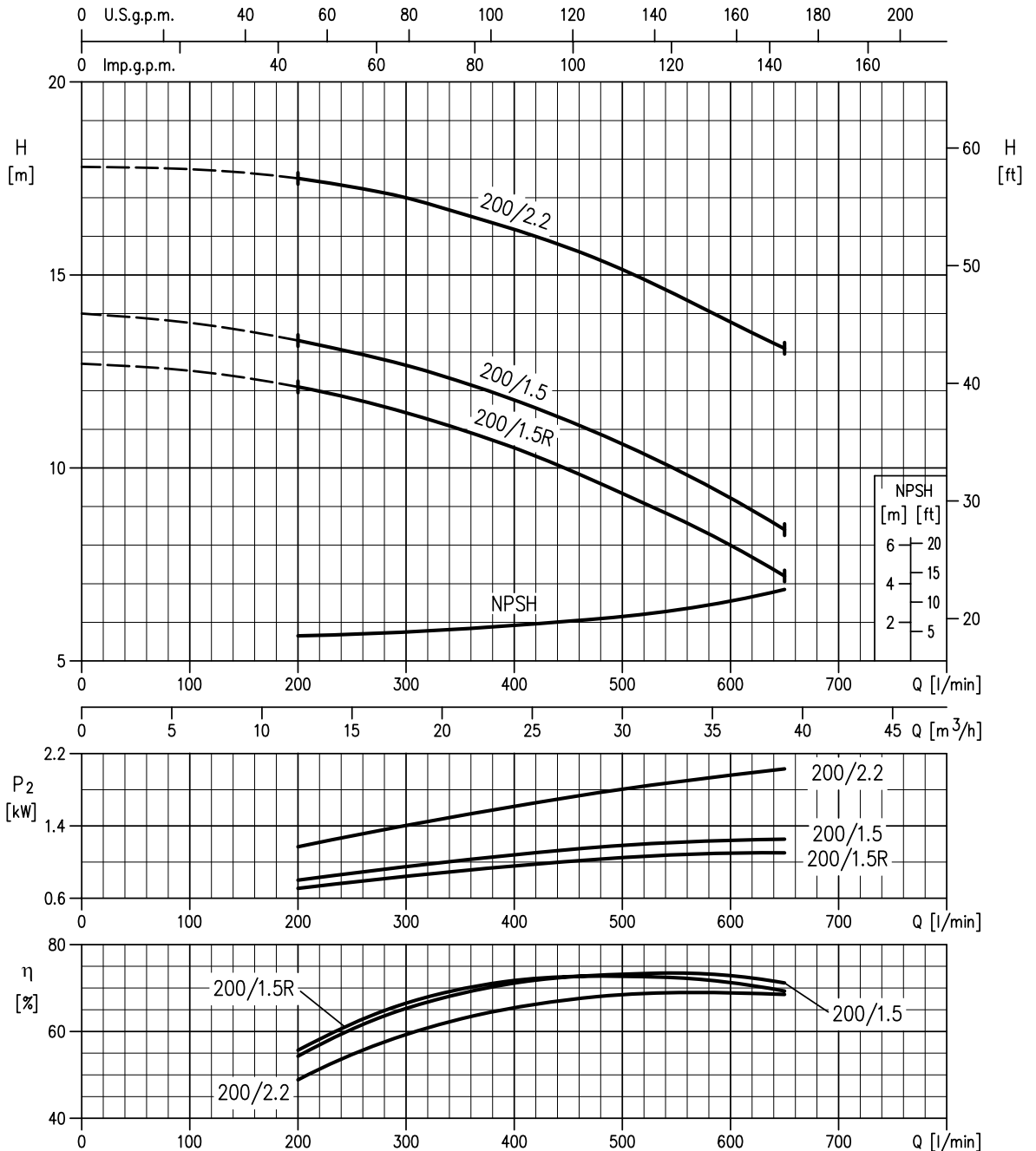

Rotation speed ≈ 1400 min⁻¹
 Test standard: ISO 9906:2012 – Grade 3B

65-125/0.55 (0.55 kW) MEI > 0.50 – impeller diameter = 128 mm
 65-125/0.75 (0.75 kW) MEI > 0.50 – impeller diameter = 138 mm
 65-125/1.1 (1.1 kW) MEI > 0.50 – impeller diameter = 149 mm

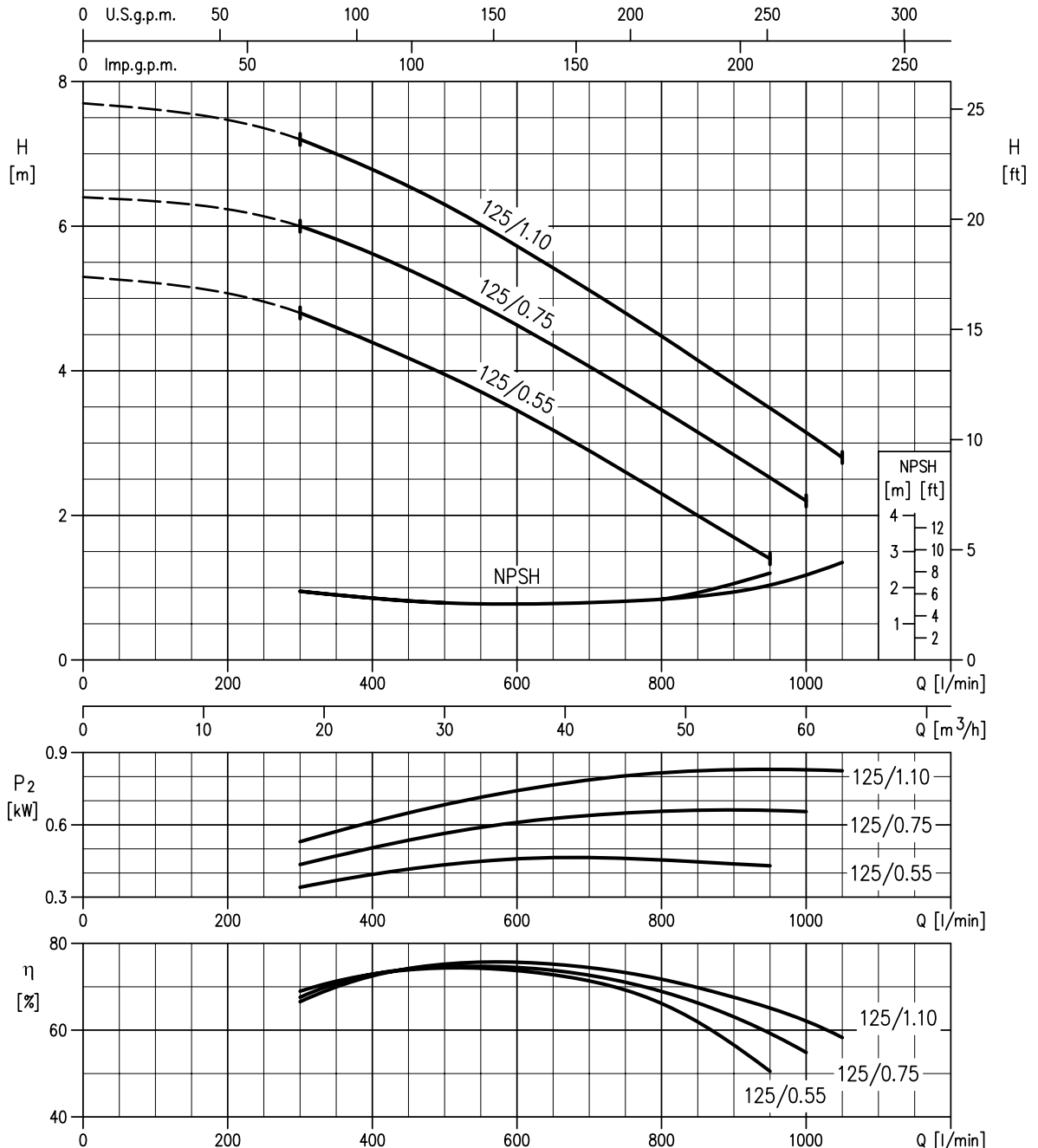

Rotation speed ≈ 1400 min⁻¹
 Test standard: ISO 9906:2012 – Grade 3B

65-160/1.1 (1.1 kW) MEI > 0.70 – impeller diameter = 161 mm
 65-160/1.5 (1.5 kW) MEI > 0.70 – impeller diameter = 168 mm
 65-160/2.2 (2.2 kW) MEI > 0.70 – impeller diameter = 178 mm

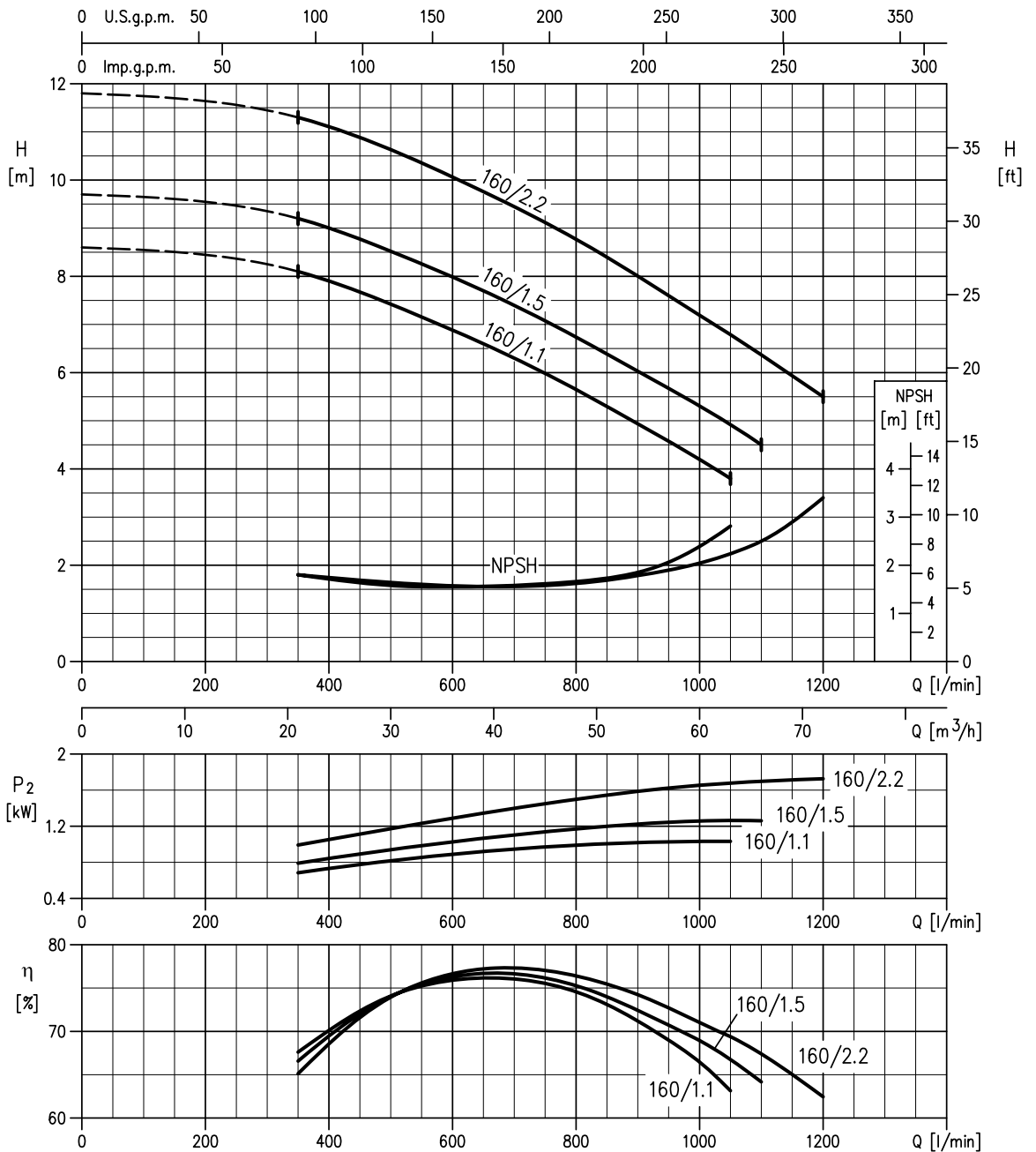

Rotation speed ≈ 1400 min⁻¹
 Test standard: ISO 9906:2012 – Grade 3B

65-200/2.2R (2.2 kW) MEI > 0.70 – impeller diameter = 190 mm
 65-200/2.2 (2.2 kW) MEI > 0.70 – impeller diameter = 201 mm
 65-200/3 (3.0 kW) MEI > 0.70 – impeller diameter = 212 mm

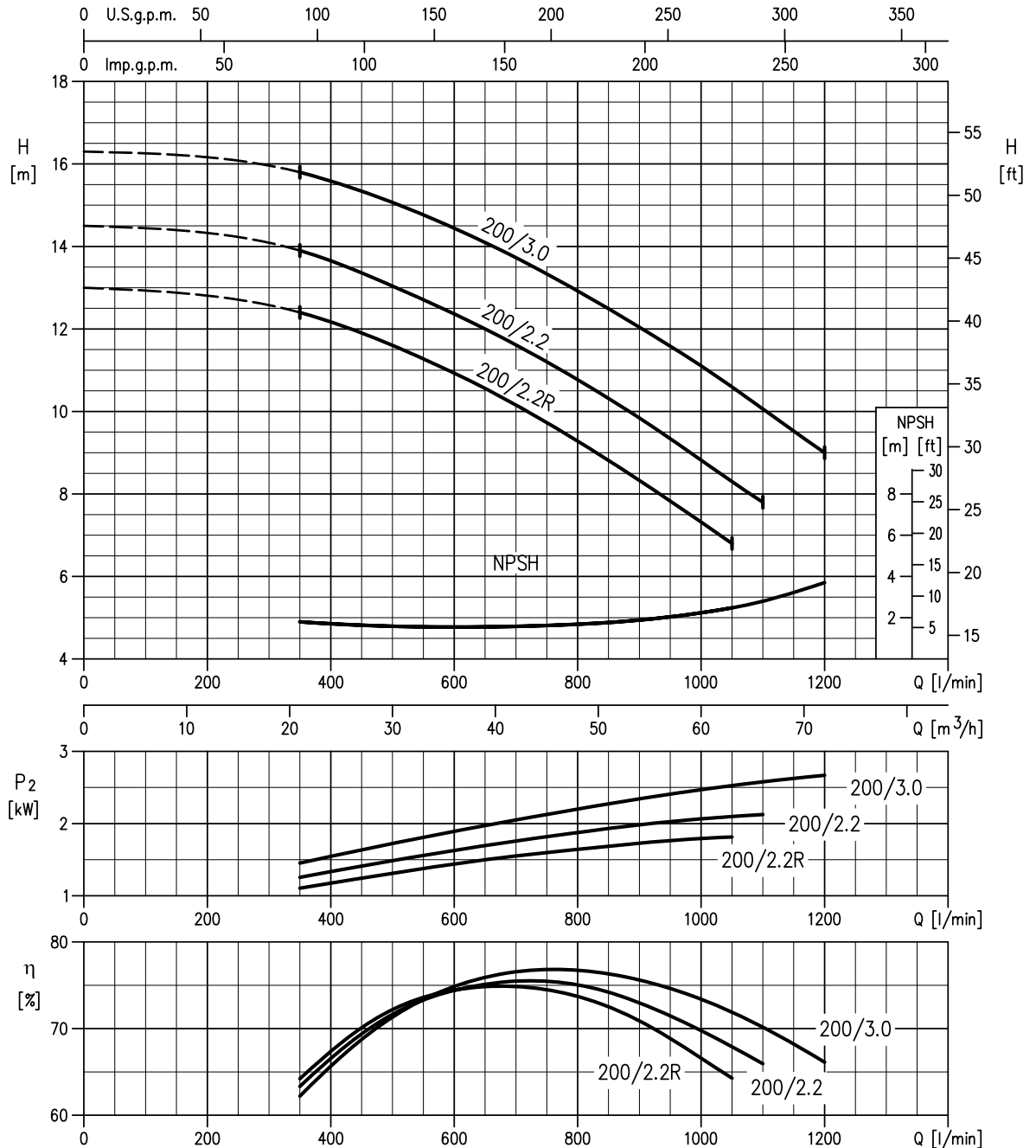

Rotation speed ≈ 1400 min⁻¹
 Test standard: ISO 9906:2012 – Grade 3B

65-250/4 (4.0 kW) MEI > 0.50 – impeller diameter = 235 mm
 65-250/5.5 (5.5 kW) MEI > 0.50 – impeller diameter = 250 mm

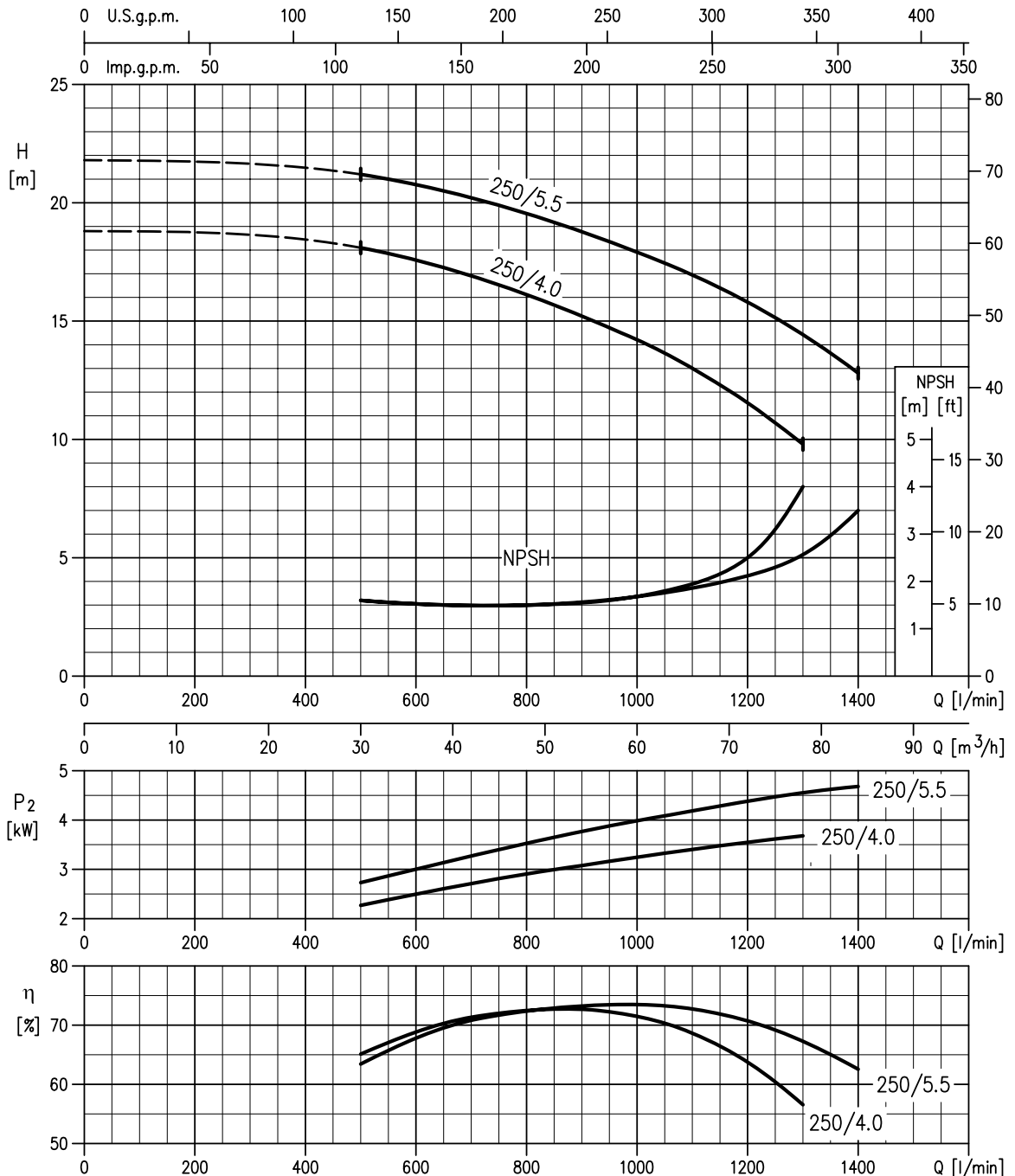

Rotation speed ≈ 1400 min⁻¹
 Test standard: ISO 9906:2012 – Grade 3B

80-160/1.5 (1.5 kW) MEI > 0.60 – impeller diameter = 156 mm
 80-160/2.2R (2.2 kW) MEI > 0.60 – impeller diameter = 165 mm
 80-160/2.2 (2.2 kW) MEI > 0.60 – impeller diameter = 174 mm

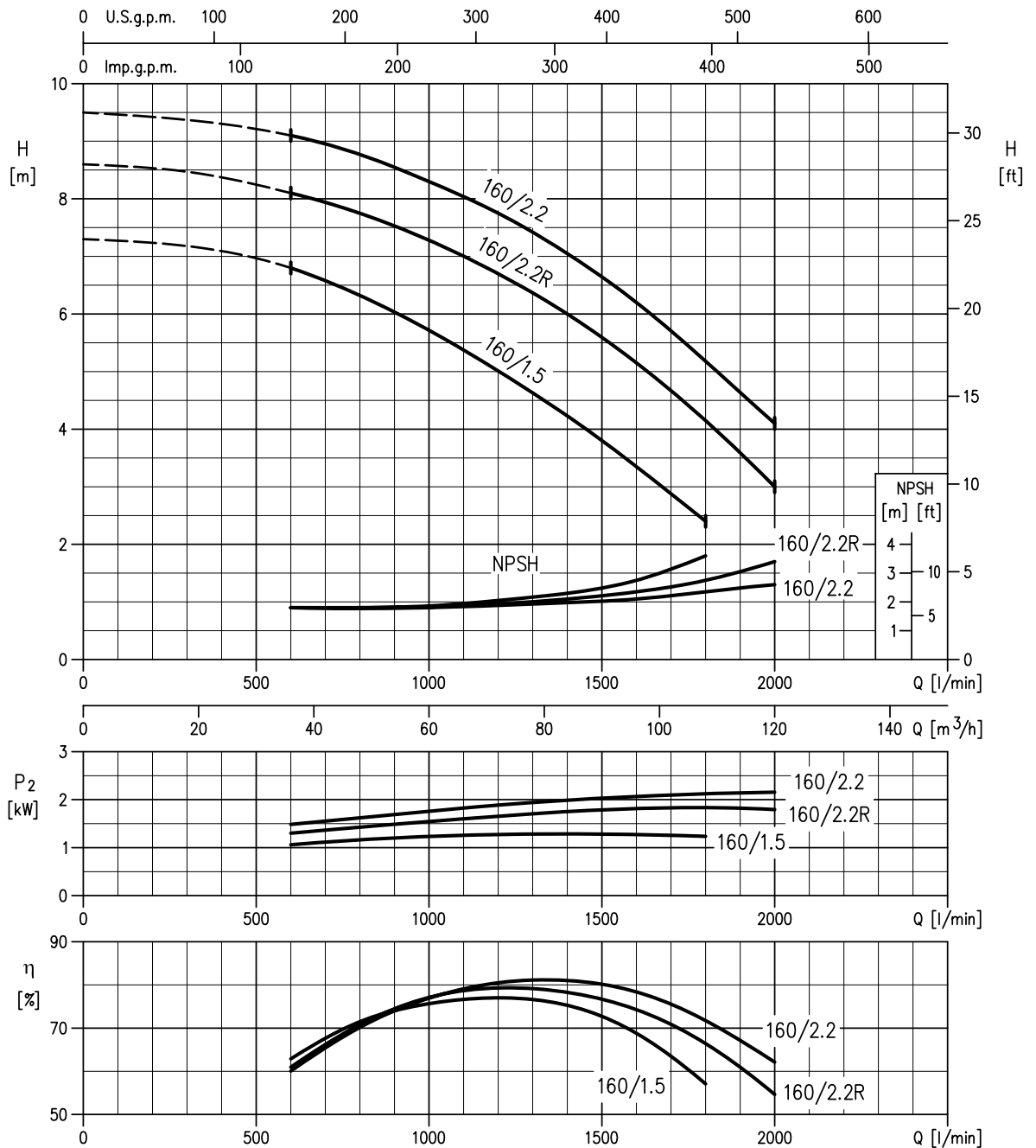

Rotation speed ≈ 1400 min⁻¹
 Test standard: ISO 9906:2012 – Grade 3B

80-200/3 (3.0 kW) MEI > 0.40 – impeller diameter = 196 mm
 80-200/4R (4.0 kW) MEI > 0.40 – impeller diameter = 211 mm
 80-200/4 (4.0 kW) MEI > 0.40 – impeller diameter = 219 mm

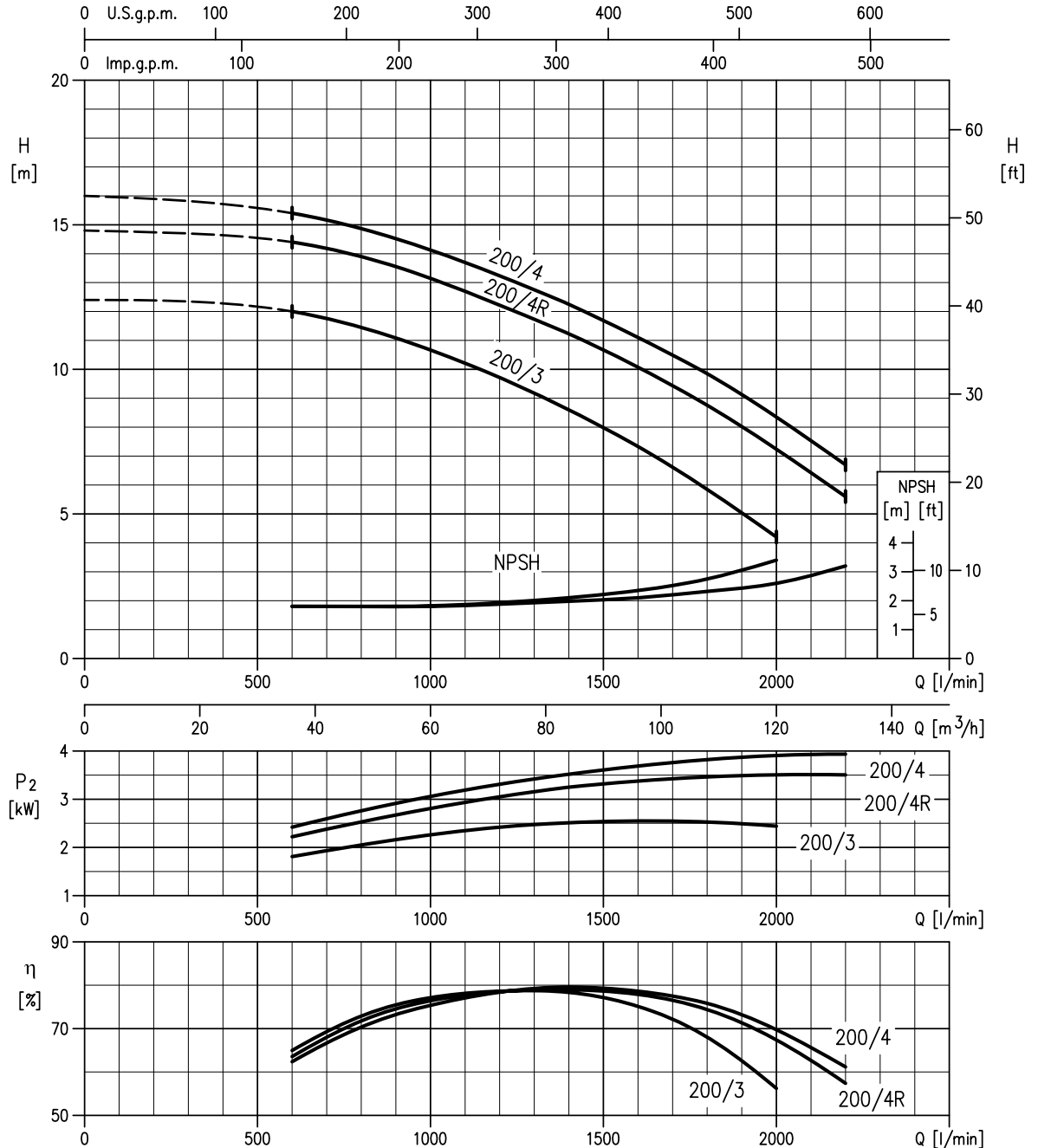

Rotation speed ≈ 1400 min⁻¹
 Test standard: ISO 9906:2012 – Grade 3B

80-250/5.5R (5.5 kW) MEI > 0.60 – impeller diameter = 230 mm
 80-250/5.5 (5.5 kW) MEI > 0.60 – impeller diameter = 246 mm
 80-250/7.5 (7.5 kW) MEI > 0.60 – impeller diameter = 263 mm

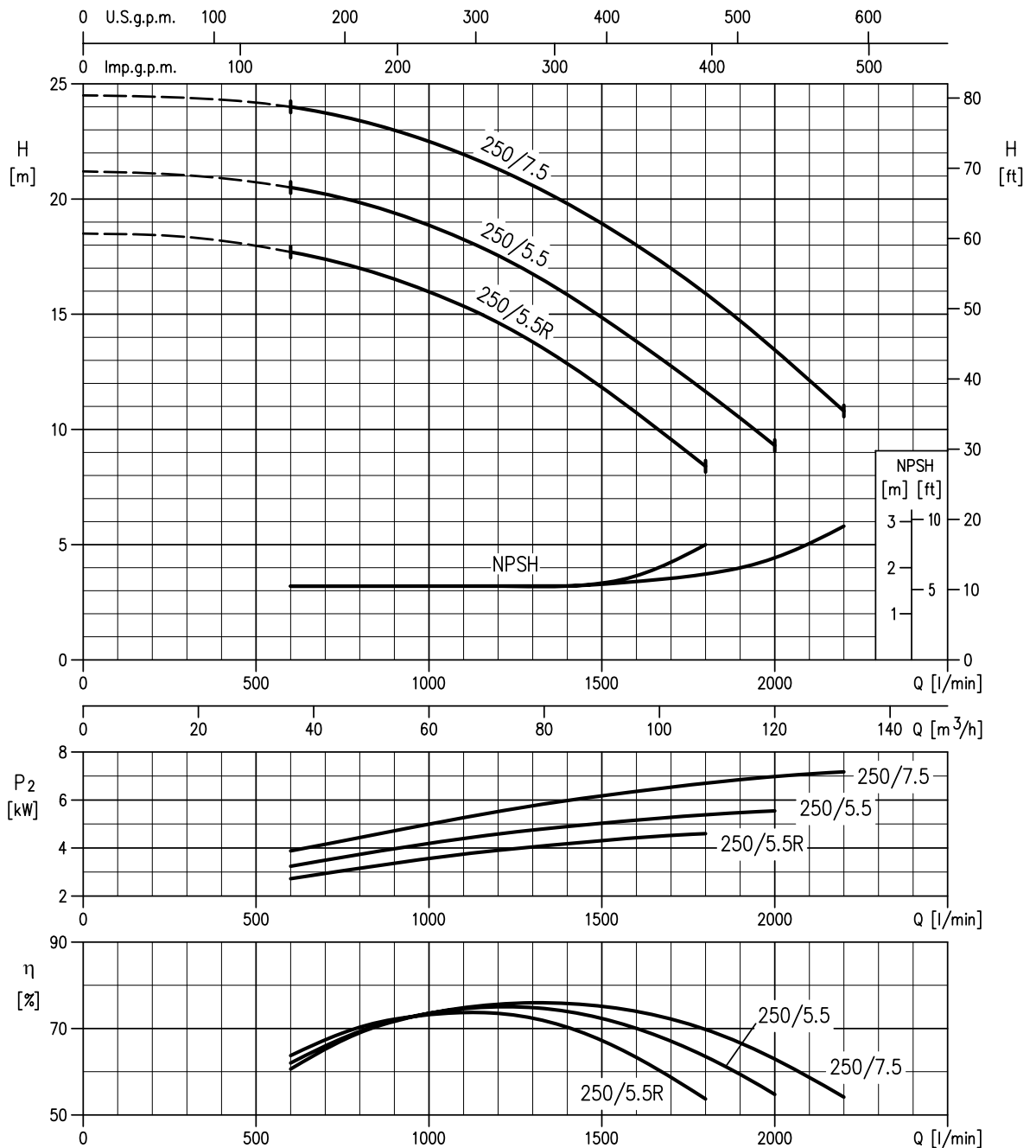

Rotation speed ≈ 1400 min⁻¹
 Test standard: ISO 9906:2012 – Grade 3B

SECTIONAL VIEW DRAWING 3(.)M4 32, 40, 50, 65-125/160/200

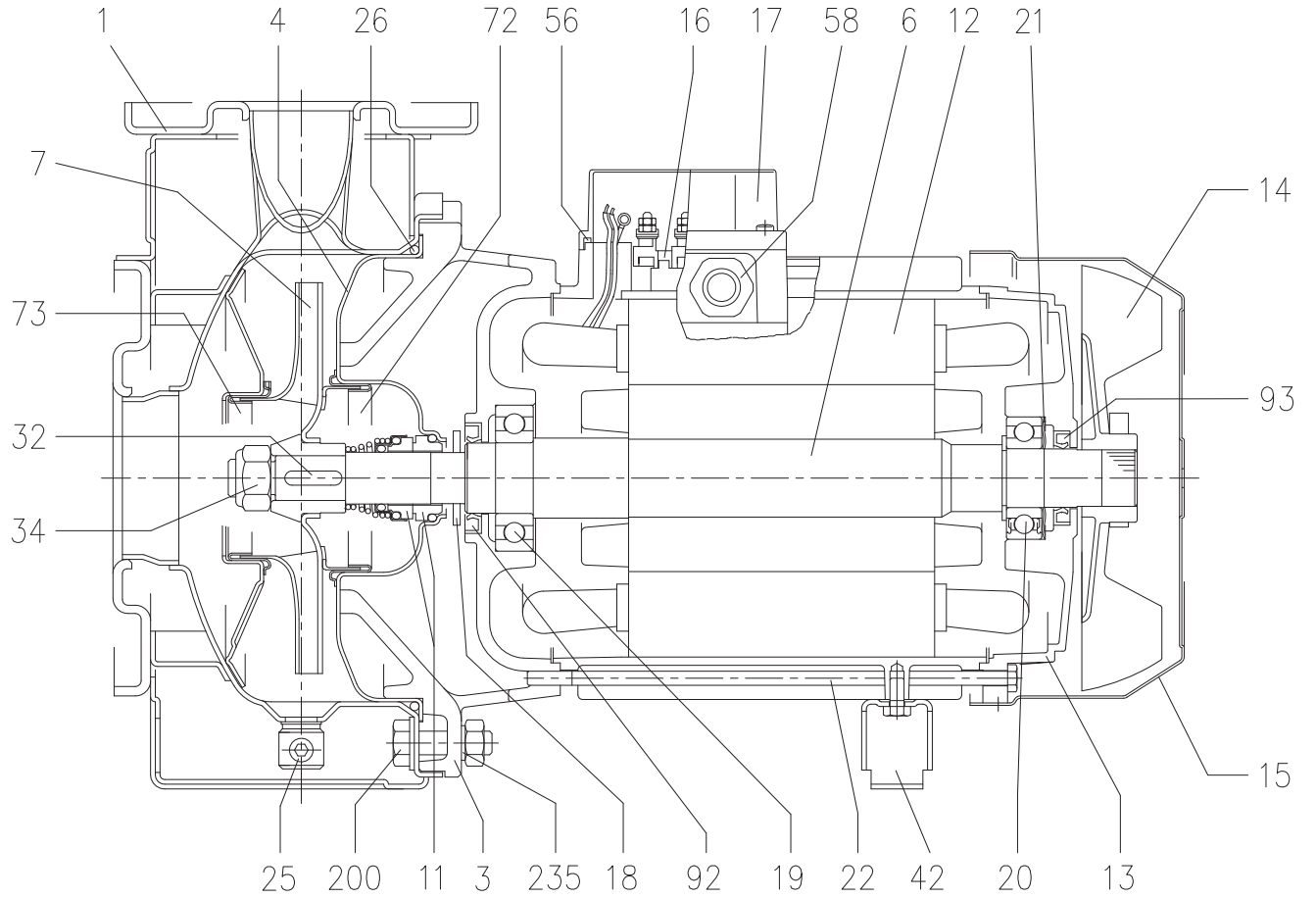

SECTIONAL VIEW TABLE 3(.JM4 32, 40, 50, 65-125/160/200

N°	PART NAME	MATERIAL		DIMENSIONS	STANDARD	Q.TY	
		3M4	3LM4				
1	Casing	EN 1.4301 (AISI 304)	EN 1.4404 (AISI 316L)			1	
3	Motor bracket	[5]				1	
4	Casing cover	EN 1.4301 (AISI 304)	EN 1.4404 (AISI 316L)			1	
6	Shaft w ith rotor-Part in contact w ith liquid	EN 1.4301 (AISI 304)	EN 1.4404 (AISI 316L)			1	
7	Impeller 32, 40, 50 65-125/160/200	EN 1.4301 (AISI 304)	EN 1.4404 (AISI 316L)			1	
11	Mechanical seal [3]	Carbon/Ceramic/NBR	SiC/SiC/FPM	See p. 321÷325		1	
12	Motor frame w ith stator	-				1	
13	Motor cover	Aluminium				1	
14	Fan	PA				1	
15	Fan cover	Fe P04 Galvanized				1	
16	Terminal	-				1	
17	Terminal box cover	Aluminium (three phase version)				1	
18	Splash ring	NBR	/	40x21.5x3	EBARA DRAWING	1	
19	Bearing	-		See table p.319		1	
20	Bearing	-		See table p.319		1	
21	Adjusting ring	Steel C70				1	
22	Tie rod	Fe 42 Galvanized		M5	EBARA DRAWING	4	
25	Draing plug	EN 1.4401 (AISI 316) / PTFE		R 1/8" L=8	DIN 906	1	
26	"O" ring	32-125, 40-125	NBR [4]	FPM	158.11x5.34	OR 6625	1
		32-160, 40-160, 50-125, 65-160			183.52x5.34	OR 6720	
		32-200, 40-200,50-160, 50-200, 65-160, 65-200			227.96x5.34	OR 6895	
32	Key	EN 1.4401 (AISI 316)		6x6x25	UNI 6604	1	
34	Impeller nut Other models 50-200/2.2	EN 1.4301 (AISI 304)	EN 1.4404 (AISI 316L)	M16x1.5 M18x1.5	UNI 7474	1	
42	Foot	Aluminium / Galvanized steel			EBARA DRAWING	1	
56	Box gasket	NBR				1	
58	Fasting nut	-				1	
72	Casing ring (not for 65 version)	EN 1.4301 (AISI 304)	EN 1.4404 (AISI 316L)			1	
73	Casing ring (not for 65 version)	EN 1.4301 (AISI 304)	EN 1.4404 (AISI 316L)			1	
92	Lip seal	Up to 1.5kW	-	-	25x40x7	DIN 3760 w ithout spring	1
		From 2.2kW to 3kW			30x47X7		
93	Lip seal	For 0.25kW	-	-	15x30x5	DIN 3760 w ithout spring	1
		For 0.37kW and 0.55kW			17x32X7		
		From 0.75 kW to 3kW			25x40x7		
200	Screw	32-125, 40-125	Stainless steel A2 70 class ISO 3506/1	M 8x30	UNI 5739	8	
		40-160, 40-200, 50-125, 50-160, 50-200, 65-125, 65-160, 65-200				M 10x35	[2]
235	Washer	32-125, 40-125	EN 1.4301 (AISI 304)	10.5x21	UNI 6592	8	
		40-160, 40-200, 50-125, 50-160,				[2]	
		50-200, 65-125, 65-160, 65-200					

Counterflange kit on request, see table p. 328-329

[1] For version 32-200, 40-200, 50-160 , 50-200

[2] Quantity = 10 for 32-160, 40-160, 50-125, 65-125

Quantity = 12 for 32-200, 40-200, 50-160, 50-200, 65-160, 65-200

[3] Special version: see page 321 and following

[4] FPM (H-HS-HW-HSW version) for H-HS-HW-HSW

EPDM for E version, Q1AEGG, U3U3EGG, U3CEGG, Q1Q1EGG, Q1U3EGG

[5] Cast iron EN-GJL-200-EN 1561 for 32-200/3 and models with 15, 18.5, 22 kW motor

Aluminum AL-EN-1706-AC-46000-D for all the others

SECTIONAL VIEW DRAWING 3LM4 80-160

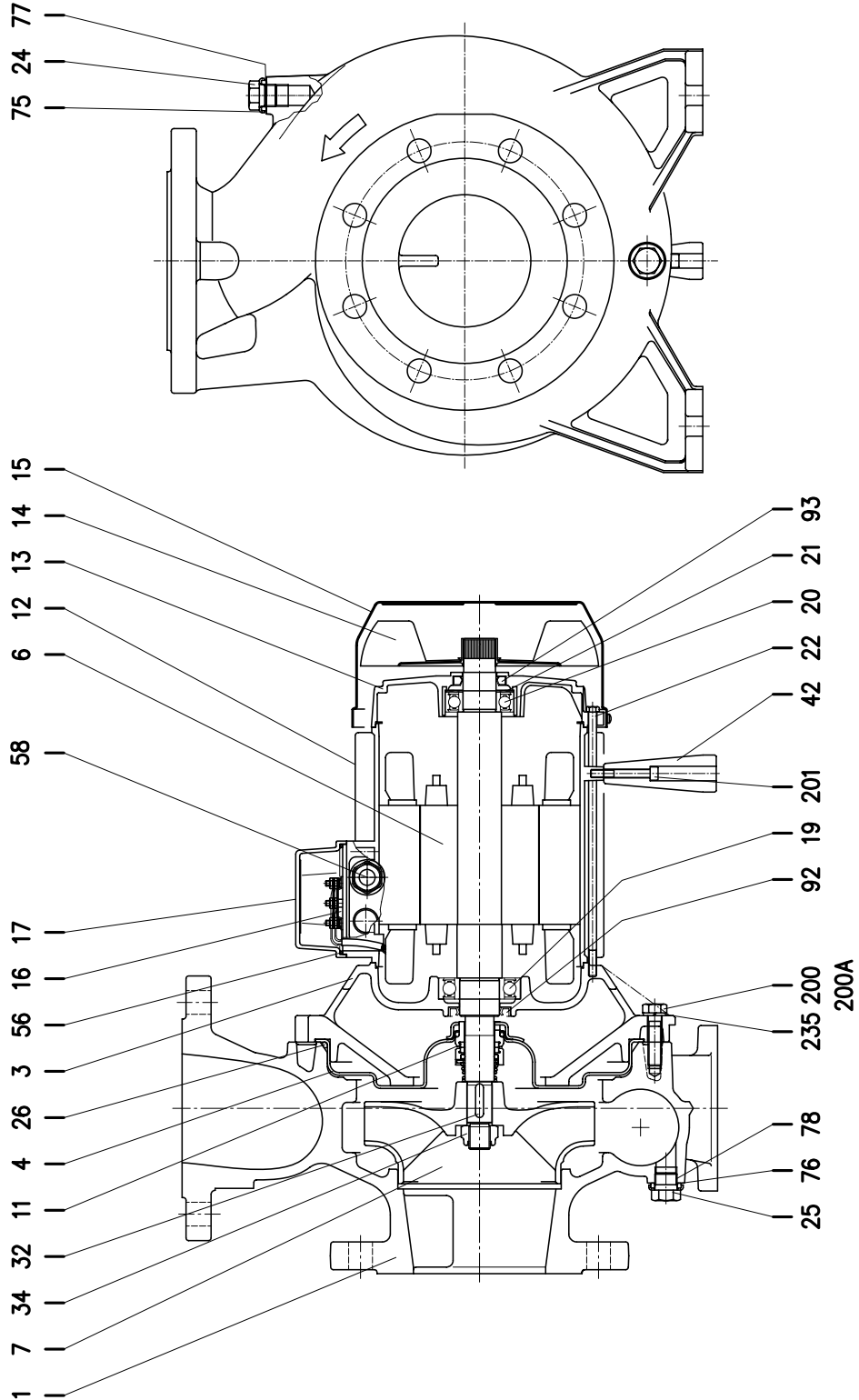

SECTIONAL VIEW TABLE 3LM4 80-160

N°	PART NAME	MATERIAL	DIMENSIONS	STANDARD	Q.TY
1	Casing	EN 1.4401 (AISI 316)			1
3	Motor bracket	Cast iron EN-GJL-200-EN 1561			1
4	Casing cover	EN 1.4404 (AISI 316L)			1
6	Shaft with rotor	EN 1.4404(AISI 316L) -Part in contact with liquid			1
7	Impeller	EN 1.4401 (AISI 316)			1
11	Mechanical seal [1]	SiC/SiC/FPM	See p. 321÷325		1
12	Motor frame with stator	-			1
13	Motor cover	Aluminium			1
14	Fan	PA			1
15	Fan cover	Fe P04 Galvanized			1
16	Terminal	-			1
17	Terminal box cover	Aluminium			1
19	Bearing	-	See table p. 319		1
20	Bearing	-	See table p. 319		1
21	Adjusting ring	Steel C70			1
22	Tie rod	Fe 42 Galvanized			4
24	Plug	EN 1.4404 (AISI 316L)	G 3/8	EPE DRAWING	1
25	Plug	EN 1.4404 (AISI 316L)	G 3/8	EPE DRAWING	1
26	"O" ring	FPM	227.96x5.34	OR 6895	1
32	Key	EN 1.4404 (AISI 316L)	6x6x25	UNI 6604	1
34	Impeller nut	EN 1.4404 (AISI 316L)	M16x1.5	UNI 7474	1
42	Foot	Aluminium		EPE DRAWING	1
56	Box gasket	NBR			1
58	Fasting nut	-			1
75	Washer (plug)	EN 1.4404 (AISI 316L)			1
76	Washer (plug)				1
77	O-ring (plug)	FPM [2]			1
78	O-ring (plug)				1
92	Lip seal	-	25x40x7	DIN 3760 w ithout spring	1
			30x47x7		
93	Lip seal	-	25x40x7		1
200	Screw	Stainless steel A2-70 class ISO 3506/1	M 10x35	UNI 5739	10
200 A	Screw		M 10x30		2
201	Screw	Stainless steel A2-70 class ISO 3506/1	M 6x40	UNI 5739	1
			M 12x40		4
235	Washer	EN 1.4301 (AISI 304)	10.5	UNI 6592	12

Counterflange kit on request, see p. 328-329

[1] Special version: see page 321 and following

[2] FPM for H-HW-HSW

EPDM for E version, Q1Q1EGG, Q1U3EGG, Q1AEGG, U3U3EGG, U3CEGG

SECTIONAL VIEW DRAWING 3LM4 65-250, 80-200/250

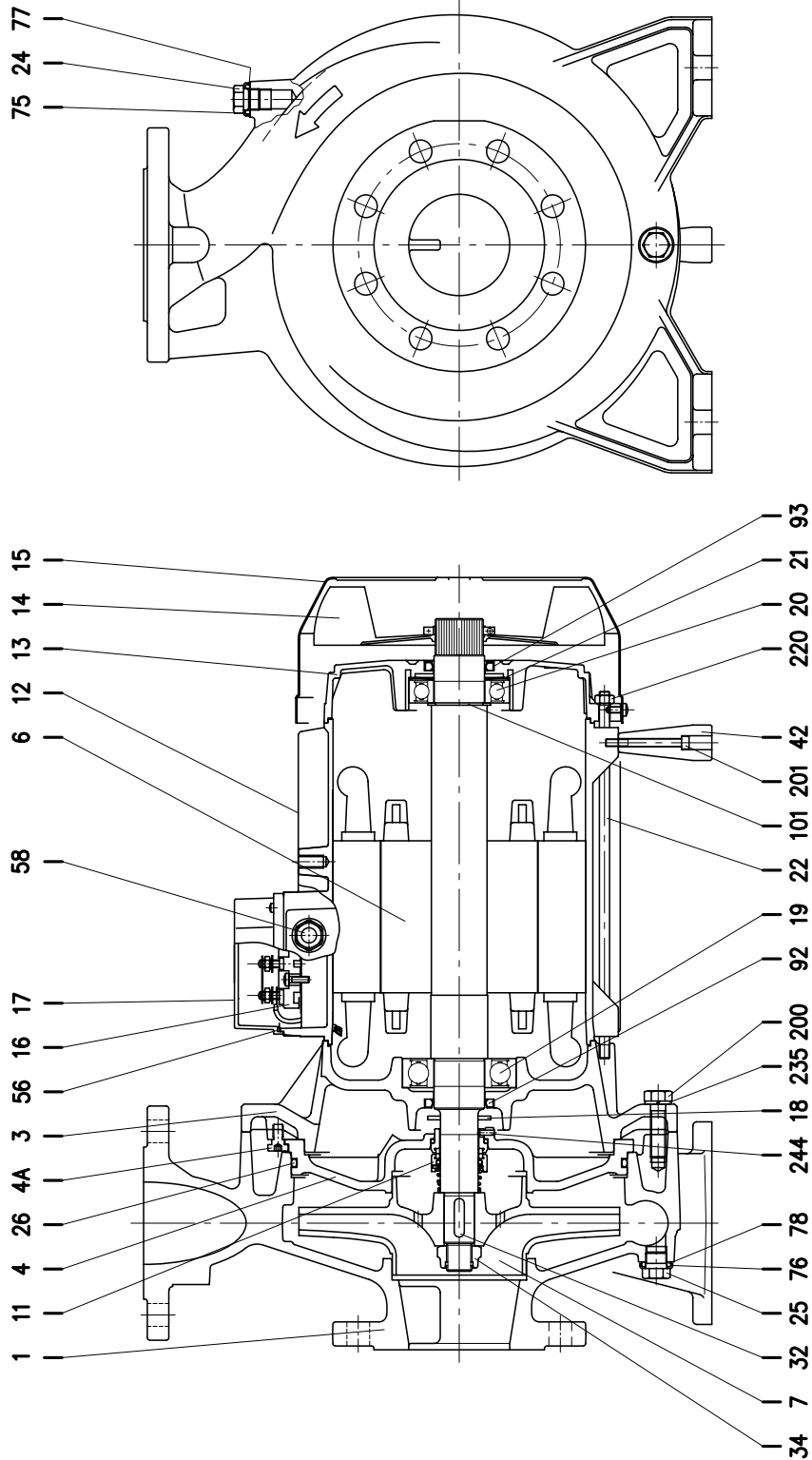

SECTIONAL VIEW TABLE 3LM4 65-250, 80-200/250

N°	PART NAME	MATERIAL	DIMENSIONS	STANDARD	Q.TY
1	Casing	EN 1.4401 (AISI 316)			1
3	Motor bracket	Cast iron EN-GJL-200-EN 1561			1
4	Casing cover	EN 1.4401 (AISI 316)			1
4 A	Screw for casing cover	EN 1.4301 (AISI 304)			2
6	Shaft w ith rotor	EN 1.4404(AISI 316L) -Part in contact w ith liquid			1
7	Impeller	EN 1.4401 (AISI 316)			1
11	Mechanical seal [2]	SiC/SiC/FPM	See p. 321+325		1
12	Motor frame w ith stator	-			1
13	Motor cover	Aluminium			1
14	Fan	PA			1
15	Fan cover	Fe P04 Galvanized			1
16	Terminal	-			1
17	Terminal box cover	Aluminium			1
18	Splash ring	NBR	50x29.5x3	EPE DRAWING	1
19	Bearing	-	See table p. 319		1
20	Bearing	-	See table p. 319		1
21	Adjusting ring	Steel C70			1
22	Tie rod	Fe 42 Galvanized			4
24	Plug	EN 1.4404 (AISI 316L)	G 3/8	EPE DRAWING	1
25	Plug	EN 1.4404 (AISI 316L)	G 3/8	EPE DRAWING	1
26	"O" ring	FPM	227.96x5.34	OR 6895	1
32	Key	EN 1.4404 (AISI 316L)	8x7x30	UNI 6604	1
34	Impeller nut	Aluminium	M20x1.5	UNI 7474	1
42	Foot	Aluminium		EPE DRAWING	1
56	Box gasket	NBR			1
58	Fasting nut	-			1
75	Washer (plug)				1
76	Washer (plug)	EN 1.4404 (AISI 316L)			1
77	O-ring (plug)				1
78	O-ring (plug)	FPM [3]			1
92	Lip sea	3 - 4 kW	30x47x7	DIN 3760 w ithout spring	1
		5.5 kW	40x55x7		
93	Lip sea	3 kW	25x40x7	DIN 3760 w ithout spring	1
		4 kW	30x47x7		
		5.5 kW	40x55x7		
101	Snap ring (only 5.5 kW)	Carbon tool steels TC 80	Ø 40	UNI 7435	1
200	Screw	Stainless steel A2-70 class ISO 3506/1	M 12x45	UNI 5739	10
201	Screw	for 80-200/4 kW	M 6x12	UNI 5739	1
		for 80-200/3 kW	M 6x45		
		for the other versions	M 6x60		
220	Nut for tie rod (only 5.5 kW)	Galvanized steel	M8		4
235	Washer	EN 1.4301(AISI 304)	13	UNI 8842	10
244	Pin [1]	EN 1.4301(AISI 304)	4x12		1

Counterflange kit on request, see table p. 328-329

[1] Not for H, HW, HSW and E options

[2] Special version: see page 321 and following

[3] FPM for H-HW-HSW

EPDM for E version, Q1AEGG, Q1Q1EGG, Q1U3EGG, U3CEGG

SECTIONAL VIEW DRAWING 3(.)S4 32, 40, 50, 65-125/160/200

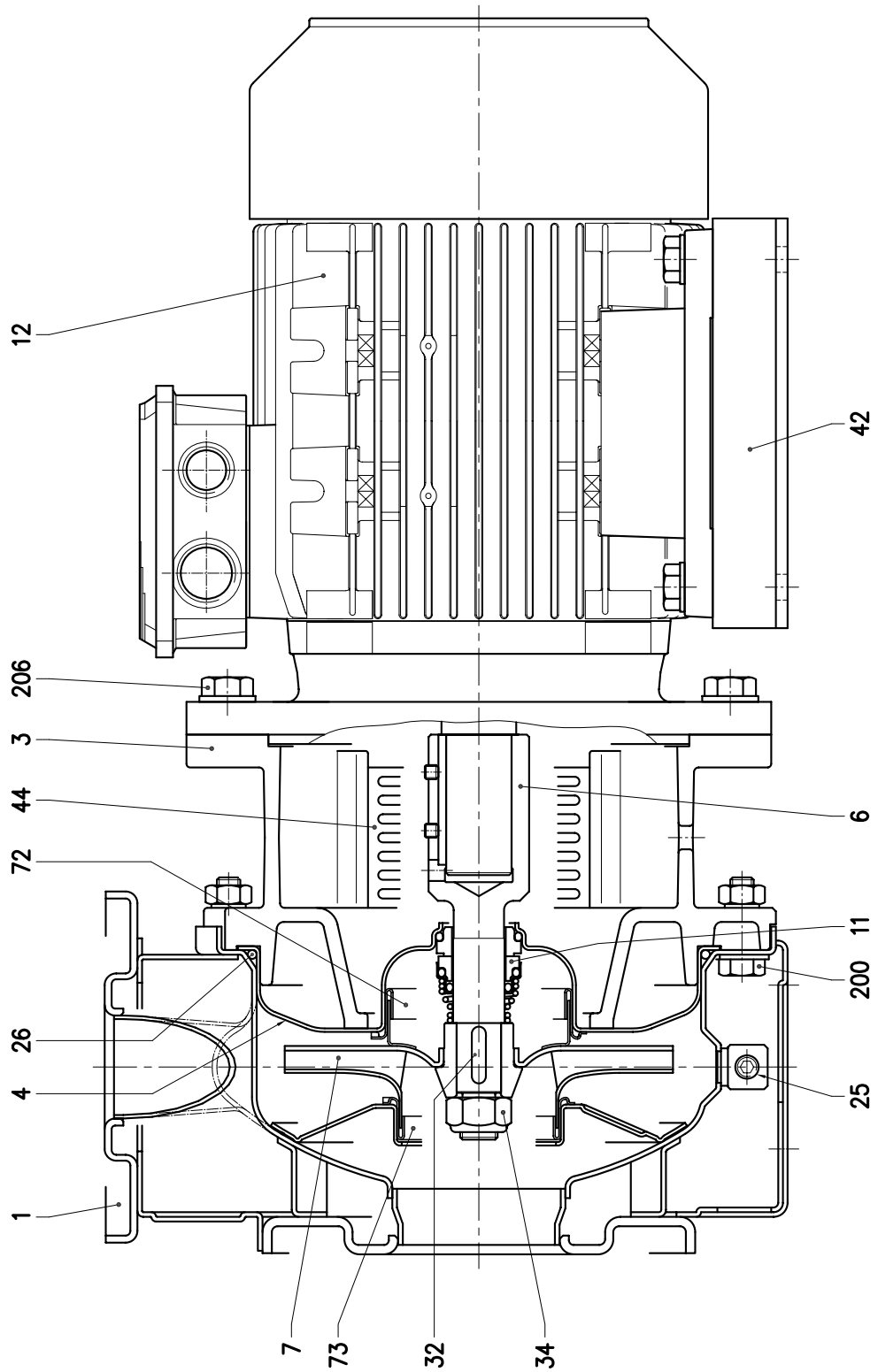

SECTIONAL VIEW TABLE 3(.)S4 32, 40, 50, 65-125/160/200

N°	PART NAME	MATERIAL		DIMENSIONS	STANDARD	Q.TY	
		3S4	3LS4				
1	Casing	EN 1.4301 (AISI 304)	EN 1.4404 (AISI 316L)			1	
3	Motor bracket	Cast iron EN-GJL-200-EN 1561				1	
4	Casing cover	EN 1.4301 (AISI 304)	EN 1.4404 (AISI 316L)			1	
6	Coupling - Part in contact with liquid	EN 1.4301 (AISI 304)	EN 1.4404 (AISI 316L)	See table p. 326		1	
7	Impeller	32, 40, 50 65-125/160/200	EN 1.4301 (AISI 304) EN 1.4404 (AISI 316L)	EN 1.4401 (AISI 316)		1	
11	Mechanical seal	[4]	Carbon/Ceramic/NBR	SiC/SiC/FPM	See p. 321+325	1	
12	Motor			-		1	
25	Drain plug	EN 1.4401 (AISI 316) / PTFE		R 1/8" L=8	DIN 906	1	
26	"O" ring	32-125, 40-125	NBR [5]	FPM [5]	158.11x5.34	OR 6625	1
		32-160, 40-160, 50-125, 65-125			183.52x5.34	OR 6720	
		32-200, 40-200, 50-160, 50-200, 65-160, 65-200			227.96x5.34	OR 6895	
32	Key	EN 1.4401 (AISI 316)		6x6x25	UNI 6604	1	
34	Impeller nut	Other model 50-200/2.2	EN 1.4301 (AISI 304)	EN 1.4404 (AISI 316L)	M16x1.5 M18x1.5	UNI 7474	1
42	Foot	Galvanized steel				[1]	
44	Protection	EN 1.4301 (AISI 304)			EBARA DRAWING	2	
72	Casing ring (not for 65 version)	[2]	EN 1.4301 (AISI 304)	EN 1.4404 (AISI 316L)		1	
73	Casing ring (not for 65 version)		EN 1.4301 (AISI 304)	EN 1.4404 (AISI 316L)		1	
200	Screw	32-125, 40-125	Stainless steel A2 70 class ISO 3506/1		M 8x30	UNI 5739	[3]
		40-160, 40-200, 50-125, 50-160, 50-200, 65-125, 65-160, 65-200			M 10x35	UNI 5739	
206	Screw	up to 0.37kW from 0.55 to 1.5kW for 2.2 and 3kW	Gv. Steel 8.8 strenght class ISO 898/1		M 8x20 M 10x25 M 12x30	UNI 5739	4

Counterflange kit on request see p. 328-329

- [1] Quantity = 1 up to 1.5kW
Quantity = 2 for 2.2 and 3kW
- [2] Only for version 32-200, 40-200, 50-160, 50-200
- [3] Quantity = 10 for 32-160, 40-160, 50-125, 65-125
Quantity = 12 for 32-200, 40-200, 50-160, 50-200, 65-160, 65-200
- [4] Special version: see page 321 and following
- [5] FPM for H-HS-HW-HSW version
EPDM for E version, Q1AEGG, U3U3EGG, Q1Q1EGG, Q1U3EGG, U3CEGG

SECTIONAL VIEW DRAWING 3LS4 80-160

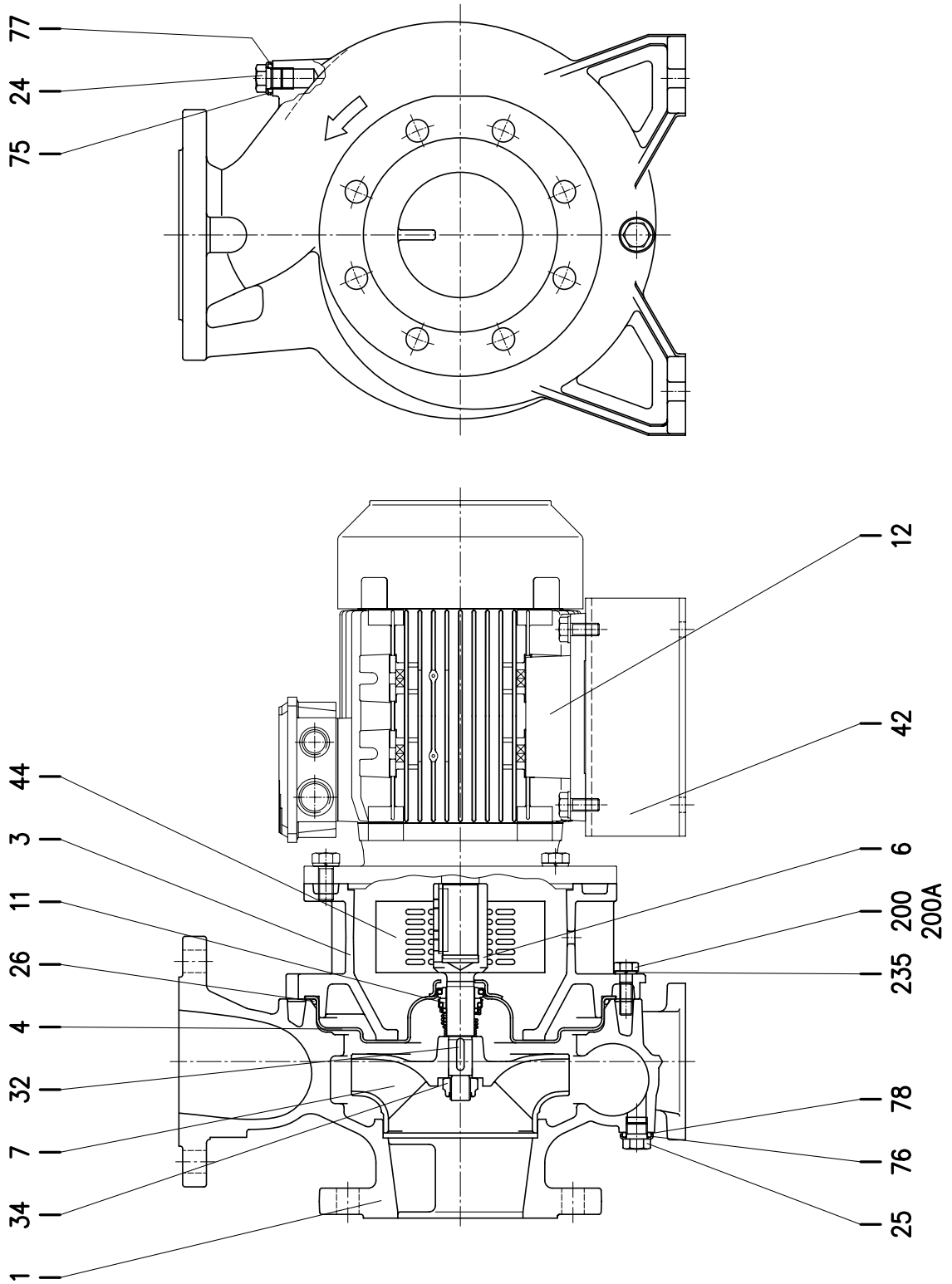

SECTIONAL VIEW TABLE 3LS4 80-160

N°	PART NAME	MATERIAL	DIMENSIONS	STANDARD
1	Casing	EN 1.4401 (AISI 316)		
3	Motor bracket	Cast iron EN-GJL-200-EN 1561		
4	Casing cover	EN 1.4404 (AISI 316L)		
6	Coupling	EN 1.4404 (AISI 316L)	See table p. 326	
7	Impeller	EN 1.4401 (AISI 316)		
11	Mechanical seal [1]	SiC/SiC/FPM	See p. 321÷325	
12	Motor	-		
24	Plug	EN 1.4404 (AISI 316L)	G3/8	EPE DRAWING
25	Plug	EN 1.4404 (AISI 316L)	G3/8	EPE DRAWING
26	"O" ring	FPM EPDM (E option)	227.96x5.34	OR 6895
32	Key	EN 1.4401 (AISI 316)	6x6x25	UNI 6604
34	Impeller nut	EN 1.4404 (AISI 316L)	M16x1.5	UNI 7474
42	Foot	Galvanized steel		EPE DRAWING
44	Protection	EN 1.4301 (AISI 304)		EPE DRAWING
75	Washer (plug)	EN 1.4404 (AISI 316L)		
76	Washer (plug)			
77	O-ring (plug)	FPM [2]		
78	O-ring (plug)			
200	Screw	Stainless steel A2-70 class ISO 3506/1	M 10x35	UNI 5739
200 A	Screw		M 10x30	
235	Washer	EN 1.4301 (AISI 304)	10.5	UNI 6592

Counterflange kit on request, see table p. 328-329

[1] Special version: see page 321 and following

[2] FPM for H-HW-HSW

EPDM for E version, Q1AEGG, Q1Q1EGG, Q1U3EGG, U3U3EGG, U3CEGG

SECTIONAL VIEW DRAWING 3LS4 65-250, 80-200/250

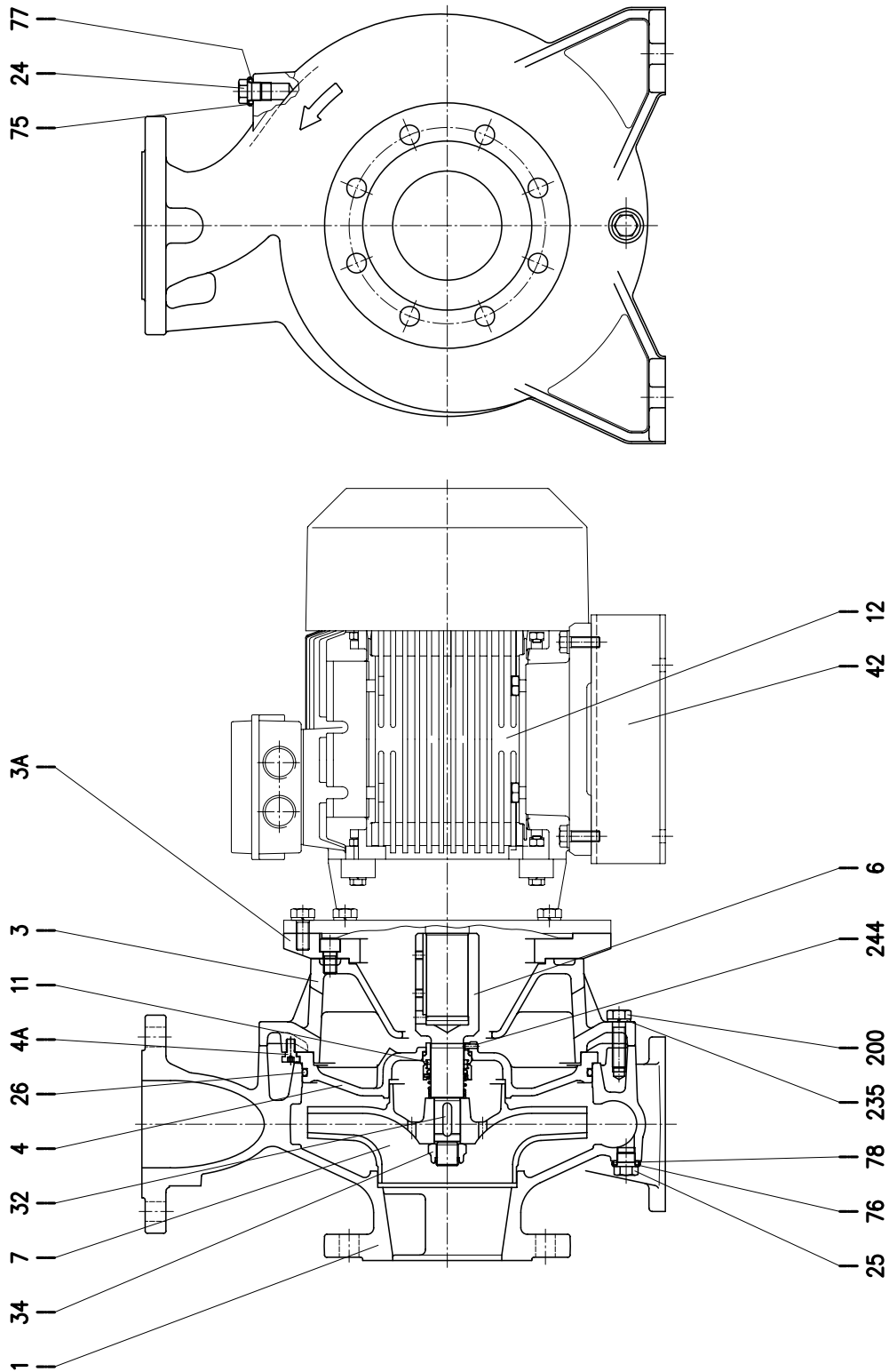

SECTIONAL VIEW TABLE 3LS4 65-250, 80-200/250

N°	PART NAME	MATERIAL	DIMENSIONS	STANDARD
1	Casing	EN 1.4401 (AISI 316)		
3	Motor bracket	Cast iron EN-GJL-200-EN 1561		
3 A	Adapter ring [1]	Cast iron EN-GJL-200-EN 1561		
4	Casing cover	EN 1.4401 (AISI 316)		
4 A	Screw for casing cover	EN 1.4301(AISI 304)		
6	Coupling	EN 1.4404 (AISI 316L)	See table p. 326	
7	Impeller	EN 1.4401 (AISI 316)		
11	Mechanical seal [3]	SiC/SiC/FPM	See p. 321÷325	
12	Motor	-		
24	Plug	EN 1.4404 (AISI 316L)	G3/8	EPE DRAWING
25	Plug	EN 1.4404 (AISI 316L)	G3/8	EPE DRAWING
26	"O" ring	FPM EPDM (E version)	253.36x5.34	OR 6995
32	Key	EN 1.4401 (AISI 316)	8x7x30	UNI 6604
34	Impeller nut	EN 1.4404 (AISI 316L)	M20x1.5	UNI 7474
42	Foot for motor	Galvanized steel		EPE DRAWING
75	Washer (plug)	EN 1.4404 (AISI 316L)		
76	Washer (plug)			
77	O-ring (plug)	FPM [4]		
78	O-ring (plug)			
200	Screw	Stainless steel A2-70 class ISO 3506/1	M 12x45	UNI 5739
235	Washer	EN 1.4301(AISI 304)	13	UNI 8842
244	Pin [2]	EN 1.4301(AISI 304)	4x12	

Counterflange kit on request, see table p. 328-329

[1] Only for 65-250/5.5 kW

[2] Not for H, HW, HSW and E options

[3] Special version: see page 321 and following

[4] FPM for H-HW-HSW

EPDM for E version, Q1AEGG, Q1Q1EGG, Q1U3EGG, U3CEGG

SECTIONAL VIEW DRAWING 3(.)P4 32, 40, 50, 65-125/160/200

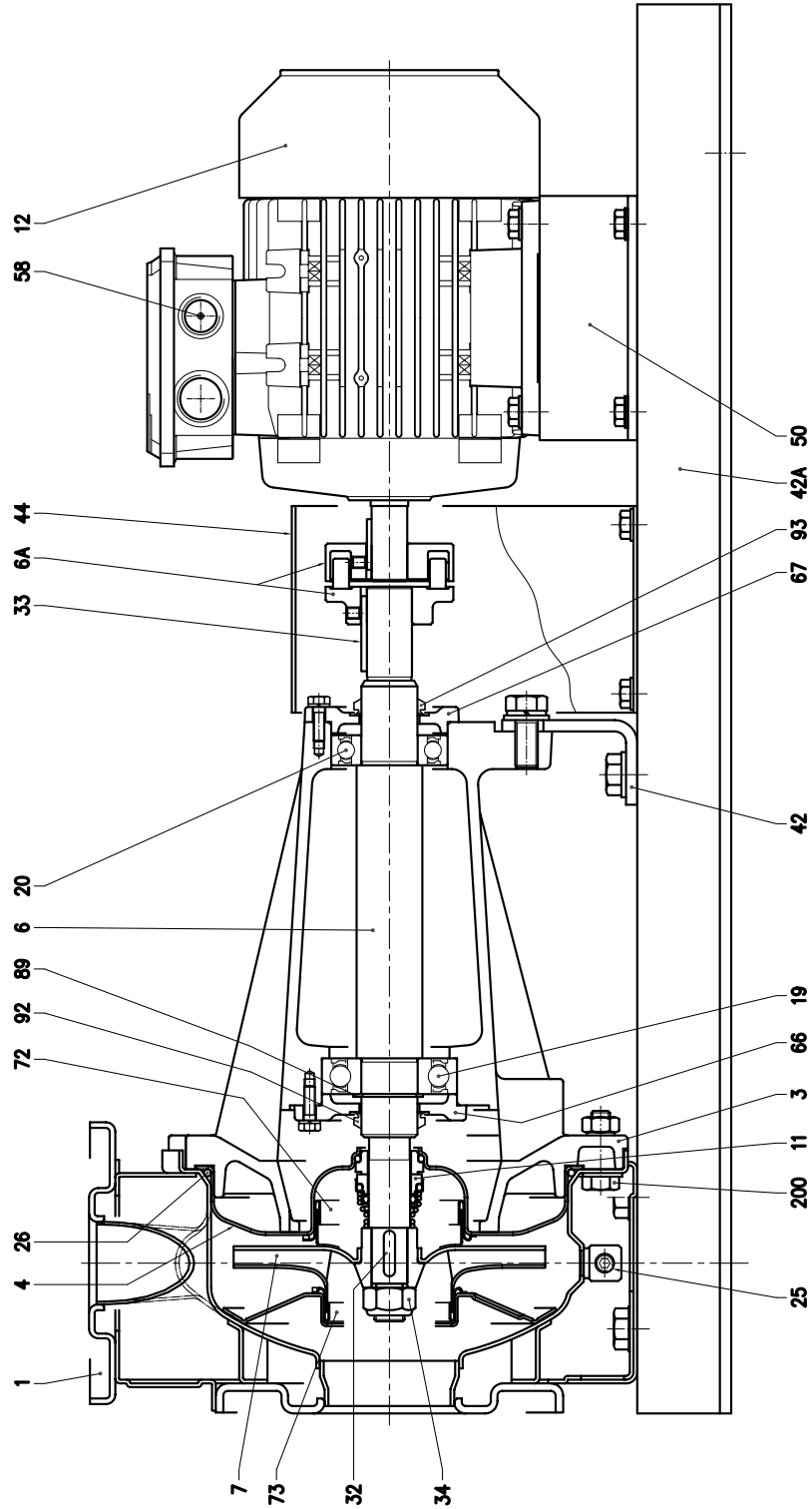

SECTIONAL VIEW TABLE 3(.)P4 32, 40, 50, 65-125/160/200

N°	PART NAME	MATERIAL		DIMENSIONS	STANDARD	Q.TY	
		3P4	3LP4				
1	Casing	EN 1.4301 (AISI 304)	EN 1.4404 (AISI 316L)			1	
3	Support	Cast iron EN-GJL-200-EN 1561				1	
4	Casing cover	EN 1.4301 (AISI 304)	EN 1.4404 (AISI 316L)			1	
6	Shaft - Part in contact with liquid	EN 1.4301 (AISI 304)	EN 1.4404 (AISI 316L)			1	
6 A	Flexible coupling	Cast iron EN-GJL-250-EN 1561		See table pag. 327		1	
7	Impeller	32-40-50 65-125/160/200	EN 1.4301 (AISI 304) EN 1.4404 (AISI 316)			1	
11	Mechanical seal	[3]	Carbon/Ceramic/NBR SiC/SiC/FPM	See p. 321-325		1	
12	Motor					1	
19	Bearing			See table p. 320		1	
20	Bearing			See table p. 320		1	
25	Draing plug	EN 1.4401 (AISI 316) / PTFE		R 1/8" L=8	DIN 906	1	
26	"O" ring	32-125, 40-125	NBR [4]	FPM [4]	158.11x5.34	1	
		32-160, 40-160, 50-125, 65-125			183.52x5.34		
		32-200, 40-200, 50-160, 50-200, 65-160, 65-200			227.96x5.34		
32	Key	EN 1.4401 (AISI 316)		6x6x25	UNI 6604	1	
33	Key	C 40		8x7x40	UNI 6604	1	
34	Impeller nut	Other model 50-200/2.2	EN 1.4301 (AISI 304)	EN 1.4404 (AISI 316L)	M16x1.5 M18x1.5	UNI 7474	1
42	Pump support	Galvanized steel			EBARA DRAWING	1	
42 A	Base	Galvanized steel				1	
44	Protection	Galvanized steel				1	
50	Foot	Galvanized steel				1	
58	Fasting nut					1	
66	Impeller side bearing cover	Cast iron EN-GJL-200-EN 1561				1	
67	Motor side bearing cover	Cast iron EN-GJL-200-EN 1561				1	
72	Casing ring (not for 65 version)	[1]	EN 1.4301 (AISI 304)	EN 1.4404 (AISI 316L)		1	
73	Casing ring (not for 65 version)		EN 1.4301 (AISI 304)	EN 1.4404 (AISI 316L)		1	
89	Snap ring	32-125, 32-160, 40-125, 50-125	Carbon tool steel TC 80		Ø30	UNI 7435	1
		Other model			Ø40		
92	"V" ring			VS - 0030		1	
93	"V" ring			VS - 0030		1	
200	Screw	32-125, 40-125	Stainless steel A2 70 class ISO 3506/1		M 8x30	UNI 5739	8
		40-160, 40-200, 50-125, 50-160, 50-200, 65-125, 65-160, 65-200			M 10x35	UNI 5739	[2]

Counterflange kit on request see p. 328-329

[1] For version: 32-200, 40-200, 50-160, 50-200

[2] Quantity = 10 for 32-160, 40-160, 50-125, 65-125

Quantity = 12 for 32-200, 40-200, 50-160, 50-200, 65-160, 65-200

[3] Special version: see page 321 and following

[4] FPM for H-HS-HW-HSW version

EPDM for E version, Q1AEGG, U3U3EGG, Q1U3EGG, Q1Q1EGG, U3CEGG

SECTIONAL VIEW DRAWING 3LP4 80-160

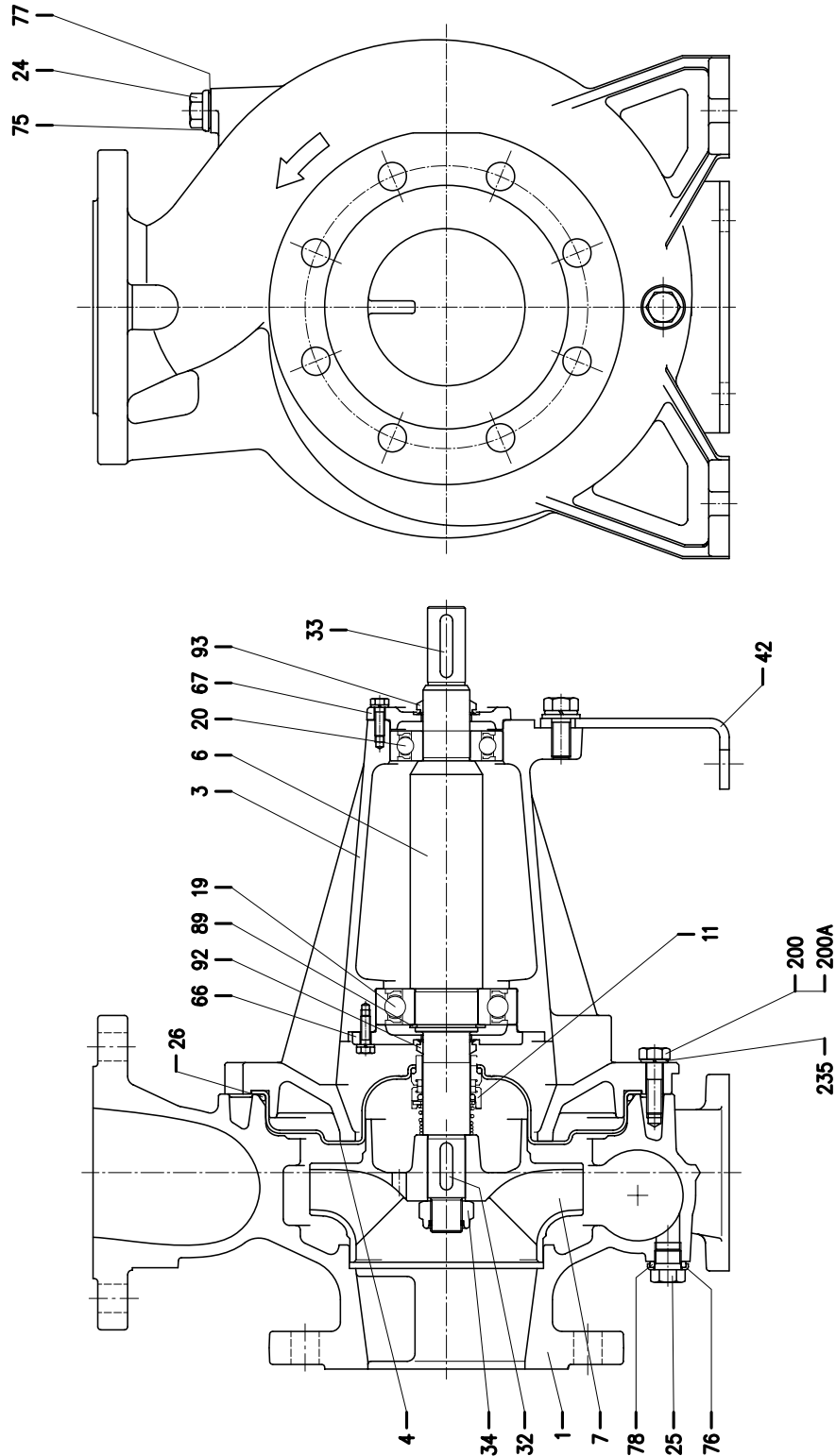

SECTIONAL VIEW DRAWING 3LP4 65-250, 80-200/250

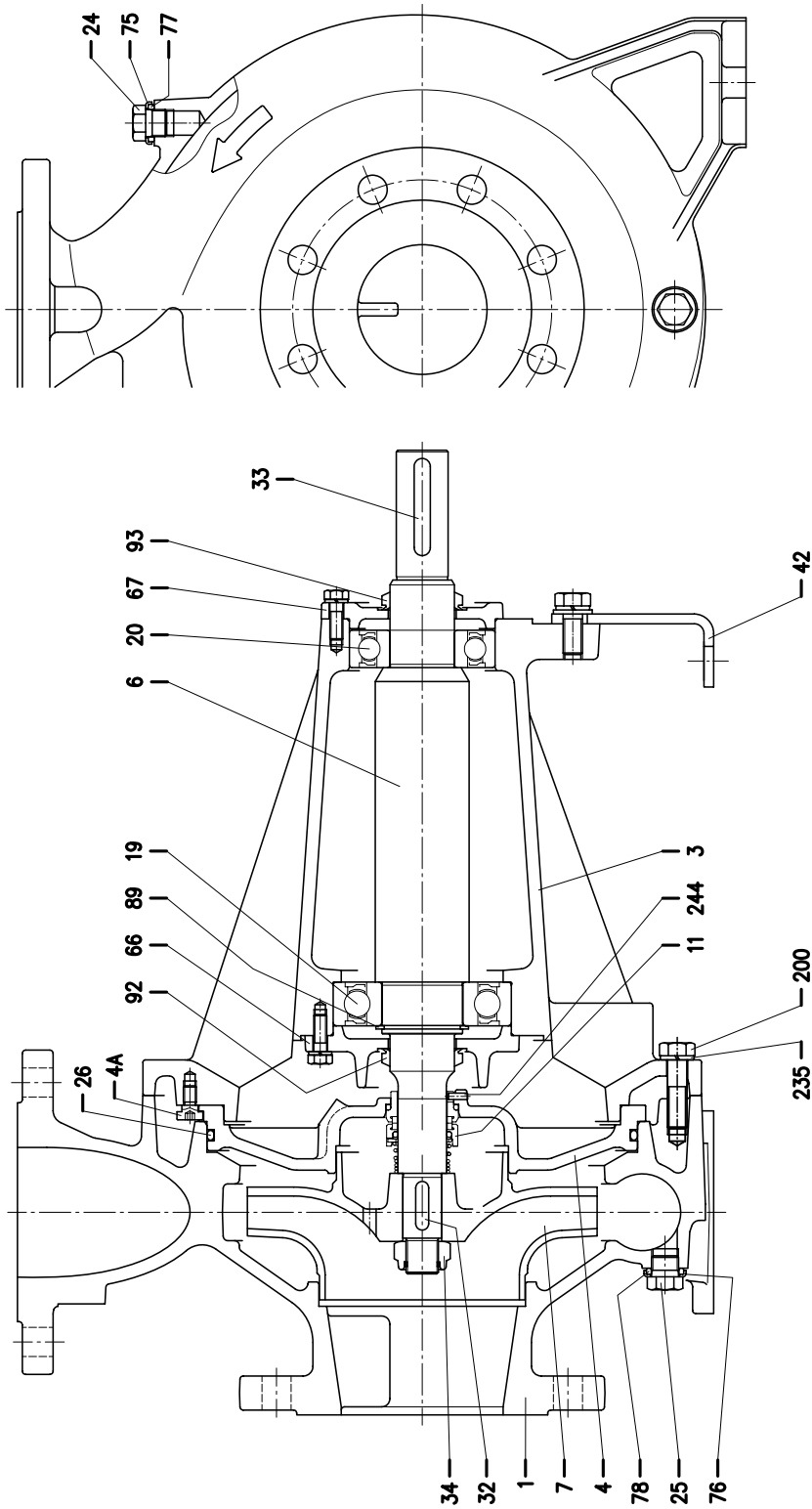

SECTIONAL VIEW DRAWING 3LP4 65-250, 80-160/200/250

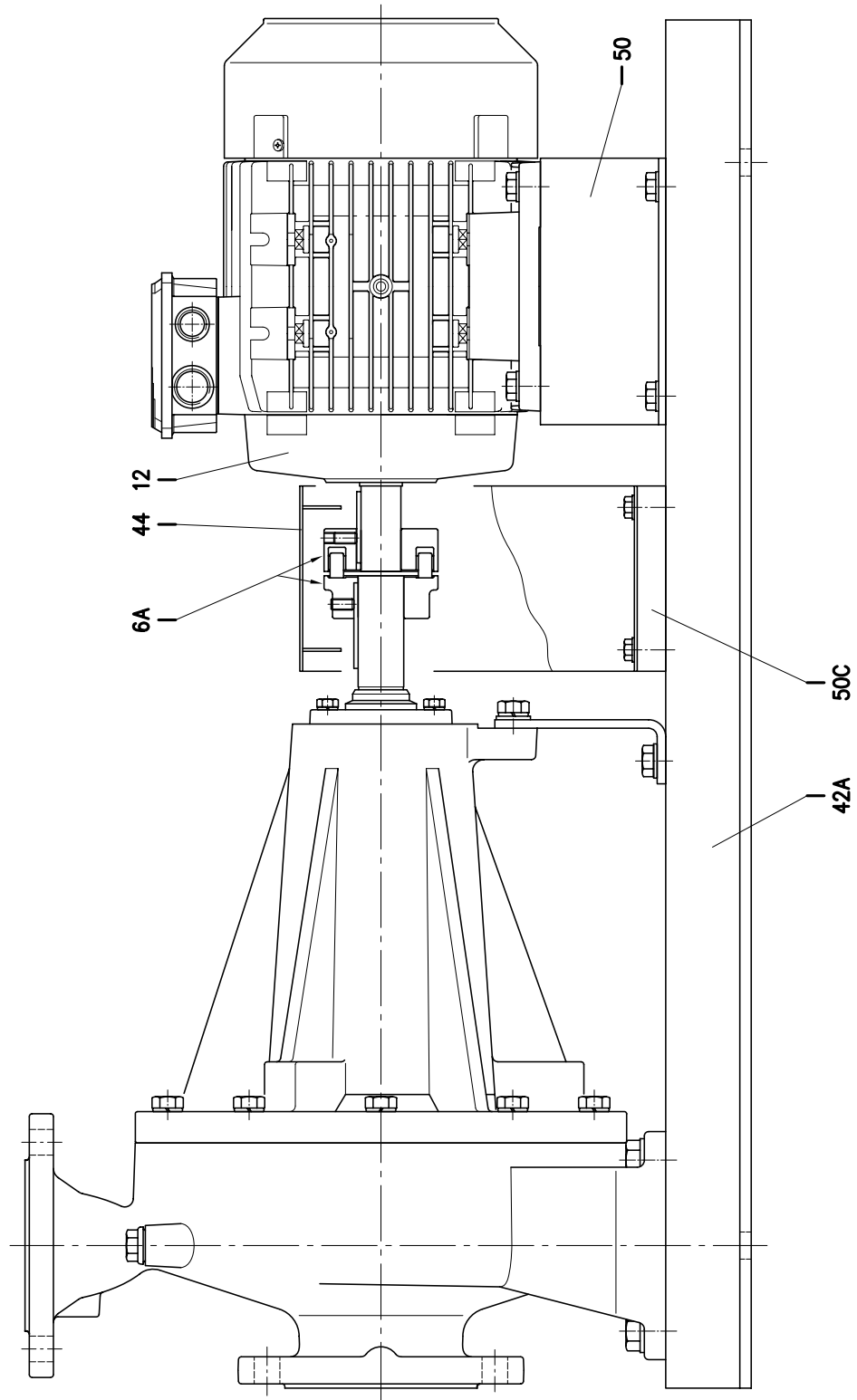

SECTIONAL VIEW TABLE 3LP4 80-160

N°	PART NAME	MATERIAL	DIMENSIONS	STANDARD	Q.TY
1	Casing	EN 1.4401 (AISI316)			1
3	Support	Cast iron EN-GJL-200-EN 1561			1
4	Casing cover	EN 1.4404 (AISI316L)			1
6	Shaft	EN 1.4404 (AISI316L)-Part in contact with liquid			1
6 A	Flexible coupling	Cast iron EN-GJL-250-EN 1561	See table p. 327		1
7	Impeller	EN 1.4401 (AISI316)			1
11	Mechanical seal [2]	SiC/SiC/FPM	See p. 321-325		1
12	Motor	-			1
19	Bearing	-	See table p. 320		1
20	Bearing	-	See table p. 320		1
24	Plug	EN 1.4404 (AISI316L)	G3/8	EPE DRAWING	1
25	Plug	EN 1.4404 (AISI316L)	G3/8	EPE DRAWING	1
26	"O" ring	FPM EPDM (E option)	227.96x5.34	OR 6895	1
32	Key	EN 1.4401 (AISI 316)	6x6x25	UNI 6604	1
33	Key	C 40	8x7x40		1
34	Impeller nut	EN 1.4404 (AISI 316L)	M16x1.5	UNI 7474	1
42	Pump support	Galvanized steel		EPE DRAWING	1
42 A	Base	Galvanized steel		EPE DRAWING	1
44	Protection	Galvanized steel		EPE DRAWING	1
50	Foot	Galvanized steel		EPE DRAWING	2
50 C	Spacer for protection [1]	Aluminium			2
66	Impeller side bearing cover	Cast iron EN-GJL-200-EN 1561			1
67	Motor side bearing cover	Cast iron EN-GJL-200-EN 1561			1
75	Washer (plug)	EN 1.4404 (AISI 316L)			1
76	Washer (plug)				1
77	O-ring (plug)	FPM [3]			1
78	O-ring (plug)				1
89	Snap ring	Carbon tool steels TC 80	Ø 40	UNI 7435	1
92	"V" ring	-	VS-0030		1
93	"V" ring				1
200	Screw	Stainless steel A2 70 class ISO 3506/1	M 10x35	UNI 5739	10
200 A	Screw		M 10x30		2
235	Washer	EN 1.4301 (AISI 304)	10.5	UNI 6592	12

Counterflange kit on request see p 328-329

[1] Only for 1.5kW

[2] Special version: see page 321 and following

[3] FPM for H-HW-HSW version

EPDM for E version, Q1Q1EGG, Q1AEGG, Q1U3EGG, U3CEGG, U3U3EGG

See p 314-316

SECTIONAL VIEW TABLE 3LP4 65-250, 80-200/250

N°	PART NAME	MATERIAL	DIMENSIONS	STANDARD
1	Casing	EN 1.4401 (AISI316)		
3	Support	Cast iron EN-GJL-200-EN 1561		
4	Casing cover	EN 1.4401 (AISI316)		
4 A	Screw for casing cover	EN 1.4301 (AISI 304)		
6	Shaft	EN 1.4462 (Duplex stainless steel)-Part in contact with liquid		
6 A	Flexible coupling	Cast iron EN-GJL-250-EN 1561	See table p. 327	
7	Impeller	EN 1.4401 (AISI316)		
11	Mechanical seal [3]	SiC/SiC/FPM	See p. 321÷325	
12	Motor	-		
19	Bearing	-	See table p. 320	
20	Bearing	-	See table p. 320	
24	Plug	EN 1.4404 (AISI316L)	G3/8	
25	Plug	EN 1.4404 (AISI316L)	G3/8	
26	"O" ring	FPM EPDM (E version)	253.36x5.34	OR 6995
32	Key	EN 1.4401 (AISI 316)	8x7x30	UNI 6604
33	Key	C 40	10x8x60	UNI 6604
34	Impeller nut	EN 1.4404 (AISI 316L)	M20x1.5	UNI 7474
42	Pump support	Galvanized steel		
42 A	Base	Galvanized steel		
44	Protection	Galvanized steel		
50	Foot	Galvanized steel		EPE DRAWING
50 C	Spacer for protection [1]	Aluminium		
66	Impeller side bearing cover	Cast iron EN-GJL-200-EN 1561		
67	Motor side bearing cover	Cast iron EN-GJL-200-EN 1561		
75	Washer (plug)	EN 1.4404 (AISI 316L)		
76	Washer (plug)			
77	O-ring (plug)	FPM [4]		
78	O-ring (plug)			
89	Snap ring	Carbon tool steels TC 80	Ø 50	UNI 7435
92	"V" ring	-	VS-0040	
93	"V" ring			
200	Screw	Stainless steel A2 70 class ISO 3506/1	M 12x45	UNI 5739
235	Washer	EN 1.4301 (AISI 304)	13	UNI 8842
244	Pin [2]	EN 1.4301 (AISI 304)	4x12	UNI 6873

Counterflange kit on request see p 328-329

[1] Only for 65-250/3-4 kW

[2] Not for H, HW, HSW and E options

[3] Special version: see page 321 and following

[4] FPM for H-HW-HSW version

EPDM for E version, Q1AEGG, Q1Q1EGG, Q1U3EGG, U3CEGG

See pages 315-316

BEARINGS 3(.)M4, 3(.)S4

Pump type	Ball bearing	
	Pump side	Fan side
3(.)M4 32-125/0.25	6205-2RSH C3	6202-2RSH
3(.)M4 32-160/0.37R		6203-2RSH
3(.)M4 32-160/0.37		
3(.)M4 32-200/0.55R		
3(.)M4 32-200/0.55		
3(.)M4 32-200/0.75		
3(.)M4 40-125/0.37R	6205-2RSH C3	6202-2RSH
3(.)M4 40-125/0.37		6203-2RSH
3(.)M4 40-160/0.55R		
3(.)M4 40-160/0.55		
3(.)M4 40-200/1.1R		
3(.)M4 40-200/1.1		
3(.)M4 40-200/1.5	6205-2RSH C3	6203-2RSH
3(.)M4 50-125/0.55R		6205-2RSH C3
3(.)M4 50-125/0.55		
3(.)M4 50-160/1.1R		
3(.)M4 50-160/1.1		
3(.)M4 50-200/1.5R		
3(.)M4 50-200/1.5	6205-2RSH C3	6203-2RSH
3(.)M4 50-200/2.2		6205-2RSH C3
3(.)M4 65-125/0.55		
3(.)M4 65-125/0.75		
3(.)M4 65-125/1.1		
3(.)M4 65-160/1.1		
3(.)M4 65-160/1.5		
3(.)M4 65-160/2.2		
3(.)M4 65-200/2.2R	3606-2RS1 C3	
3(.)M4 65-200/2.2	6206-2RS1 C3	
3(.)M4 65-200/3.0		
3LM4 65-250/4	6306-2RS1 C3	6206-2RS1 C3
3LM4 65-250/5.5	6308-2RS1 C3	6208-2RS1 C3
3LM4 80-160/1.5	6205-2RS1 C3	6205-2RS1 C3
3LM4 80-160/2.2R	6206-2RS1 C3	
3LM4 80-160/2.2		
3LM4 80-200/3		
3LM4 80-200/4R		
3LM4 80-200/4	6308-2RS1 C3	6208-2RS1 C3
3LM4 80-250/5.5R		
3LM4 80-250/5.5		

Pump type	Ball bearing	
	Pump side	Fan side
3(.)S4 32-125/0.25	6203-2Z	6203-2Z
3(.)S4 32-160/0.37R		
3(.)S4 32-160/0.37		
3(.)S4 32-200/0.55R	6204-2Z C3	6204-2Z C3
3(.)S4 32-200/0.55		
3(.)S4 32-200/0.75	6203-2Z	6203-2Z
3(.)S4 40-125/0.37R		
3(.)S4 40-125/0.37		
3(.)S4 40-160/0.55R	6204-2Z C3	6204-2Z C3
3(.)S4 40-160/0.55		
3(.)S4 40-200/1.1R	6205-2Z C3	6205-2Z C3
3(.)S4 40-200/1.1		
3(.)S4 40-200/1.5	6204-2Z C3	6204-2Z C3
3(.)S4 50-125/0.55R		
3(.)S4 50-125/0.55		
3(.)S4 50-160/1.1R	6205-2Z C3	6205-2Z C3
3(.)S4 50-160/1.1		
3(.)S4 50-200/1.5R	6206-2Z C3	6206-2Z C3
3(.)S4 50-200/1.5		
3(.)S4 50-200/2.2	6204-2Z C3	6204-2Z C3
3(.)S4 65-125/0.55		
3(.)S4 65-125/0.75		
3(.)S4 65-125/1.1	6205-2Z C3	6205-2Z C3
3(.)S4 65-160/1.1		
3(.)S4 65-160/1.5	6206-2Z C3	6206-2Z C3
3(.)S4 65-160/2.2		
3(.)S4 65-200/2.2R		
3(.)S4 65-200/2.2	6306-2Z C3	6306-2Z C3
3(.)S4 65-200/3.0		
3LS4 65-250/4	6208-2Z C3	6208-2Z C3
3LS4 65-250/5.5	6205-2Z C3	6205-2Z C3
3LS4 80-160/1.5	6206-2Z C3	6206-2Z C3
3LS4 80-160/2.2R		
3LS4 80-160/2.2	6306-2Z C3	6306-2Z C3
3LS4 80-200/3		
3LS4 80-200/4R	6208-2Z C3	6208-2Z C3
3LS4 80-200/4		
3LS4 80-250/5.5R	6208-2Z C3	6208-2Z C3
3LS4 80-250/5.5		
3LS4 80-250/7.5		

BEARINGS 3(.)P4

Pump type	Ball bearing			
	Pump		Motor	
	Pump side	Motor side	Pump side	Fan side
3(.)P4 32-125/0.25				
3(.)P4 32-160/0.37R	6306-2RS1 C3	6206-2RS1 C3	6203-2Z	6203-2Z
3(.)P4 32-160/0.37				
3(.)P4 32-200/0.55R				
3(.)P4 32-200/0.55	6308-2RS1 C3	6306-2RS1 C3	6204-2Z C3	6204-2Z C3
3(.)P4 32-200/0.75				
3(.)P4 40-125/0.37R			6203-2Z	6203-2Z
3(.)P4 40-125/0.37	6306-2RS1 C3	6206-2RS1 C3		
3(.)P4 40-160/0.55R			6204-2Z C3	6204-2Z C3
3(.)P4 40-160/0.55				
3(.)P4 40-200/1.1R				
3(.)P4 40-200/1.1	6308-2RS1 C3	6306-2RS1 C3	6205-2Z C3	6205-2Z C3
3(.)P4 40-200/1.5				
3(.)P4 50-125/0.55R	6306-2RS1 C3	6206-2RS1 C3	6204-2Z C3	6204-2Z C3
3(.)P4 50-125/0.55				
3(.)P4 50-160/1.1R				
3(.)P4 50-160/1.1			6205-2Z C3	6205-2Z C3
3(.)P4 50-200/1.5R	6308-2RS1 C3	6306-2RS1 C3		
3(.)P4 50-200/1.5				
3(.)P4 50-200/2.2			6206-2Z C3	6206-2Z C3
3(.)P4 65-125/0.55				
3(.)P4 65-125/0.75	6306-2RS1 C3	6206-2RS1 C3	6204-2Z C3	6204-2Z C3
3(.)P4 65-125/1.1				
3(.)P4 65-160/1.1			6205-2Z C3	6205-2Z C3
3(.)P4 65-160/1.5				
3(.)P4 65-160/2.2	6308-2RS1 C3	6306-2RS1 C3		
3(.)P4 65-200/2.2R			6206-2Z C3	6206-2Z C3
3(.)P4 65-200/2.2				
3(.)P4 65-200/3				
3LP4 65-250/4	6310-2RS1 C3	6308-2RS1 C3	6306-2Z C3	6306-2Z C3
3LP4 65-250/5.5			6208-2Z C3	6208-2Z C3
3LP4 80-160/1.5			6205-2Z C3	6205-2Z C3
3LP4 80-160/2.2R	6308-2RS1 C3	6308-2RS1 C3		
3LP4 80-160/2.2			6206-2Z C3	6206-2Z C3
3LP4 80-200/3				
3LP4 80-200/4R			6306-2Z C3	6306-2Z C3
3LP4 80-200/4	6310-2RS1 C3	6308-2RS1 C3		
3LP4 80-250/5.5R				
3LP4 80-250/5.5			6208-2Z C3	6208-2Z C3
3LP4 80-250/7.5				

MECHANICAL SEAL (standard, H, E and Special version)

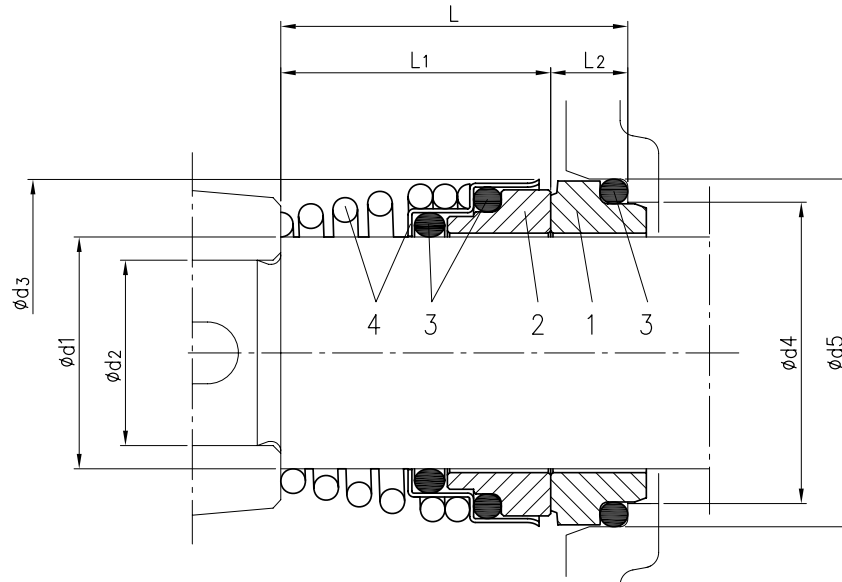

Version	Pump type	Dimensions								Material			
		d1	d2	d3	d4	d5	L	L1	L2	1 Stationary seal ring	2 Rotary seal ring	3 Rubber	4 Frame + spring
Standard	32-125/160/200	22	19	38	31	37	37.5	27.5	10	Carbon	Ceramic	NBR	EN 1.4401 (AISI 316)
	40-125/160/200												
	50-125/160/200												
	65-125/160/200												
H	32-125/160/200	22	19	38	31	37	37.5	27.5	10	Carbon	Ceramic	FPM	EN 1.4401 (AISI 316)
	40-125/160/200												
	50-125/160/200												
	65-125/160/200												
	80-160												
65-250	30	24	46	39	45	42.5	32.5	10					
80-200/250													
E	32-125/160/200	22	19	38	31	37	37.5	27.5	10	Carbon	Ceramic	EPDM	EN 1.4401 (AISI 316)
	40-125/160/200												
	50-125/160/200												
	65-125/160/200												
	80-160												
65-250	30	24	46	39	45	42.5	32.5	10					
80-200/250													
Q1AEGG*	65-250	30	24	46	39	45	43	33	10	Silicon Carbide	Metallised Carbon	EPDM	EN 1.4401 (AISI 316)
	80-200/250												

* The drawing is only indicative

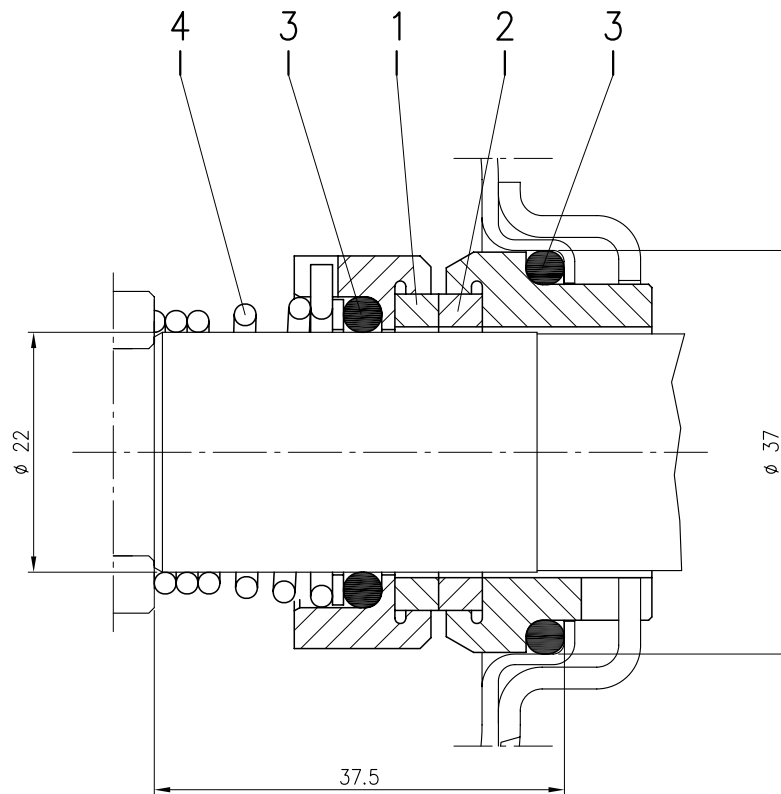
MECHANICAL SEAL (L version $\phi 22$)

Version	Pump type	Material			
		1 Stationary seal ring	2 Rotary seal ring	3 Rubber	4 Frame + spring
L $\phi 22$	32-125/160/200 40-125/160/200 50-125/160/200 65-125/160/200 80-160	SiC	SiC	FPM	EN 1.4571 (AISI 316Ti)

MECHANICAL SEAL (L version ø30)

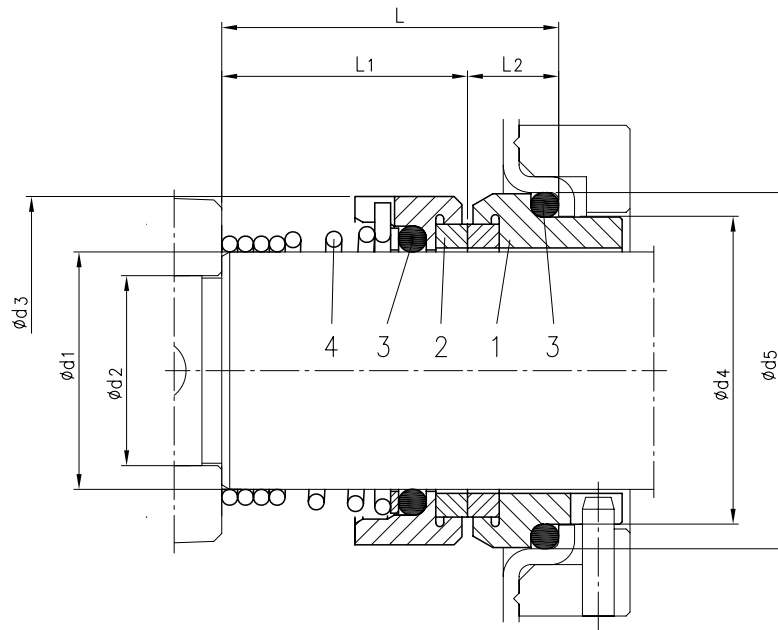

Version	Pump type	Dimensions									Material			
		d1	d2	d3	d4	d5	L	L1	L2	1 Stationary seal ring	2 Rotary seal ring	3 Rubber	4 Frame + spring	
L ø30	65-250 80-200/250	30	24	44	39	45	42.5	31	11.5	SiC	SiC	FPM	EN 1.4571 (AISI 316Ti)	

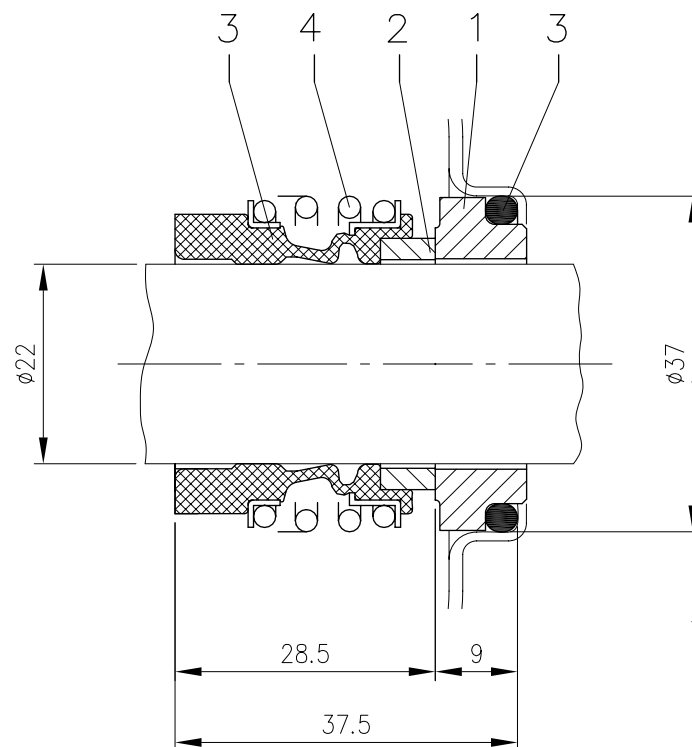
MECHANICAL SEAL (HS version e Special version Ø22)

Version	Pump type	Material			
		1 Stationary seal ring	2 Rotary seal ring	3 Rubber	4 Frame + spring
HS Ø22	32-125/160/200	SiC	SiC	FPM	EN 1.4571 (AISI 316Ti)
	40-125/160/200				
	50-125/160/200				
	65-125/160/200				
Q1AEGG*	32-125/160/200	Silicon Carbide	Metallised Carbon	EPDM	EN 1.4401 (AISI 316)
	40-125/160/200				
	50-125/160/200				
	65-125/160/200				
	80-160				

* The drawing is only indicative

MECHANICAL SEAL (HW, HSW and Special version)

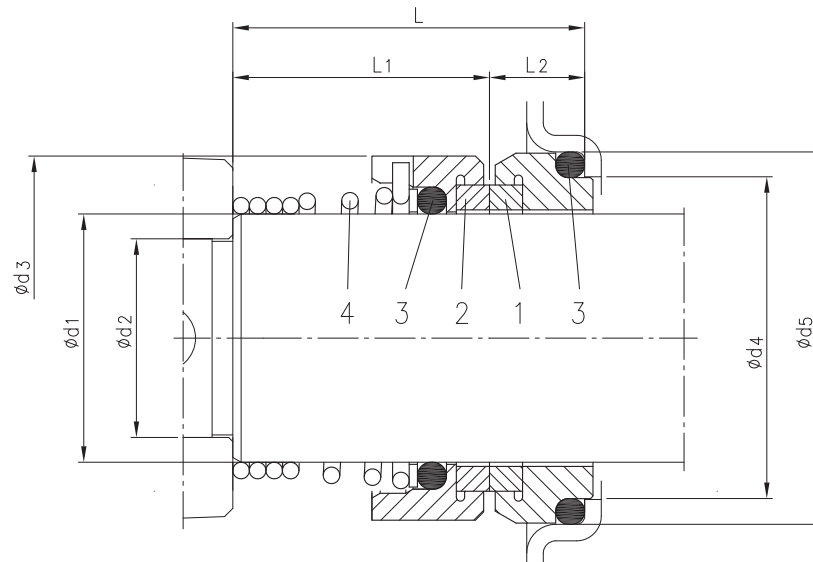

Version	Pump type	Dimensions								Material			
		d1	d2	d3	d4	d5	L	L1	L2	1 Stationary seal ring	2 Rotary seal ring	3 Rubber	4 Frame + spring
HW	32-125/160/200 40-125/160/200 50-125/160/200 65-125/160/200 80-160	22	19	38	31	37	37,5	27,5	10	Tungsten Carbide	Tungsten Carbide	FPM	EN 1.4401 (AISI 316)
	65-250 80-200/250	30	24	46	39	45	42,5	32,5	10				
HSW	32-125/160/200 40-125/160/200 50-125/160/200 65-125/160/200 80-160	22	19	38	31	37	37,5	27,5	10	Tungsten Carbide	SiC	FPM	EN 1.4401 (AISI 316)
	65-250 80-200/250	30	24	46	39	45	42,5	32,5	10				
U3U3EGG*	32-125/160/200 40-125/160/200 50-125/160/200 65-125/160/200 80-160	22	19	38	31	37	37,5	27,5	10	Tungsten Carbide	Tungsten Carbide	EPDM	EN 1.4401 (AISI 316)
Q1Q1EGG*	32-125/160/200 40-125/160/200 50-125/160/200 65-125/160/200 80-160	22	19	38	31	37	37,5	27,5	10	Silicon Carbide	Silicon Carbide	EPDM	EN 1.4401 (AISI 316)
	65-250 80-200/250	30	24	46	39	45	42,5	32,5	10				
Q1U3EGG*	32-125/160/200 40-125/160/200 50-125/160/200 65-125/160/200 80-160	22	19	38	31	37	37,5	27,5	10	Silicon Carbide	Tungsten Carbide	EPDM	EN 1.4401 (AISI 316)
	65-250 80-200/250	30	24	46	39	45	42,5	32,5	10				
U3CEGG*	32-125/160/200 40-125/160/200 50-125/160/200 65-125/160/200 80-160	22	19	38	31	37	37,5	27,5	10	Tungsten Carbide	Special Carbon	EPDM	EN 1.4401 (AISI 316)
	65-250 80-200/250	30	24	46	39	45	42,5	32,5	10				

* The drawing is only indicative

COUPLING 3(.)S4

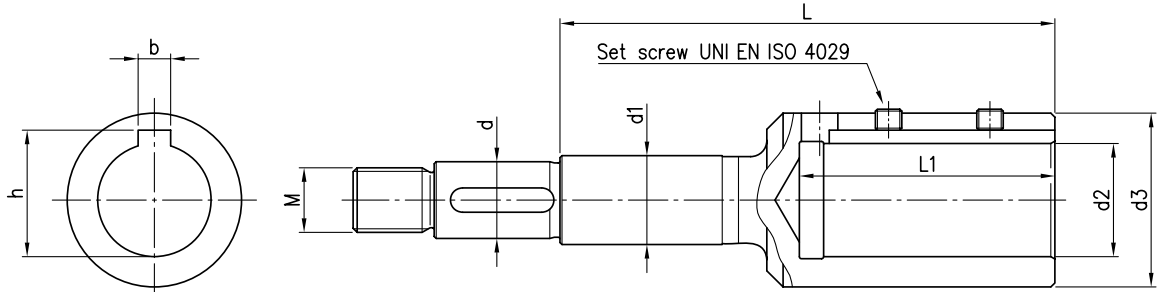

Pump type	[kW]	[HP]	Motor Size	Dimensions mm									
				d	d1	d2	d3	M	L	L1	b	h	Set screw
32-125/0.25	0.25	0.33	71	19	22	14	28	M16x1.5	88	33	5	16.3	M5x6
32-160/0.37R	0.37	0.5	71	19	22	14	28	M16x1.5	88	33	5	16.3	M5x6
32-160/0.37	0.37	0.5	71	19	22	14	28	M16x1.5	88	33	5	16.3	M5x6
32-200/0.55R	0.55	0.75	80	19	22	19	33	M16x1.5	98	43	6	21.8	M6x6
32-200/0.55	0.55	0.75	80	19	22	19	33	M16x1.5	98	43	6	21.8	M6x6
32-200/0.75	0.75	1	80	19	22	19	33	M16x1.5	98	43	6	21.8	M6x6
40-125/0.37R	0.37	0.5	71	19	22	14	28	M16x1.5	88	33	5	16.3	M5x6
40-125/0.37	0.37	0.5	71	19	22	14	28	M16x1.5	88	33	5	16.3	M5x6
40-160/0.55R	0.55	0.75	80	19	22	19	33	M16x1.5	98	43	6	21.8	M6x6
40-160/0.55	0.55	0.75	80	19	22	19	33	M16x1.5	98	43	6	21.8	M6x6
40-200/1.1R	1.1	1.5	90	19	22	24	39	M16x1.5	110	53	8	27.3	M8x8
40-200/1.1	1.1	1.5	90	19	22	24	39	M16x1.5	110	53	8	27.3	M8x8
40-200/1.5	1.5	2	90	19	22	24	39	M16x1.5	110	53	8	27.3	M8x8
50-125/0.55R	0.55	0.75	80	19	22	19	33	M16x1.5	98	43	6	21.8	M6x6
50-125/0.55	0.55	0.75	80	19	22	19	33	M16x1.5	98	43	6	21.8	M6x6
50-160/1.1R	1.1	1.5	90	19	22	24	39	M16x1.5	110	53	8	27.3	M8x8
50-160/1.1	1.1	1.5	90	19	22	24	39	M16x1.5	110	53	8	27.3	M8x8
50-200/1.5R	1.5	2	90	19	22	24	39	M16x1.5	110	53	8	27.3	M8x8
50-200/1.5	1.5	2	90	19	22	24	39	M16x1.5	110	53	8	27.3	M8x8
50-200/2.2	2.2	3	100	22	22	28	43	M18x1.5	153	63	8	31.3	M8x8
65-125/0.55	0.55	0.75	80	19	22	19	33	M16x1.5	98	43	6	21.8	M6x6
65-125/0.75	0.75	1	80	19	22	19	33	M16x1.5	98	43	6	21.8	M6x6
65-125/1.1	1.1	1.5	90	19	22	24	39	M16x1.5	110	53	8	27.3	M8x8
65-160/1.1	1.1	1.5	90	19	22	24	39	M16x1.5	110	53	8	27.3	M8x8
65-160/1.5	1.5	2	90	19	22	24	39	M16x1.5	110	53	8	27.3	M8x8
65-160/2.2	2.2	3	100	19	22	28	43	M16x1.5	122	63	8	31.3	M8x8
65-200/2.2R	2.2	3	100	19	22	28	43	M16x1.5	122	63	8	31.3	M8x8
65-200/2.2	2.2	3	100	19	22	28	43	M16x1.5	122	63	8	31.3	M8x8
80-200/3	3	4	100	19	22	28	43	M16x1.5	122	63	8	31.3	M8x8
65-250/4	4	5.5	112	24	30	28	43	M20x1.5	128	63	8	31.3	M8x8
65-250/5.5	5.5	7.5	132	24	30	38	58	M20x1.5	151	84	10	41.3	M8x8
80-160/1.5	1.5	2	90	19	22	24	39	M16x1.5	110	53	8	27.3	M8x8
80-160/2.2R	2.2	3	100	19	22	28	43	M16x1.5	122	63	8	31.3	M8x8
80-160/2.2	2.2	3	100	19	22	28	43	M16x1.5	122	63	8	31.3	M8x8
80-200/3	3	4	100	24	30	28	43	M20x1.5	128	63	8	31.3	M8x8
80-200/4R	4	5.5	112	24	30	28	43	M20x1.5	128	63	8	31.3	M8x8
80-200/4	4	5.5	112	24	30	28	43	M20x1.5	128	63	8	31.3	M8x8
80-250/5.5R	5.5	7.5	132	24	30	38	58	M20x1.5	151	84	10	41.3	M8x8
80-250/5.5	5.5	7.5	132	24	30	38	58	M20x1.5	151	84	10	41.3	M8x8
80-250/7.5	7.5	10	132	24	30	38	58	M20x1.5	151	84	10	41.3	M8x8

FLEXIBLE COUPLING 3(.)P4

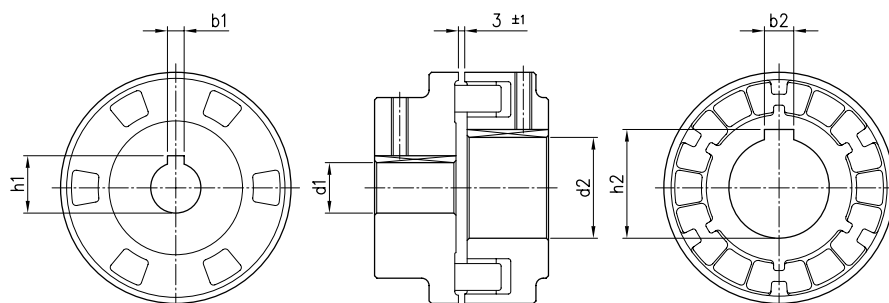

Pump type	[kW]	[HP]	Motor Size	Dimensions mm					
				d1	b1	h1	d2	b2	h2
32-125/0.25	0.25	0.33	71	24	8	27.3	14	5	16.3
32-160/0.37R	0.37	0.5	71	24	8	27.3	14	5	16.3
32-160/0.37	0.37	0.5	71	24	8	27.3	14	5	16.3
32-200/0.55R	0.55	0.75	80	24	8	27.3	19	6	21.8
32-200/0.55	0.55	0.75	80	24	8	27.3	19	6	21.8
32-200/0.75	0.75	1	80	24	8	27.3	19	6	21.8
40-125/0.37R	0.37	0.5	71	24	8	27.3	14	5	16.3
40-125/0.37	0.37	0.5	71	24	8	27.3	14	5	16.3
40-160/0.55R	0.55	0.75	80	24	8	27.3	19	6	21.8
40-160/0.55	0.55	0.75	80	24	8	27.3	19	6	21.8
40-200/1.1R	1.1	1.5	90	24	8	27.3	24	8	27.3
40-200/1.1	1.1	1.5	90	24	8	27.3	24	8	27.3
40-200/1.5	1.5	2	90	24	8	27.3	24	8	27.3
50-125/0.55R	0.55	0.75	80	24	8	27.3	19	6	21.8
50-125/0.55	0.55	0.75	80	24	8	27.3	19	6	21.8
50-160/1.1R	1.1	1.5	90	24	8	27.3	24	8	27.3
50-160/1.1	1.1	1.5	90	24	8	27.3	24	8	27.3
50-200/1.5R	1.5	2	90	24	8	27.3	24	8	27.3
50-200/1.5	1.5	2	90	24	8	27.3	24	8	27.3
50-200/2.2	2.2	3	100	24	8	27.3	28	8	31.3
65-125/0.55	0.55	0.75	80	24	8	27.3	19	6	21.8
65-125/0.75	0.75	1	80	24	8	27.3	19	6	21.8
65-125/1.1	1.1	1.5	90	24	8	27.3	24	8	27.3
65-160/1.1	1.1	1.5	90	24	8	27.3	24	8	27.3
65-160/1.5	1.5	2	90	24	8	27.3	24	8	27.3
65-160/2.2	2.2	3	100	24	8	27.3	28	8	31.3
65-200/2.2R	2.2	3	100	24	8	27.3	28	8	31.3
65-200/2.2	2.2	3	100	24	8	27.3	28	8	31.3
65-200/3	3	4	100	24	8	27.3	28	8	31.3
65-250/4	4	5.5	112	32	10	35.3	28	8	31.3
65-250/5.5	5.5	7.5	132	32	10	35.3	38	10	41.3
80-160/1.5	1.5	2	90	24	8	27.3	24	8	27.3
80-160/2.2R	2.2	3	100	24	8	27.3	28	8	31.3
80-160/2.2	2.2	3	100	24	8	27.3	28	8	31.3
80-200/3	3	4	100	32	10	35.3	28	8	31.3
80-200/4R	4	5.5	112	32	10	35.3	28	8	31.3
80-200/4	4	5.5	112	32	10	35.3	28	8	31.3
80-250/5.5R	5.5	7.5	132	32	10	35.3	38	10	41.3
80-250/5.5	5.5	7.5	132	32	10	35.3	38	10	41.3
80-250/7.5	7.5	10	132	32	10	35.3	38	10	41.3

FITTINGS

COUNTERFLANGE ZINCKED STEEL

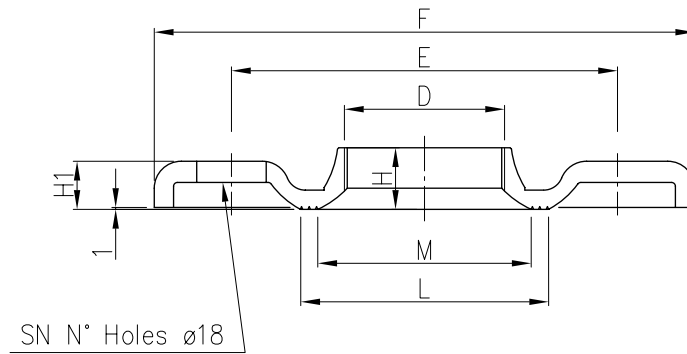

DN	Counterflange								Screw	
	D	E	F	H	H1	L	M	SN	DIMENSIONS	MATERIAL
32	G 1 1/4	100	140	15	11.5	67	50	4	M16x55	Gv. Steel 8.8 strenght class ISO 898-1
40	G 1 1/2	110	150	17.5	11.5	72	58	4		
50	G2	125	165	19	15	89	70	4		
65	G 2 1/2	145	185	23	14	104	88	4		
80	G3	160	200	24	16	117.5	100	8	M16x60	
100	G4	180	220	29	16	144	125	8		

COUNTERFLANGE EN 1.4404 (AISI 316L)

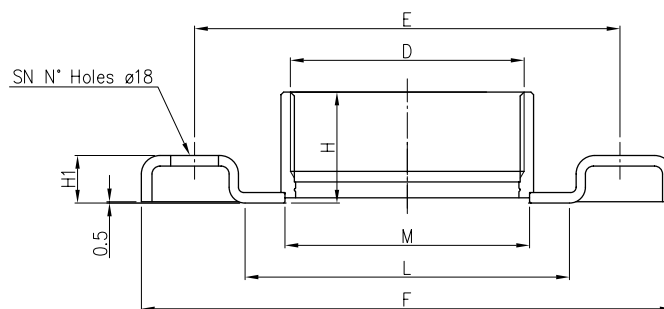

DN	Counterflange								Screw	
	D	E	F	H	H1	L	M	SN	DIMENSIONS	MATERIAL
32	G 1 1/4	100	140	29.5	14	66	44	4	M16x55	A2-70 class ISO 3506-1
40	G 1 1/2	110	150	29.5	14	71	50.5			
50	G 2	125	165	34	16	83	63			
65	G 2 1/2	145	185	40	16	103	80			
80	G3	160	200	42	18	122	92	8	M16x60	

COUNTERFLANGE EN 1.4404 (AISI 316L) DN100

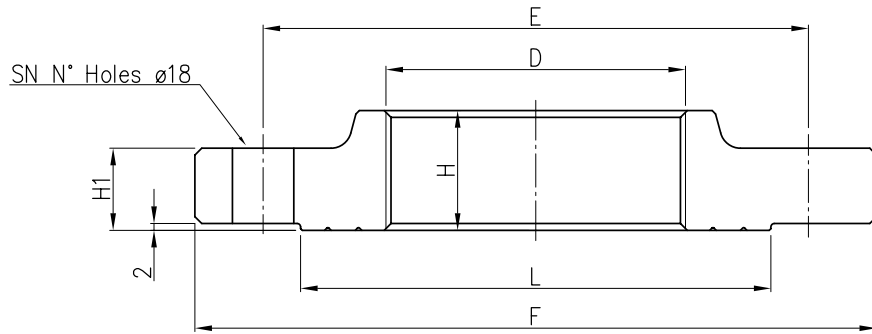

Counterflange								Screw	
DN	D	E	F	H	H1	L	SN	DIMENSIONS	MATERIAL
100	G4	180	220	35	20	150	8	M16x70	A2-70 class ISO 3506-1

GASKET

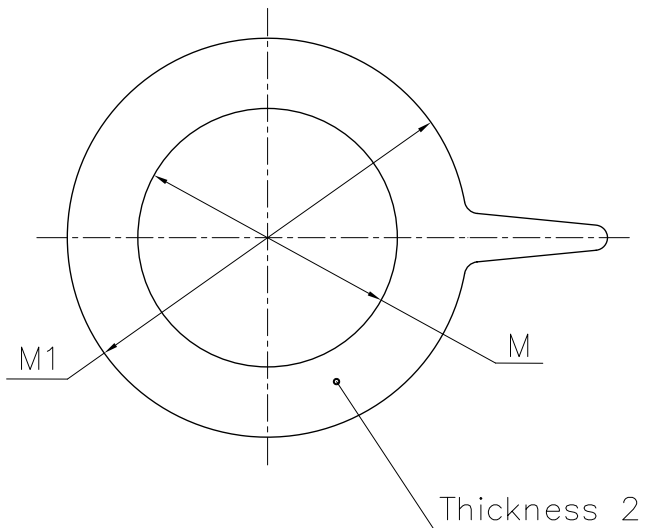

DN	M	M1
32	38	82
40	50	93
50	60	107
65	80	125
80	90	140
100	115	160

Material : EPDM for standard version
FPM for L version

PUMP 3(.)M4 32, 40, 50, 65-125/160/200

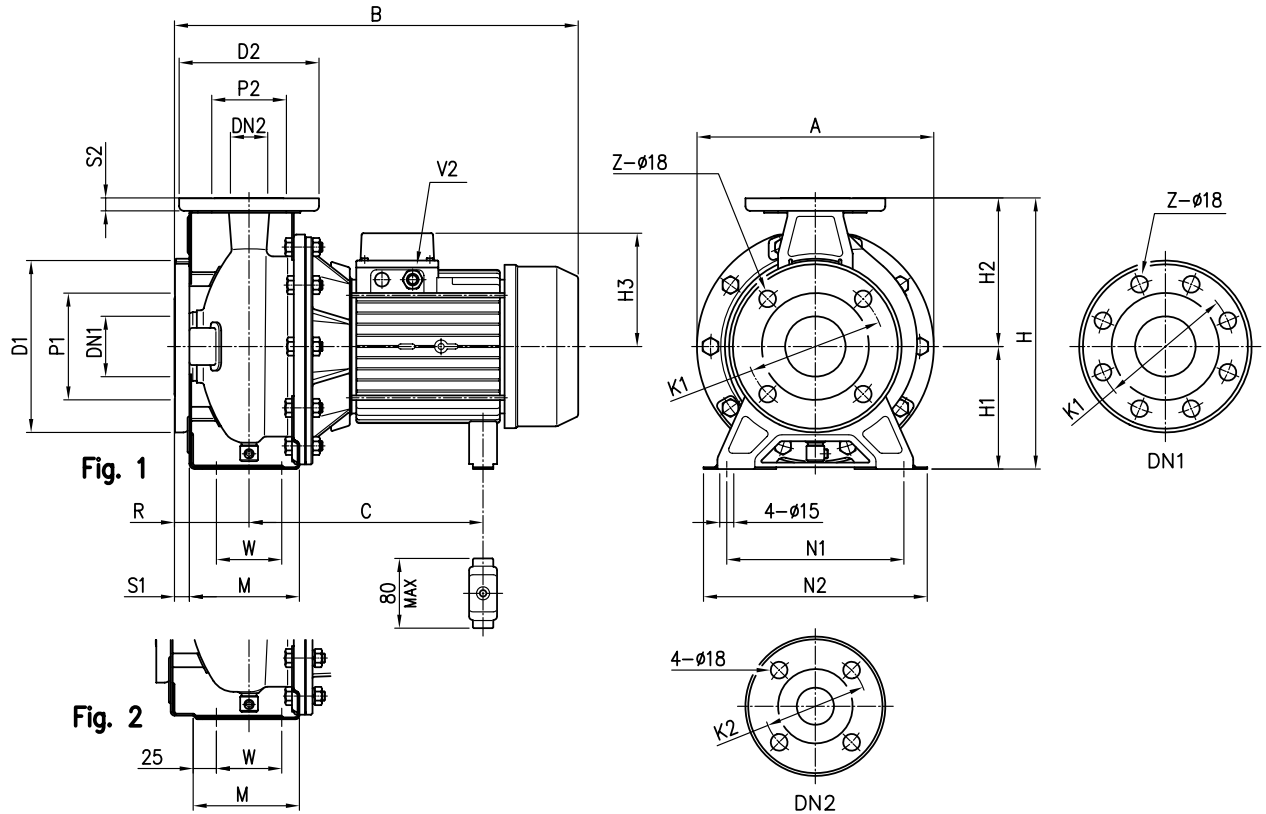

Pump type	Dimensions (mm)																							Weight [kg]			
	Ø DN1	Ø P1	Ø K1	Ø D1	S1	Z [1]	Z [2]	Ø DN2	Ø P2	Ø K2	Ø D2	S2	Fig.	H	H1	H2	H3	R	W	M	N1	N2	A		B	C	V2
32-125/0.25	50	95	125	165	16	4	-	32	75	100	140	14	1	252	112	140	102	80	70	114	140	190	213	371	205	PG 11	15
32-160/0.37R	50	95	125	165	16	4	-	32	75	100	140	14	1	292	132	160	119	80	70	118	190	240	254	393	219	PG 11	19.7
32-160/0.37	50	95	125	165	16	4	-	32	75	100	140	14	1	292	132	160	119	80	70	118	190	240	254	393	219	PG 11	19.9
32-200/0.55R	50	95	125	165	16	4	-	32	75	100	140	14	1	340	160	180	119	80	70	119	190	240	296	393	219	PG 11	24.5
32-200/0.55	50	95	125	165	16	4	-	32	75	100	140	14	1	340	160	180	119	80	70	119	190	240	296	393	219	PG 11	24.5
32-200/0.75	50	95	125	165	16	4	-	32	75	100	140	14	1	340	160	180	124	80	70	119	190	240	296	432	244+255	PG 13.5	28.1
40-125/0.37R	65	115	145	185	16	4	-	40	80	110	150	14	1	252	112	140	102	80	70	114	160	210	213	371	205	PG 11	15.6
40-125/0.37	65	115	145	185	16	4	-	40	80	110	150	14	1	252	112	140	102	80	70	114	160	210	213	371	205	PG 11	15.7
40-160/0.55R	65	115	145	185	16	4	-	40	80	110	150	14	1	292	132	160	119	80	70	118	190	240	254	393	219	PG 11	20.2
40-160/0.55	65	115	145	185	16	4	-	40	80	110	150	14	1	292	132	160	119	80	70	118	190	240	254	393	219	PG 11	20.6
40-200/1.1R	65	115	145	185	16	4	-	40	80	110	150	14	2	340	160	180	124	100	70	115	212	265	296	452	244+255	PG 13.5	28.5
40-200/1.1	65	115	145	185	16	4	-	40	80	110	150	14	2	340	160	180	124	100	70	115	212	265	296	452	244+255	PG 13.5	28.6
40-200/1.5	65	115	145	185	16	4	-	40	80	110	150	14	2	340	160	180	124	100	70	115	212	265	296	491	244+255	PG 13.5	30.3
50-125/0.55R	65	115	145	185	16	4	-	50	95	125	165	16	2	292	132	160	119	100	70	114	190	240	254	413	219	PG 11	20.4
50-125/0.55	65	115	145	185	16	4	-	50	95	125	165	16	2	292	132	160	119	100	70	114	190	240	254	413	219	PG 11	20.5
50-160/1.1R	65	115	145	185	16	4	-	50	95	125	165	16	2	340	160	180	124	100	70	115	212	265	296	452	244+255	PG 13.5	28.6
50-160/1.1	65	115	145	185	16	4	-	50	95	125	165	16	2	340	160	180	124	100	70	115	212	265	296	452	244+255	PG 13.5	28.7
50-200/1.5R	65	115	145	185	16	4	-	50	95	125	165	16	2	360	160	200	124	100	70	115	212	265	296	491	244+255	PG 13.5	30.5
50-200/1.5	65	115	145	185	16	4	-	50	95	125	165	16	2	360	160	200	124	100	70	115	212	265	296	491	244+255	PG 13.5	31.6
50-200/2.2	65	115	145	185	16	4	-	50	95	125	165	16	2	360	160	200	141	100	70	115	212	265	296	474	253	PG 16	30
65-125/0.55	80	134	160	200	18	8	4	65	115	145	185	16	2	340	160	180	119	100	95	140	212	280	254	413	219	PG 11	21.9
65-125/0.75	80	134	160	200	18	8	4	65	115	145	185	16	2	340	160	180	124	100	95	140	212	280	254	452	244+255	PG 13.5	20
65-125/1.1	80	134	160	200	18	8	4	65	115	145	185	16	2	340	160	180	124	100	95	140	212	280	254	452	244+255	PG 13.5	20
65-160/1.1	80	134	160	200	18	8	4	65	115	145	185	16	2	360	160	200	124	100	95	140	212	280	296	452	244+255	PG 13.5	28.5
65-160/1.5	80	134	160	200	18	8	4	65	115	145	185	16	2	360	160	200	124	100	95	140	212	280	296	491	244+255	PG 13.5	30
65-160/2.2	80	134	160	200	18	8	4	65	115	145	185	16	2	360	160	200	141	100	95	140	212	280	296	474	253	PG 16	32
65-200/2.2R	80	134	160	200	18	8	4	65	115	145	185	16	2	405	180	225	141	100	95	140	250	320	296	474	253	PG 16	30
65-200/2.2	80	134	160	200	18	8	4	65	115	145	185	16	2	405	180	225	141	100	95	140	250	320	296	474	253	PG 16	30
65-200/3	80	134	160	200	18	8	4	65	115	145	185	16	2	405	180	225	141	100	95	140	250	320	296	514	253	PG 16	38

[1] Standard [2] On request

PUMP 3(.)M4 65-250, 80-160/200, 80-250/5.5

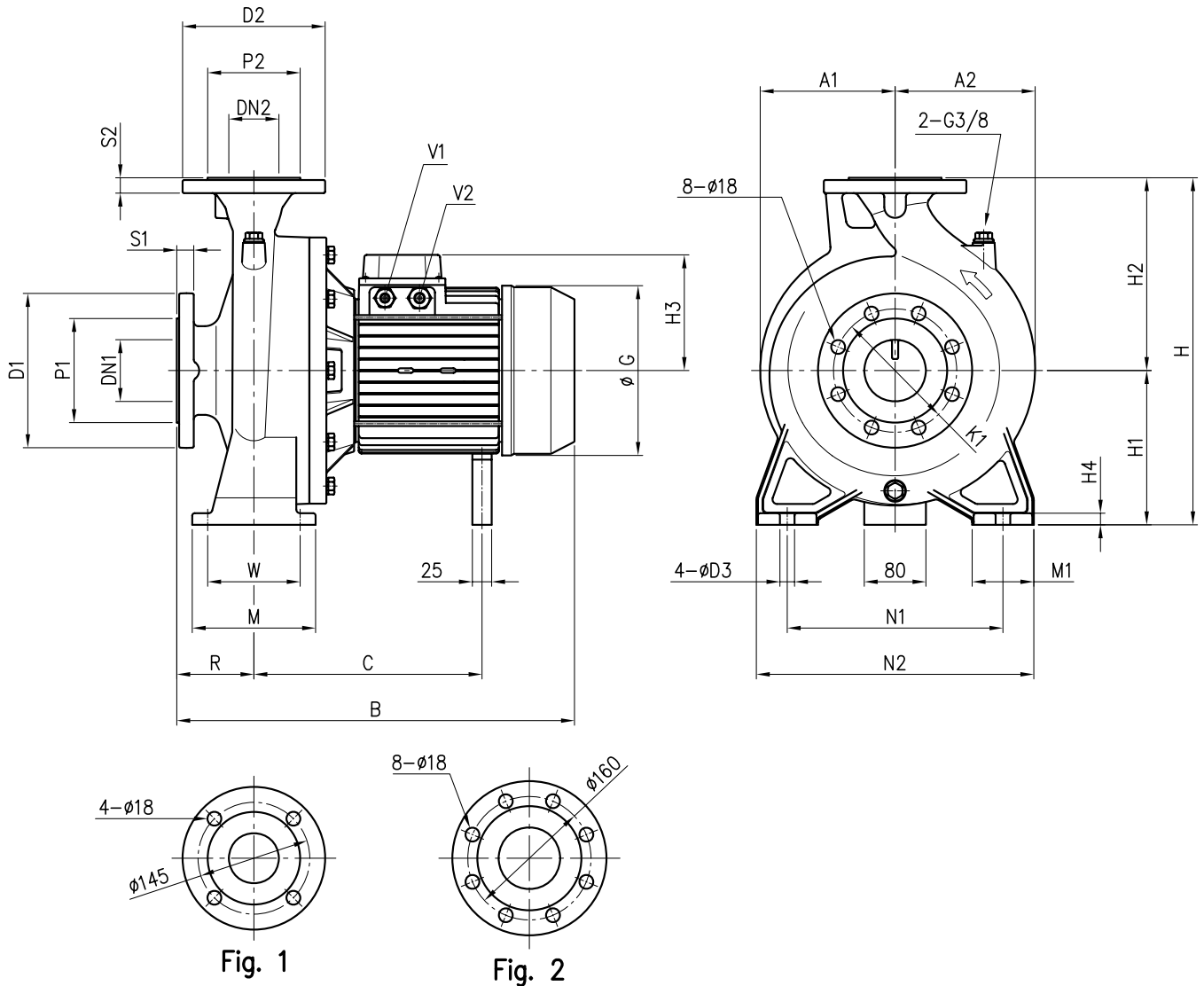

Pump type	Dimensions [mm]																							Weight [kg]					
	DN1	P1	K1	D1	S1	DN2	P2	D2	S2	H	H1	H2	H3	H4	R	W	N1	N2	M	M1	A1	A2	B		C	G	D3	V1	V2
65-250/4	80	135	160	200	22	65 Fig. 1	120	185	20	450	200	250	150	15	100	120	280	360	160	80	175	182	559	295	220	19	PG13.5	PG16	81
65-250/5.5	80	135	160	200	22	65 Fig. 1	120	185	20	450	200	250	178	15	100	120	280	360	160	80	175	182	612	376	259	19	PG13.5	PG21	96
80-160/1.5	100	155	180	225	24	80 Fig. 2	135	200	22	405	180	225	124	13	125	95	250	320	125	65	147	173	516	244+255	176	15	-	PG13.5	53
80-160/2.2R	100	155	180	225	24	80 Fig. 2	135	200	22	405	180	225	141	13	125	95	250	320	125	65	147	173	499	253	193	15	-	PG16	53
80-160/2.2	100	155	180	225	24	80 Fig. 2	135	200	22	405	180	225	141	13	125	95	250	320	125	65	147	173	499	253	193	15	-	PG16	53
80-200/3	100	155	180	225	24	80 Fig. 2	135	200	22	430	180	250	141	13	125	95	280	345	125	65	175	182	561	275	193	15	-	PG16	73
80-200/4R	100	155	180	225	24	80 Fig. 2	135	200	22	430	180	250	150	13	125	95	280	345	125	65	175	182	584	295	220	15	PG13.5	PG16	80
80-200/4	100	155	180	225	24	80 Fig. 2	135	200	22	430	180	250	150	13	125	95	280	345	125	65	175	182	584	295	220	15	PG13.5	PG16	81
80-250/5.5R	100	155	180	225	24	80 Fig. 2	135	200	22	480	200	280	178	15	125	120	315	400	160	80	175	192	637	376	259	19	PG13.5	PG21	94
80-250/5.5	100	155	180	225	24	80 Fig. 2	135	200	22	480	200	280	178	15	125	120	315	400	160	80	175	192	637	376	259	19	PG13.5	PG21	95

PUMP 3(.)M4 80-250/7.5

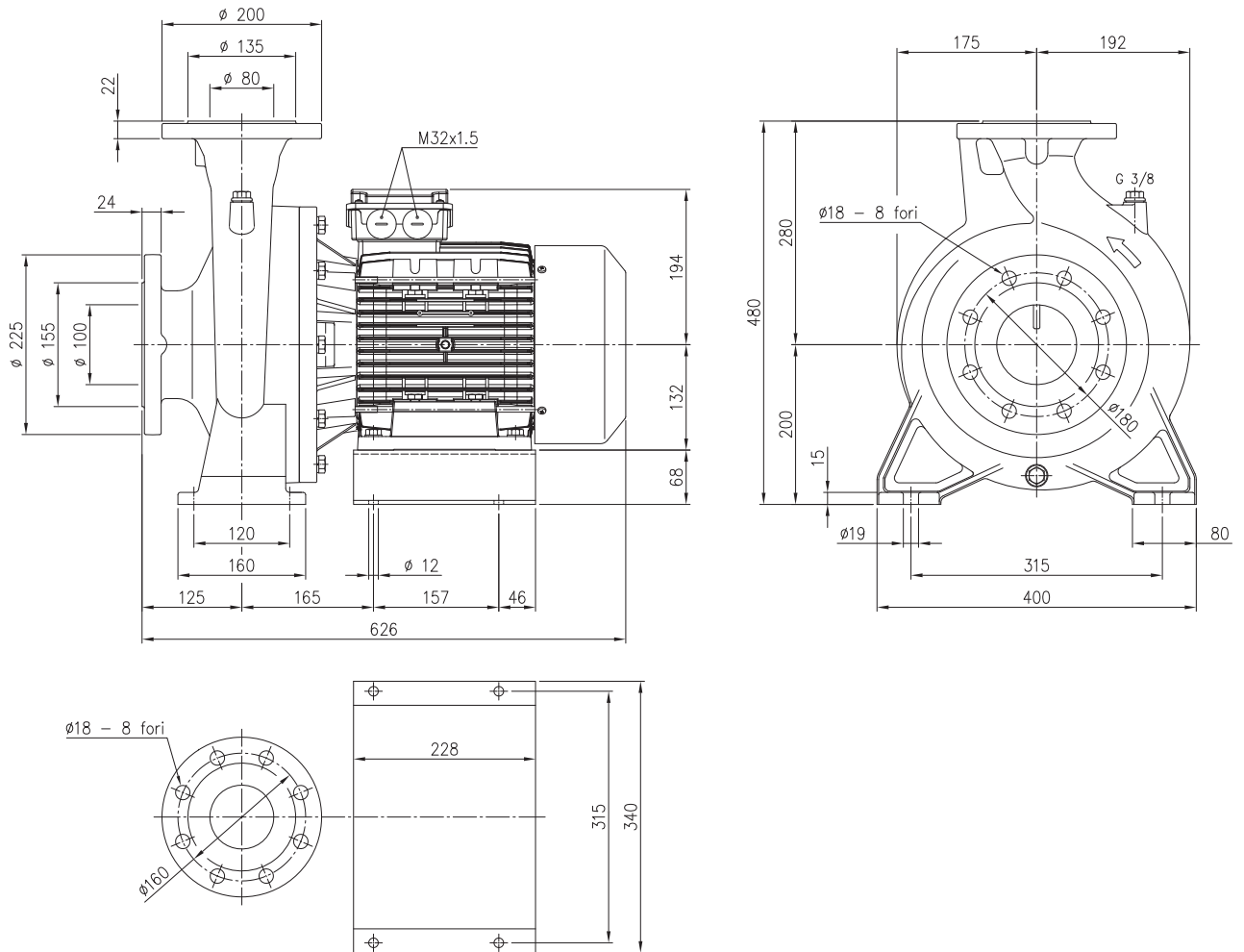

Weight: 119 kgf

PUMP 3(.)S4 32, 40, 50, 65-125/160

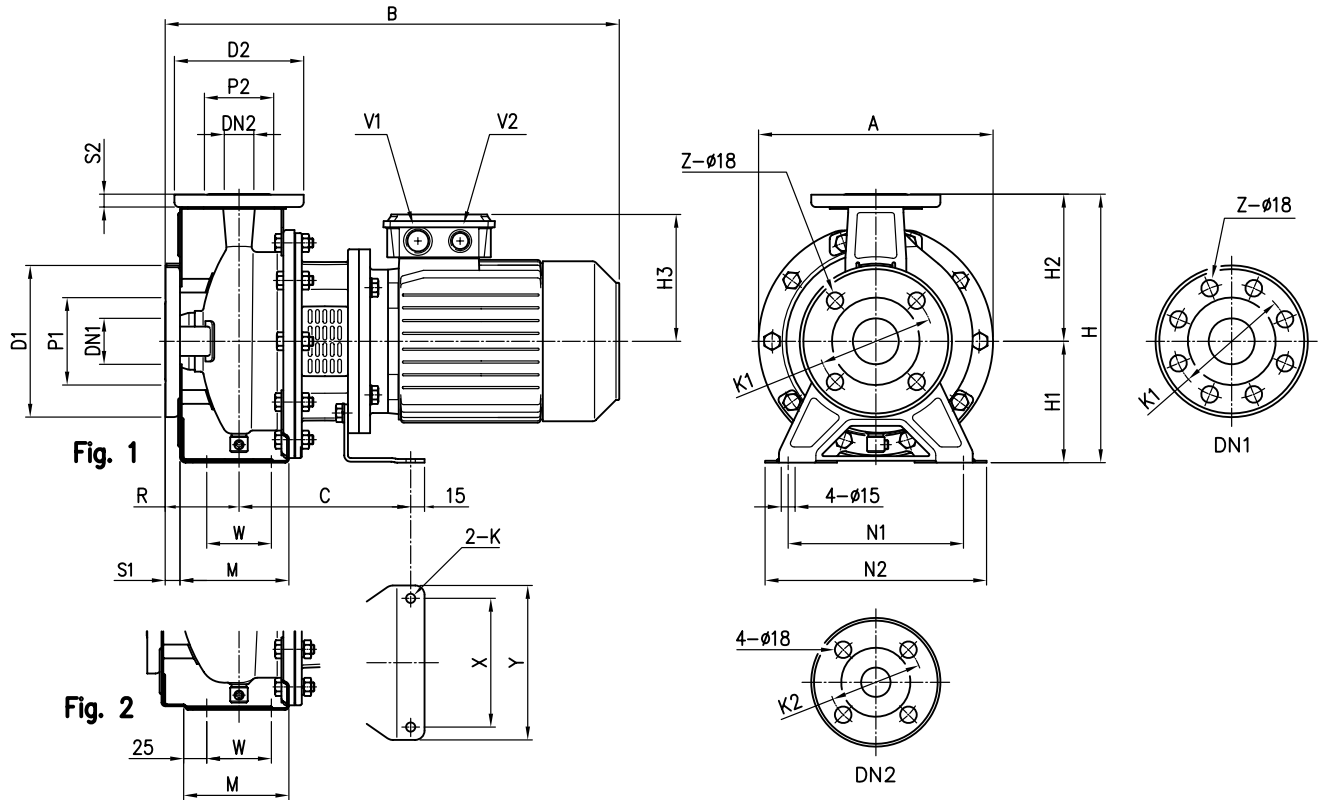

Pump type	Dimensions (mm)																												Weight [kgf] (*)				
	Ø DN1	Ø P1	Ø K1	Ø D1	S1	Z	[1]	[2]	Ø DN2	Ø P2	Ø K2	Ø D2	S2	Fig.	H	H1	H2	H3	R	W	M	N1	N2	A	B	C	X	Y	K	V1	V2		
32-125/0.25	50	95	125	165	16	4	-	-	32	75	100	140	14	1	252	112	140	114	80	70	114	140	190	213	404	153	112	140	8	M20x1.5	M16x1.5	15.4	-
32-160/0.37R	50	95	125	165	16	4	-	-	32	75	100	140	14	1	292	132	160	114	80	70	118	190	240	254	404	153	112	140	8	M20x1.5	M16x1.5	18.5	-
32-160/0.37	50	95	125	165	16	4	-	-	32	75	100	140	14	1	292	132	160	114	80	70	118	190	240	254	404	153	112	140	8	M20x1.5	M16x1.5	18.7	-
32-200/0.55R	50	95	125	165	16	4	-	-	32	75	100	140	14	1	340	160	180	139	80	70	119	190	240	296	430	174	140	168	10	M25x1.5	M20x1.5	28	-
32-200/0.55	50	95	125	165	16	4	-	-	32	75	100	140	14	1	340	160	180	139	80	70	119	190	240	296	430	174	140	168	10	M25x1.5	M20x1.5	33	-
32-200/0.75	50	95	125	165	16	4	-	-	32	75	100	140	14	1	340	160	180	139	80	70	119	190	240	296	430	174	140	168	10	M25x1.5	M20x1.5	29.5	29.5
40-125/0.37R	65	115	145	185	16	4	-	-	40	80	110	150	14	1	252	112	140	114	80	70	114	160	210	213	404	153	112	140	8	M20x1.5	M16x1.5	16.2	-
40-125/0.37	65	115	145	185	16	4	-	-	40	80	110	150	14	1	252	112	140	114	80	70	114	160	210	213	404	153	112	140	8	M20x1.5	M16x1.5	16.2	-
40-160/0.55R	65	115	145	185	16	4	-	-	40	80	110	150	14	1	292	132	160	139	80	70	118	190	240	254	430	174	140	168	10	M25x1.5	M20x1.5	23.5	-
40-160/0.55	65	115	145	185	16	4	-	-	40	80	110	150	14	1	292	132	160	139	80	70	118	190	240	254	430	174	140	168	10	M25x1.5	M20x1.5	23.5	-
40-200/1.1R	65	115	145	185	16	4	-	-	40	80	110	150	14	2	340	160	180	148	100	70	115	212	265	296	497	186	140	168	10	M25x1.5	M20x1.5	34.3	32.1
40-200/1.1	65	115	145	185	16	4	-	-	40	80	110	150	14	2	340	160	180	148	100	70	115	212	265	296	497	186	140	168	10	M25x1.5	M20x1.5	34.3	32.1
40-200/1.5	65	115	145	185	16	4	-	-	40	80	110	150	14	2	340	160	180	148	100	70	115	212	265	296	497	186	140	168	10	M25x1.5	M20x1.5	35.5	32.9
50-125/0.55R	65	115	145	185	16	4	-	-	50	95	125	165	16	2	292	132	160	139	100	70	114	190	240	254	450	174	140	168	10	M25x1.5	M20x1.5	23.7	-
50-125/0.55	65	115	145	185	16	4	-	-	50	95	125	165	16	2	292	132	160	139	100	70	114	190	240	254	450	174	140	168	10	M25x1.5	M20x1.5	23.7	-
50-160/1.1R	65	115	145	185	16	4	-	-	50	95	125	165	16	2	340	160	180	148	100	70	115	212	265	296	497	186	140	168	10	M25x1.5	M20x1.5	34	31.8
50-160/1.1	65	115	145	185	16	4	-	-	50	95	125	165	16	2	340	160	180	148	100	70	115	212	265	296	497	186	140	168	10	M25x1.5	M20x1.5	34	31.8
50-200/1.5R	65	115	145	185	16	4	-	-	50	95	125	165	16	2	360	160	200	148	100	70	115	212	265	296	497	186	140	168	10	M25x1.5	M20x1.5	37.1	34.5
50-200/1.5	65	115	145	185	16	4	-	-	50	95	125	165	16	2	360	160	200	148	100	70	115	212	265	296	497	186	140	168	10	M25x1.5	M20x1.5	37.1	34.5
65-125/0.55	80	134	160	200	18	8	4	65	115	145	185	16	2	340	160	180	139	100	95	140	212	280	254	450	174	140	168	10	M25x1.5	M20x1.5	21.5	-	
65-125/0.75	80	134	160	200	18	8	4	65	115	145	185	16	2	340	160	180	139	100	95	140	212	280	254	450	174	140	168	10	M25x1.5	M20x1.5	30	30	
65-125/1.1	80	134	160	200	18	8	4	65	115	145	185	16	2	340	160	180	148	100	95	140	212	280	254	497	186	140	168	10	M25x1.5	M20x1.5	30	27.8	
65-160/1.1	80	134	160	200	18	8	4	65	115	145	185	16	2	360	160	200	148	100	95	140	212	280	296	497	186	140	168	10	M25x1.5	M20x1.5	31	28.8	
65-160/1.5	80	134	160	200	18	8	4	65	115	145	185	16	2	360	160	200	148	100	95	140	212	280	296	497	186	140	168	10	M25x1.5	M20x1.5	43	40.4	

[1] Standard [2] On request (*) Only for IE3 Motors

PUMP 3LS4 65-250, 80-160/200/250

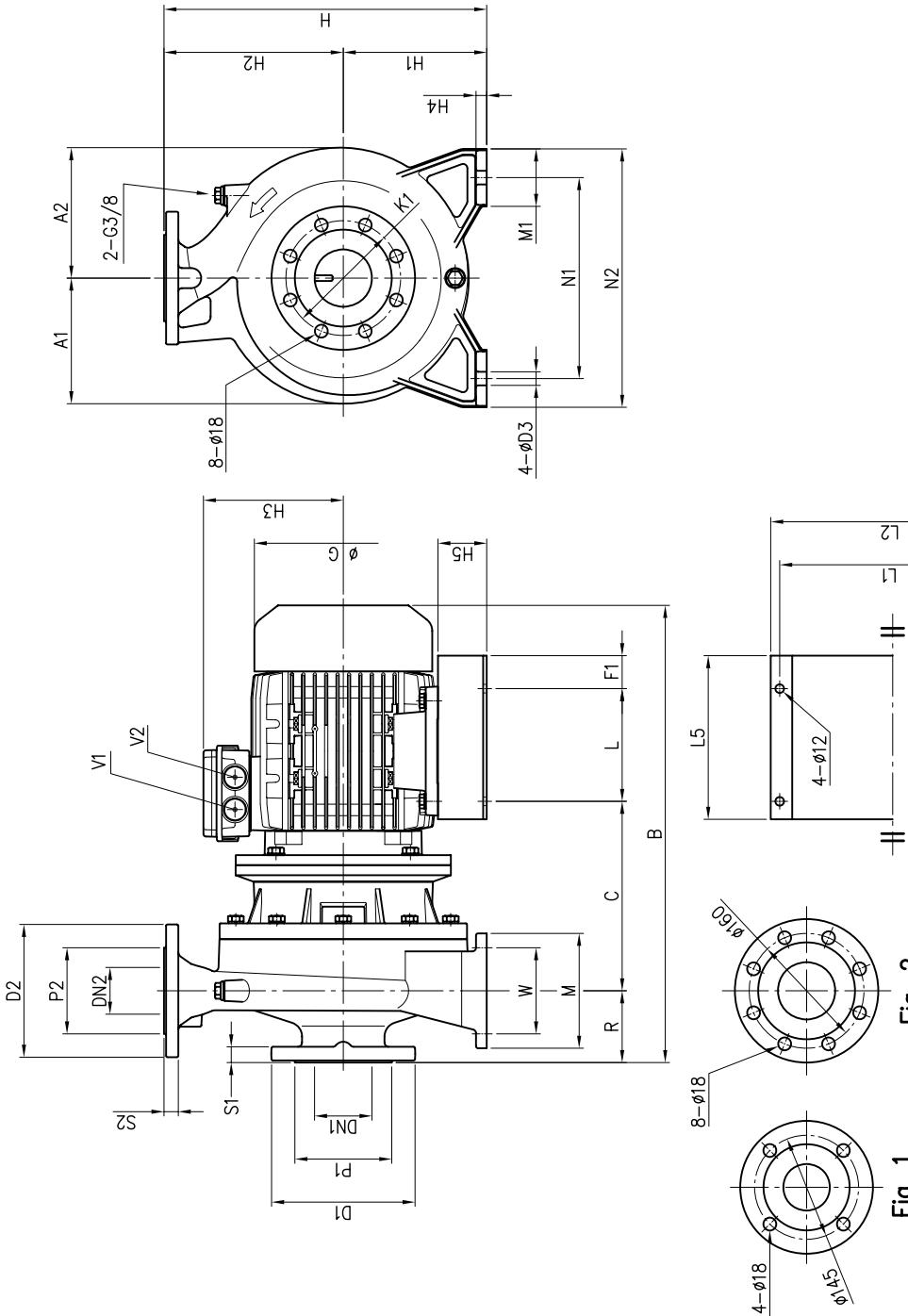

Pump type	Dimensions [mm]																				Weight [kgf]															
	DN1	P1	K1	D1	S1	DN2	P2	D2	S2	H	H1	H2	H3	H4	H5	R	W	N1	N2	M	M1	L	L1	L2	L5	A1	A2	B	C	F1	G	D3	V1	V2	Weight [kgf]	(*)
65-250/4	80	135	160	200	22	65 Fig. 1	120	185	20	450	200	250	171	15	88	100	120	280	360	160	80	147	265	290	187	175	182	580	215	20	225	19	M20x1.5	M20x1.5	85	90.6
65-250/5.5	80	135	160	200	22	65 Fig. 1	120	185	20	450	200	250	198	15	68	100	120	280	360	160	80	157	315	340	228	175	182	637	264	46	248	19	M32x1.5	M32x1.5	108	118
80-160/2.2R	100	155	180	225	24	80 Fig. 2	135	200	22	405	180	225	155	13	80	125	95	250	320	125	65	140	250	275	190	147	173	573	205	25	196	15	M25x1.5	M20x1.5	69.7	70.1
80-160/2.2	100	155	180	225	24	80 Fig. 2	135	200	22	405	180	225	155	13	80	125	95	250	320	125	65	140	250	275	190	147	173	573	205	25	196	15	M25x1.5	M20x1.5	70	70.4
80-200/3	100	155	180	225	24	80 Fig. 2	135	200	22	430	180	250	135	13	80	125	95	280	345	125	65	140	250	275	190	175	182	583	215	25	196	15	M25x1.5	M20x1.5	80	80
80-200/4R	100	155	180	225	24	80 Fig. 2	135	200	22	430	180	250	161	13	68	125	95	280	345	125	65	157	315	340	228	175	182	605	198	46	225	15	M25x1.5	M20x1.5	84	89.6
80-200/4	100	155	180	225	24	80 Fig. 2	135	200	22	430	180	250	161	13	68	125	95	280	345	125	65	157	315	340	228	175	182	605	198	46	225	15	M25x1.5	M20x1.5	90	95.6
80-250/5.5R	100	155	180	225	24	80 Fig. 2	135	200	22	480	200	280	198	15	68	125	120	315	400	160	80	157	315	340	228	175	192	662	264	46	248	19	M32x1.5	M32x1.5	114	124
80-250/5.5	100	155	180	225	24	80 Fig. 2	135	200	22	480	200	280	198	15	68	125	120	315	400	160	80	157	315	340	228	175	192	662	264	46	248	19	M32x1.5	M32x1.5	115	125
80-250/7.5	100	155	180	225	24	80 Fig. 2	135	200	22	480	200	280	198	15	68	125	120	315	400	160	80	157	315	340	228	175	192	722	264	46	248	19	M32x1.5	M32x1.5	-	134

[1] Standard [2] On request (*) Only for IE3 Motors

PUMP 3LS4 80-160/1.5

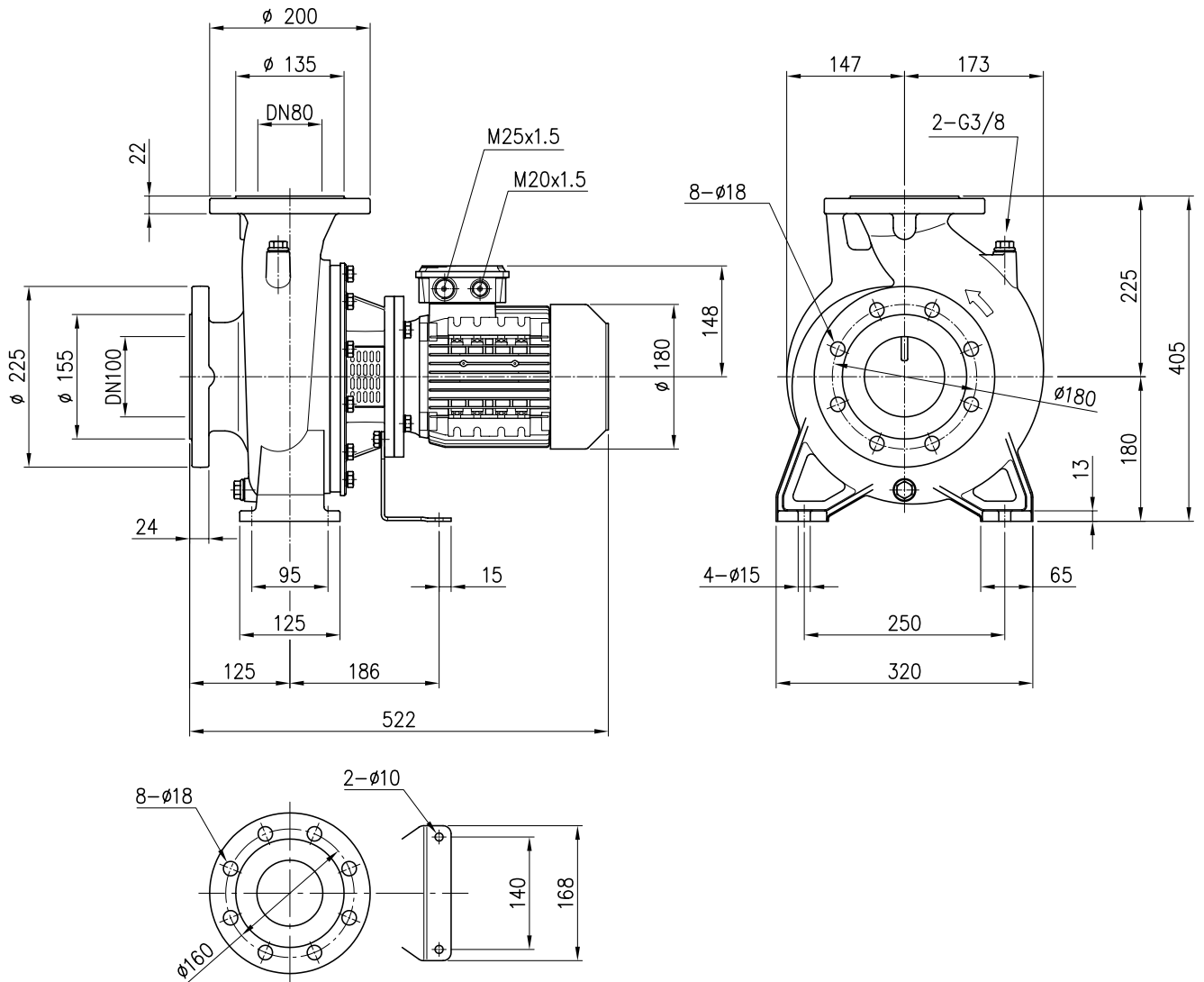

Weight: 60.5 kgf
 Weight only for IE3 Motors: 57.9 kgf

PUMP 3(.)P4 32, 40, 50, 65-125/160/200

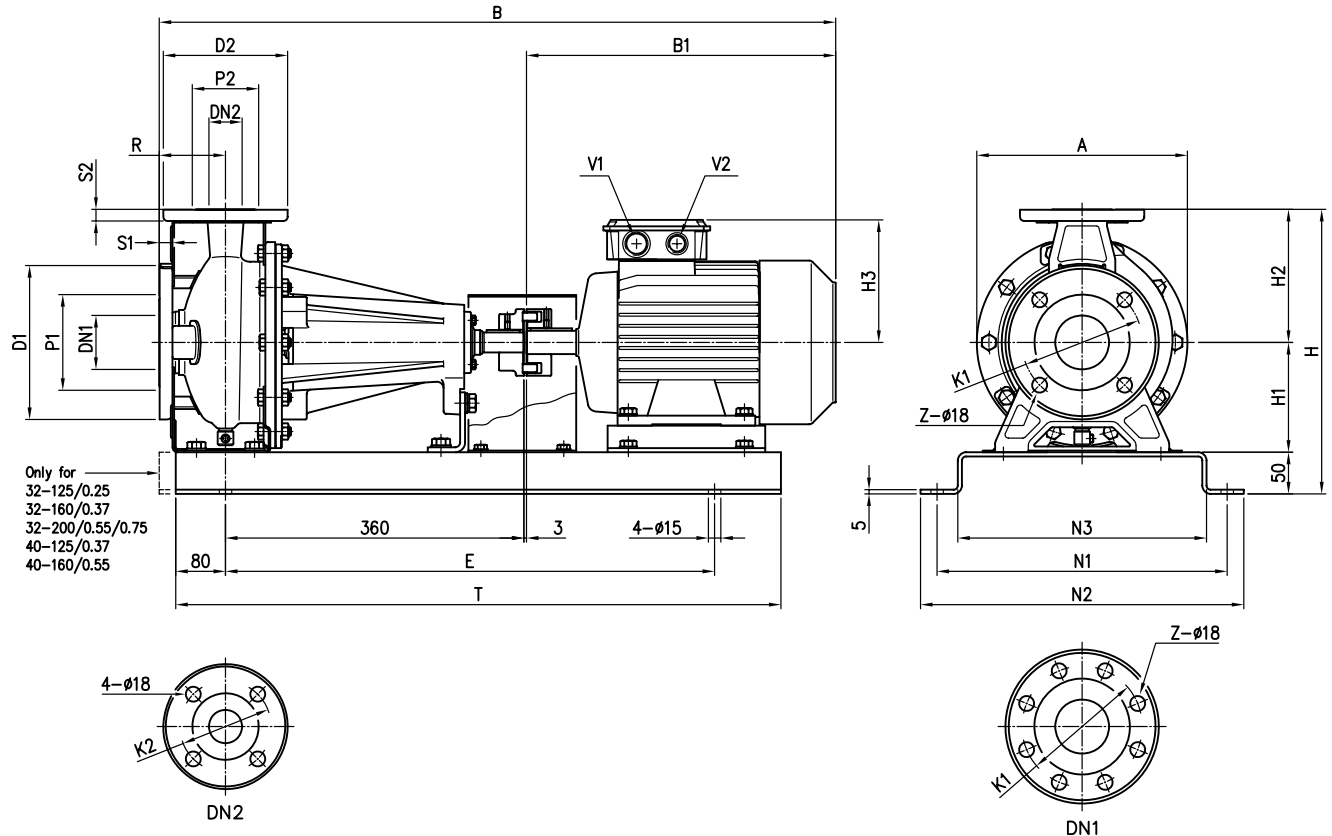

Pump type	Dimensions [mm]																							Weight [kgf]					
	Ø DN1	Ø P1	Ø K1	Ø D1	S1	Z	Ø [1]	Ø [2]	Ø DN2	Ø P2	Ø K2	Ø D2	Ø D4	S2	H	H1	H2	H3	R	A	B	B1	E	N1	N2	N3	T	V1	V2
3P 32-125/0.25	50	95	125	165	16	4	-	32	75	100	140	14	302	112	140	114	80	213	689	246	550	300	340	250	710	M20x1.5	M16x1.5	37	-
3P 32-160/0.37R	50	95	125	165	16	4	-	32	75	100	140	14	342	132	160	114	80	254	689	246	510	350	390	300	670	M20x1.5	M16x1.5	41	-
3P 32-160/0.37	50	95	125	165	16	4	-	32	75	100	140	14	342	132	160	114	80	254	689	246	510	350	390	300	670	M20x1.5	M16x1.5	41	-
3P 32-200/0.55R	50	95	125	165	16	4	-	32	75	100	140	14	390	160	180	139	80	296	715	272	510	350	390	300	670	M25x1.5	M20x1.5	53.5	-
3P 32-200/0.55	50	95	125	165	16	4	-	32	75	100	140	14	390	160	180	139	80	296	715	272	510	350	390	300	670	M25x1.5	M20x1.5	53.5	-
3P 32-200/0.75	50	95	125	165	16	4	-	32	75	100	140	14	390	160	180	139	80	296	715	272	510	350	390	300	670	M25x1.5	M20x1.5	54.5	54.5
3P 40-125/0.37R	65	115	145	185	16	4	-	40	80	110	150	14	302	112	140	114	80	213	689	246	550	300	340	250	710	M20x1.5	M16x1.5	46.5	-
3P 40-125/0.37	65	115	145	185	16	4	-	40	80	110	150	14	302	112	140	114	80	213	689	246	550	300	340	250	710	M20x1.5	M16x1.5	46.5	-
3P 40-160/0.55R	65	115	145	185	16	4	-	40	80	110	150	14	342	132	160	139	80	254	715	272	510	350	390	300	670	M25x1.5	M20x1.5	44.5	-
3P 40-160/0.55	65	115	145	185	16	4	-	40	80	110	150	14	342	132	160	139	80	254	715	272	510	350	390	300	670	M25x1.5	M20x1.5	44.5	-
3P 40-200/1.1R	65	115	145	185	16	4	-	40	80	110	150	14	390	160	180	148	100	296	780	317	590	350	390	300	750	M25x1.5	M20x1.5	61.5	59.3
3P 40-200/1.1	65	115	145	185	16	4	-	40	80	110	150	14	390	160	180	148	100	296	780	317	590	350	390	300	750	M25x1.5	M20x1.5	61.5	59.3
3P 40-200/1.5	65	115	145	185	16	4	-	40	80	110	150	14	390	160	180	148	100	296	780	317	590	350	390	300	750	M25x1.5	M20x1.5	64	61.4
3P 50-125/0.55R	65	115	145	185	16	4	-	50	95	125	165	16	342	132	160	139	100	254	735	272	510	350	390	300	670	M25x1.5	M20x1.5	45	-
3P 50-125/0.55	65	115	145	185	16	4	-	50	95	125	165	16	342	132	160	139	100	254	735	272	510	350	390	300	670	M25x1.5	M20x1.5	45	-
3P 50-160/1.1R	65	115	145	185	16	4	-	50	95	125	165	16	390	160	180	148	100	296	780	317	590	350	390	300	750	M25x1.5	M20x1.5	52.5	50.3
3P 50-160/1.1	65	115	145	185	16	4	-	50	95	125	165	16	390	160	180	148	100	296	780	317	590	350	390	300	750	M25x1.5	M20x1.5	52.5	50.3
3P 50-200/1.5R	65	115	145	185	16	4	-	50	95	125	165	16	410	160	200	148	100	296	780	317	590	350	390	300	750	M25x1.5	M20x1.5	64	61.4
3P 50-200/1.5	65	115	145	185	16	4	-	50	95	125	165	16	410	160	200	148	100	296	780	317	590	350	390	300	750	M25x1.5	M20x1.5	64	61.4
3P 50-200/2.2	65	115	145	185	16	4	-	50	95	125	165	16	410	160	200	155	100	296	829	366	590	350	390	300	750	M25x1.5	M20x1.5	70	70.4
3P 65-125/0.55	80	134	160	200	18	8	4	65	115	145	185	16	390	160	180	139	100	254	735	272	510	350	390	300	670	M25x1.5	M20x1.5	48.5	-
3P 65-125/0.75	80	134	160	200	18	8	4	65	115	145	185	16	390	160	180	139	100	254	735	272	510	350	390	300	670	M25x1.5	M20x1.5	48.5	48.5
3P 65-125/1.1	80	134	160	200	18	8	4	65	115	145	185	16	390	160	180	148	100	254	780	317	590	350	390	300	750	M25x1.5	M20x1.5	56	53.8
3P 65-160/1.1	80	134	160	200	18	8	4	65	115	145	185	16	410	160	200	148	100	296	780	317	590	350	390	300	750	M25x1.5	M20x1.5	62.5	60.3
3P 65-160/1.5	80	134	160	200	18	8	4	65	115	145	185	16	410	160	200	148	100	296	780	317	590	350	390	300	750	M25x1.5	M20x1.5	63.5	60.9
3P 65-160/2.2	80	134	160	200	18	8	4	65	115	145	185	16	410	160	200	155	100	296	829	366	590	350	390	300	750	M25x1.5	M20x1.5	71.5	71.9
3P 65-200/2.2R	80	134	160	200	18	8	4	65	115	145	185	16	455	180	225	155	100	296	829	366	590	380	420	330	750	M25x1.5	M20x1.5	74	74.4
3P 65-200/2.2	80	134	160	200	18	8	4	65	115	145	185	16	455	180	225	155	100	296	829	366	590	380	420	330	750	M25x1.5	M20x1.5	74	74.4
3P 65-200/3	80	134	160	200	18	8	4	65	115	145	185	16	455	180	225	155	100	296	829	366	590	380	420	330	750	M25x1.5	M20x1.5	77.5	77.5

[1] Standard [2] On request (*) Only for IE3 Motors

PUMP 3LP4 65-250, 80

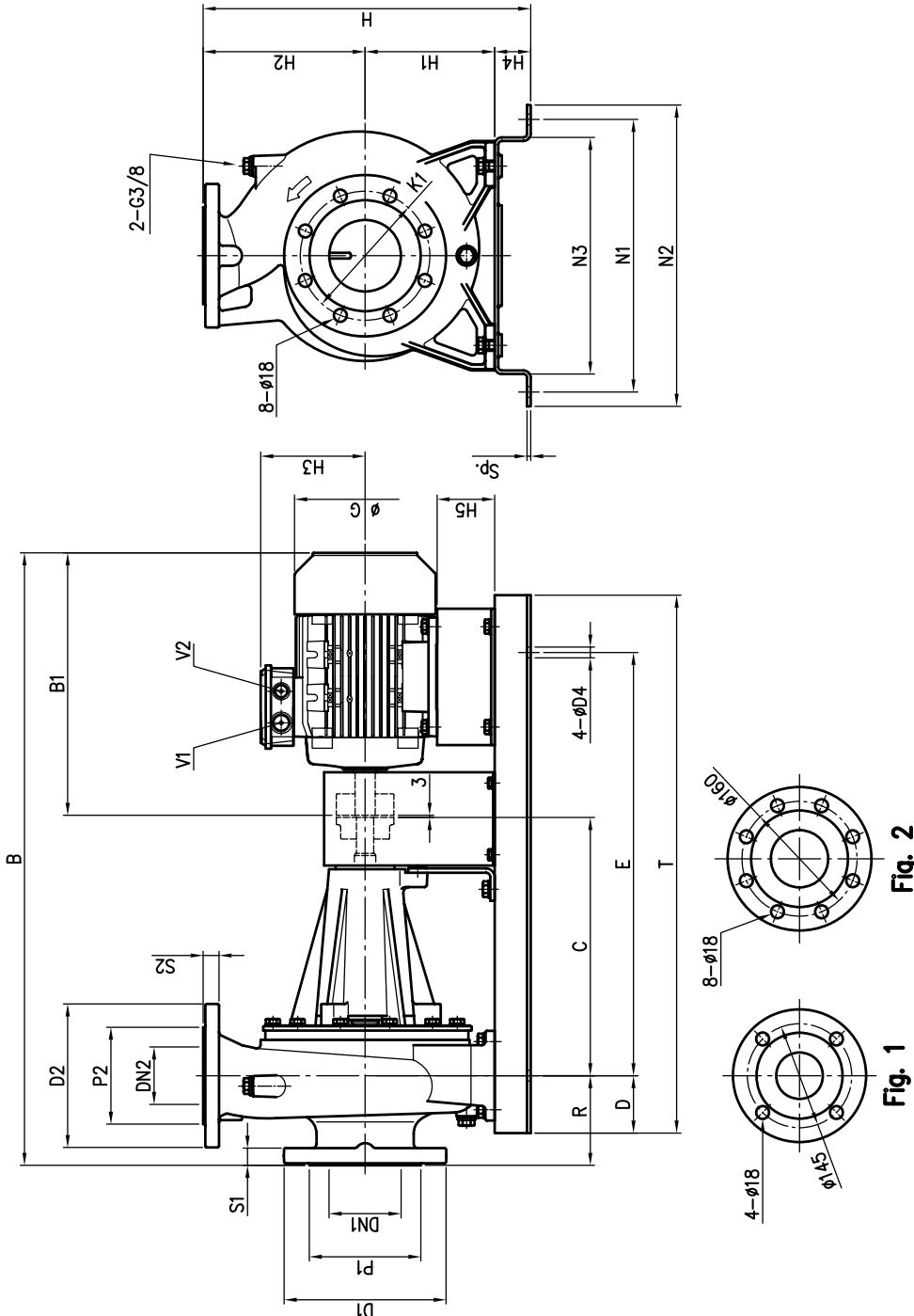

Pump type	Dimensions [mm]																				Weight [kgf]										
	DN1	P1	D1	S1	DN2	P2	D2	S2	H	H1	H2	H3	H4	H5	R	N1	N2	N3	B	B1	C	D	G	E	T	D4	Sp.	V1	V2	Weight	(*)
65-250/4	80	135	200	22	65 Fig. 1	120	185	20	510	200	250	171	60	88	100	510	570	440	961	388	470	100	225	760	960	19	8	M25x1.5	M20x1.5	113.5	119.1
65-250/5.5	80	135	200	22	65 Fig. 1	120	185	20	510	200	250	198	60	88	100	510	570	440	1015	442	470	100	248	760	960	19	8	M32x1.5	M32x1.5	130	140
80-160/1.5	100	155	225	24	80 Fig. 2	135	200	22	455	180	225	148	50	90	125	380	420	330	805	317	360	80	180	590	750	15	5	M25x1.5	M20x1.5	80	77.4
80-160/2.2R	100	155	225	24	80 Fig. 2	135	200	22	455	180	225	155	50	80	125	380	420	330	854	366	360	80	196	590	750	15	5	M25x1.5	M20x1.5	86	86.4
80-160/2.2	100	155	225	24	80 Fig. 2	135	200	22	455	180	225	155	50	80	125	380	420	330	854	366	360	80	196	590	750	15	5	M25x1.5	M20x1.5	100.5	100.9
80-200/3	100	155	225	24	80 Fig. 2	135	200	22	490	180	250	155	60	80	125	460	520	390	964	386	470	100	196	700	900	19	8	M25x1.5	M20x1.5	108.5	109.5
80-200/4R	100	155	225	24	80 Fig. 2	135	200	22	490	180	250	171	60	88	125	460	520	390	986	388	470	100	225	700	900	19	8	M25x1.5	M20x1.5	116.5	122.1
80-200/4	100	155	225	24	80 Fig. 2	135	200	22	490	180	250	171	60	88	125	460	520	390	986	388	470	100	225	700	900	19	8	M25x1.5	M20x1.5	117	122.6
80-250/5.5R	100	155	225	24	80 Fig. 2	135	200	22	540	200	280	198	60	88	125	510	570	440	1040	442	470	100	248	760	960	19	8	M32x1.5	M32x1.5	134	144
80-250/5.5	100	155	225	24	80 Fig. 2	135	200	22	540	200	280	198	60	88	125	510	570	440	1040	442	470	100	248	760	960	19	8	M32x1.5	M32x1.5	134.5	144.5
80-250/7.5	100	155	225	24	80 Fig. 2	135	200	22	540	200	280	198	60	88	125	510	570	440	1100	502	470	100	248	760	960	19	8	M32x1.5	M32x1.5	-	157.5

[1] Standard [2] On request (*) Only for IE3 Motors

PACKING 3(.)M4

Pump type	Packing [mm]			Weight [kgf]	Pack type		
	Z	X	Y				
32-125/0.25	450	250	300	18.1	1		
32-160/0.37R	430	280	340	21.5			
32-160/0.37				22.1			
32-200/0.55R	500	330	390	26.4			
32-200/0.55				26.4			
32-200/0.75				31			
40-125/0.37R	450	250	300	16.9			
40-125/0.37				17			
40-160/0.55R	430	280	340	23.3			
40-160/0.55				23.4			
40-200/1.1R	500	330	390	31.7			
40-200/1.1				31.8			
40-200/1.5				580	350	416	33
50-125/0.55R	430	280	340	22.5			
50-125/0.55				22.6			
50-160/1.1R	500	330	390	31.5			
50-160/1.1				31.6			
50-200/1.5R				32.7			
50-200/1.5				33.8			
50-200/2.2	580	350	416	32.7			
65-125/0.55	500	330	390	24.3			
65-125/0.75				22			
65-125/1.1				26.5			
65-160/1.1				31			
65-160/1.5	580	350	416	34			
65-160/2.2	500	330	390	35			
65-200/2.2R	600	390	533	35			
65-200/2.2				35			
65-200/3				40			
65-250/4				760	455	613	92
65-250/5.5	760	455	613	106			
80-160/1.5				580	370	538	58
80-160/2.2R							58
80-160/2.2							58
80-200/3							78
80-250/4R				760	455	613	85
80-250/4							86
80-250/5.5R							99
80-250/5.5							103
80-250/7.5							124

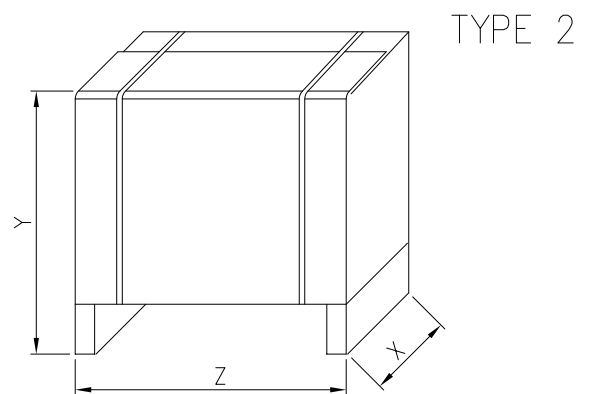
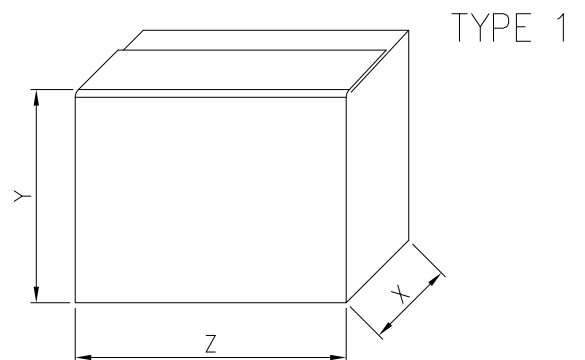

PACKING 3(.)S4

Pump type	Packing [mm]			Weight [kgf]		Pack type			
	Z	X	Y		(*)				
32-125/0.25	450	250	300	17.5	-	1			
32-160/0.37R	490	280	340	21.5	-				
32-160/0.37	430	280	330	21.3	-				
32-200/0.55R	500	330	390	30.1	-				
32-200/0.55				34.3	-				
32-200/0.75				32.3	32.3				
40-125/0.37R	450	250	300	18.5	-	2			
40-125/0.37	490	280	340	18.8	-				
40-160/0.55R				25.5	-				
40-160/0.55	700	350	498	25.6	-				
40-200/1.1R				35.4	33.2				
40-200/1.1				35.4	33.2				
40-200/1.5	490	280	340	40.7	38.1	1			
50-125/0.55R				25.9	-				
50-125/0.55				25.9	-				
50-160/1.1R				700	350		498	40	37.8
50-160/1.1								40	37.8
50-200/1.5R								38.6	36
50-200/1.5	38.6	36							
50-200/2.2	47.5	47.9							
65-125/0.55	580	350	488	28	-	2			
65-125/0.75				33	33				
65-125/1.1				37.1	34.9				
65-160/1.1				39	36.8				
65-160/1.5				40	37.4				
65-160/2.2				45	45.4				
65-200/2.2R	600	390	533	50	50.4				
65-200/2.2				50	50.4				
65-200/3				50	50				
65-250/4				760	455	613	95	10.6	
65-250/5.5	116	126							
80-160/1.5	580	370	538				69.5	66.9	
80-160/2.2R	680			75.5	75.9				
80-160/2.2				76	76.4				
80-200/3	760	455	613	88	88				
80-200/4R				94	99.6				
80-200/4				97	102.6				
80-250/5.5R				124	134				
80-250/5.5				125	135				
80-250/7.5				-	-	144			

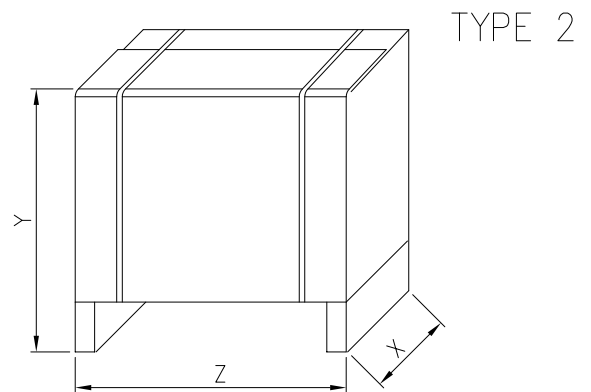
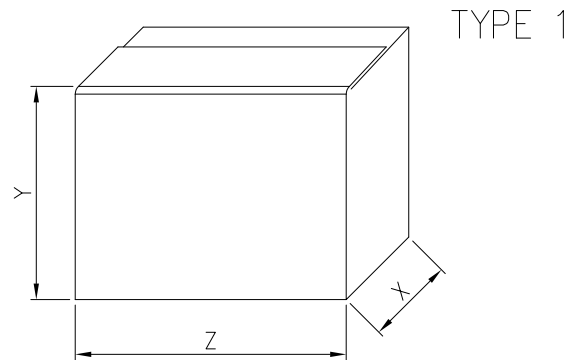

(*) Only for IE3 Motors

PACKING 3(.)P4

Pump type	Packing [mm]			Weight [kgf]		
	Z	X	Y		(*)	
32-125/0.25	1200	800	394	37	-	
32-160/0.37R			434	41	-	
32-160/0.37				41	-	
32-200/0.55R			482	53.5	-	
32-200/0.55				53.5	-	
32-200/0.75				54.5	54.5	
40-125/0.37R			394	46.5	-	
40-125/0.37				46.5	-	
40-160/0.55R			434	44.5	-	
40-160/0.55				44.5	-	
40-200/1.1R			482	61.5	59.3	
40-200/1.1				61.5	59.3	
40-200/1.5				64	61.4	
50-125/0.55R			434	45	-	
50-125/0.55				45	-	
50-160/1.1R			482	52.5	50.3	
50-160/1.1				52.5	50.3	
50-200/1.5R			502	64	61.4	
50-200/1.5				64	61.4	
50-200/2.2				70	70.4	
65-125/0.55			482	48.5	-	
65-125/0.75				50	50	
65-125/1.1				56	53.8	
65-160/1.1				62.5	60.3	
65-160/1.5				502	63.5	60.9
65-160/2.2					71.5	71.9
65-200/2.2R				547	74	74.4
65-200/2.2					74	74.4
65-200/3					77.5	77.5
65-250/4				635	113.5	119.1
65-250/5.5			130		140	
80-160/1.5			580		80	77.4
80-160/2.2R	86	83.4				
80-160/2.2	100.5	97.9				
80-200/3	109.5	109.5				
80-200/4R	615	116.5		122.1		
80-200/4		117		122.6		
80-250/5.5R	665	134		144		
80-250/5.5		134.5		144.5		
80-250/7.5		-		157.5		

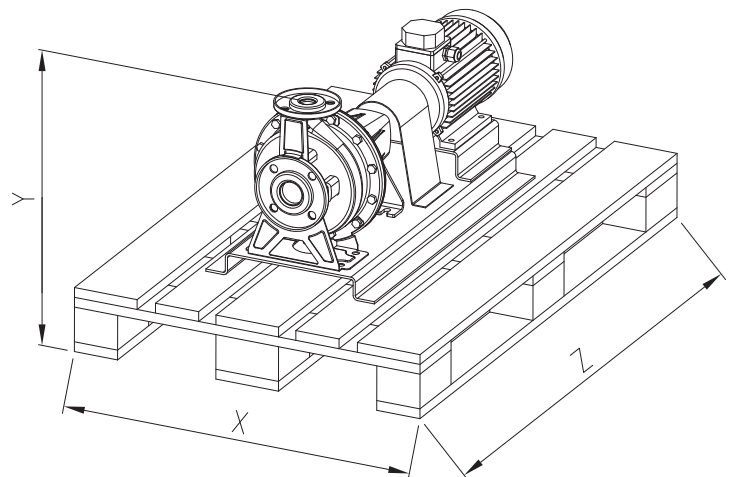

(*) Only for IE3 Motors

MOTOR DATA 3(.)M4

Pump type	Motor			Efficiency	Input [kW]	Efficiency (% load) and power-factor				Full load current [A]			Locked rotor current [A]		
	Motor Size	Power				50%	75%	100%	cos-φ	230 V	400 V	690 V	230 V	400 V	690 V
		[kW]	[HP]												
3(.)M4 32-125/0.25	71	0.25	0.33	-	0.55	-	-	-	-	1.9	1.1	-	7.3	4.2	-
3(.)M4 32-160/0.37R	80	0.37	0.5	-	0.80	-	-	-	-	2.6	1.5	-	9.9	5.7	-
3(.)M4 32-160/0.37		0.37	0.5	-	0.80	-	-	-	-	2.6	1.5	-	9.9	5.7	-
3(.)M4 32-200/0.55R	80	0.55	0.75	-	0.80	-	-	-	-	2.6	1.5	-	9.9	5.7	-
3(.)M4 32-200/0.55		0.55	0.75	-	0.80	-	-	-	-	2.6	1.5	-	9.9	5.7	-
3(.)M4 32-200/0.75	90	0.75	1	IE3	1.31	81.5	83.4	84.1	0.71	4.6	2.7	-	32.9	19.0	-
3(.)M4 40-125/0.37R	71	0.37	0.5	-	0.55	-	-	-	-	1.9	1.1	-	7.3	4.2	-
3(.)M4 40-125/0.37		0.37	0.5	-	0.55	-	-	-	-	1.9	1.1	-	7.3	4.2	-
3(.)M4 40-160/0.55R	80	0.55	0.75	-	0.80	-	-	-	-	2.6	1.5	-	9.9	5.7	-
3(.)M4 40-160/0.55		0.55	0.75	-	0.80	-	-	-	-	2.6	1.5	-	9.9	5.7	-
3(.)M4 40-200/1.1R	90	1.1	1.5	IE3	1.31	81.5	83.4	84.1	0.71	4.6	2.7	-	32.9	19.0	-
3(.)M4 40-200/1.1		1.1	1.5	IE3	1.31	81.5	83.4	84.1	0.71	4.6	2.7	-	32.9	19.0	-
3(.)M4 40-200/1.5		1.5	2	IE3	1.76	81.1	84.1	85.3	0.71	6.2	3.6	-	45.0	26.0	-
3(.)M4 50-125/0.55R	80	0.55	0.75	-	0.80	-	-	-	-	2.6	1.5	-	9.9	5.7	-
3(.)M4 50-125/0.55		0.55	0.75	-	0.80	-	-	-	-	2.6	1.5	-	9.9	5.7	-
3(.)M4 50-160/1.1R	90	1.1	1.5	IE3	1.31	81.5	83.4	84.1	0.71	4.6	2.7	-	32.9	19.0	-
3(.)M4 50-160/1.1		1.1	1.5	IE3	1.31	81.5	83.4	84.1	0.71	4.6	2.7	-	32.9	19.0	-
3(.)M4 50-200/1.5R		1.5	2	IE3	1.76	81.1	84.1	85.3	0.71	6.2	3.6	-	45.0	26.0	-
3(.)M4 50-200/1.5		1.5	2	IE3	1.76	81.1	84.1	85.3	0.71	6.2	3.6	-	45.0	26.0	-
3(.)M4 50-200/2.2	100	2.2	3	IE3	2.54	86.1	87.0	86.7	0.78	7.8	4.5	-	53.7	31.0	-
3(.)M4 65-125/0.55	80	0.55	0.75	-	0.80	-	-	-	-	2.6	1.5	-	9.9	5.7	-
3(.)M4 65-125/0.75	90	0.75	1	IE3	1.31	81.5	83.4	84.1	0.71	4.6	2.7	-	32.9	19.0	-
3(.)M4 65-125/1.1		1.1	1.5	IE3	1.31	81.5	83.4	84.1	0.71	4.6	2.7	-	32.9	19.0	-
3(.)M4 65-160/1.1		1.1	1.5	IE3	1.31	81.5	83.4	84.1	0.71	4.6	2.7	-	32.9	19.0	-
3(.)M4 65-160/1.5		1.5	2	IE3	1.76	81.1	84.1	85.3	0.71	6.2	3.6	-	45.0	26.0	-
3(.)M4 65-160/2.2	100	2.2	3	IE3	2.54	86.1	87.0	86.7	0.78	7.8	4.5	-	53.7	31.0	-
3(.)M4 65-200/2.2R		2.2	3	IE3	2.54	86.1	87.0	86.7	0.78	7.8	4.5	-	53.7	31.0	-
3(.)M4 65-200/2.2		2.2	3	IE3	2.54	86.1	87.0	86.7	0.78	7.8	4.5	-	53.7	31.0	-
3(.)M4 65-200/3		3	4	IE3	3.42	85.7	87.7	87.8	0.72	11.8	6.8	-	83.1	48.0	-
3LM4 65-250/4	112	4	5.5	IE3	4.51	85.8	87.6	88.6	0.76	14.4	8.3	-	103.9	60.0	-
3LM4 65-250/5.5	132	5.5	7.5	IE3	6.14	87.2	88.5	89.6	0.78	-	10.9	6.3	-	120.0	69.6
3LM4 80-160/1.5	90	1.5	2	IE3	1.76	81.1	84.1	85.3	0.71	6.2	3.6	-	45.0	26.0	-
3LM4 80-160/2.2R	100	2.2	3	IE3	2.54	86.1	87.0	86.7	0.78	7.8	4.5	-	53.7	31.0	-
3LM4 80-160/2.2		2.2	3	IE3	2.54	86.1	87.0	86.7	0.78	7.8	4.5	-	53.7	31.0	-
3LM4 80-200/3		3	4	IE3	3.42	85.7	87.7	87.8	0.72	11.8	6.8	-	83.1	48.0	-
3LM4 80-200/4R	112	4	5.5	IE3	4.51	85.8	87.6	88.6	0.76	14.4	8.3	-	103.9	60.0	-
3LM4 80-200/4	112	4	5.5	IE3	4.51	85.8	87.6	88.6	0.76	14.4	8.3	-	103.9	60.0	-
3LM4 80-250/5.5R	132	5.5	7.5	IE3	6.14	87.2	88.5	89.6	0.78	-	10.9	6.3	-	120.0	69.6
3LM4 80-250/5.5		5.5	7.5	IE3	6.14	87.2	88.5	89.6	0.78	-	10.9	6.3	-	120.0	69.6
3LM4 80-250/7.5	132M	7.5	10	IE3	8.27	89.8	90.9	90.4	0.78	-	15.3	8.8	-	125.5	72.4

MOTOR DATA 3(.)S4-3(.)P4

Pump type		Motor size	Motor Power		Efficiency	Input [kW]	Efficiency (% load) and power-factor				Full load current [A]			Locked rotor current [A]			
			[kW]	[HP]			η %		cos-φ	230 V	400 V	690 V	230 V	400 V	690 V		
							50%	75%	100%								
3(.)S4 32-125/0.25	3(.)P4 32-125/0.25	71	0.25	0.33	-	0.41	55.0	59.0	64.0	0.66	1.6	0.9	-	5.0	2.9	-	
3(.)S4 32-160/0.37R	3(.)P4 32-160/0.37R		0.37	0.5	-	0.56	60.0	63.0	67.0	0.67	2.1	1.2	-	6.8	3.9	-	
3(.)S4 32-160/0.37	3(.)P4 32-160/0.37		0.37	0.5	-	0.56	60.0	63.0	67.0	0.67	2.1	1.2	-	8.5	4.9	-	
3(.)S4 32-200/0.55R	3(.)P4 32-200/0.55R	80	0.55	0.75	-	0.80	67.0	69.0	70.0	0.72	2.8	1.6	-	9.9	5.7	-	
3(.)S4 32-200/0.55	3(.)P4 32-200/0.55		0.55	0.75	-	0.80	67.0	69.0	70.0	0.72	2.8	1.6	-	9.9	5.7	-	
3(.)S4 32-200/0.75	3(.)P4 32-200/0.75		0.75	1	-	IE2 0.95	79.2	80.3	80.2	0.76	3.1	1.8	-	17.1	9.9	-	
						IE3 0.92	80.7	81.5	82.5	0.74	3.1	1.8	-	17.3	10.0	-	
3(.)S4 40-125/0.37R	3(.)P4 40-125/0.37R	71	0.37	0.5	-	0.56	60.0	63.0	67.0	0.67	2.1	1.2	-	6.8	3.9	-	
3(.)S4 40-125/0.37	3(.)P4 40-125/0.37		0.37	0.5	-	0.56	60.0	63.0	67.0	0.67	2.1	1.2	-	6.8	3.9	-	
3(.)S4 40-160/0.55R	3(.)P4 40-160/0.55R		0.55	0.75	-	0.80	67.0	69.0	70.0	0.72	2.8	1.6	-	9.9	5.7	-	
3(.)S4 40-160/0.55	3(.)P4 40-160/0.55	80	0.55	0.75	-	0.80	67.0	69.0	70.0	0.72	2.8	1.6	-	9.9	5.7	-	
3(.)S4 40-200/1.1R	3(.)P4 40-200/1.1R		1.1	1.5	-	IE2 1.33	81.4	82.7	82.5	0.77	4.3	2.5	-	26.3	15.2	-	
3(.)S4 40-200/1.1	3(.)P4 40-200/1.1		1.1	1.5	-	IE3 1.30	83.3	84.3	84.1	0.75	4.3	2.5	-	30.7	17.7	-	
		90S				IE2 1.33	81.4	82.7	82.5	0.77	4.3	2.5	-	26.3	15.2	-	
							IE3 1.30	83.3	84.3	84.1	0.75	4.3	2.5	-	30.7	17.7	-
3(.)S4 40-200/1.5	3(.)P4 40-200/1.5		1.5	2	-	IE2 1.81	82.0	83.5	83.0	0.77	5.9	3.4	-	37.6	21.7	-	
		90L				IE3 1.80	84.1	85.2	85.3	0.72	6.2	3.6	-	41.0	23.7	-	
3(.)S4 50-125/0.55R	3(.)P4 50-125/0.55R		0.55	0.75	-	0.80	67.0	69.0	70.0	0.72	2.8	1.6	-	9.9	5.7	-	
3(.)S4 50-125/0.55	3(.)P4 50-125/0.55		0.55	0.75	-	0.80	67.0	69.0	70.0	0.72	2.8	1.6	-	9.9	5.7	-	
3(.)S4 50-160/1.1R	3(.)P4 50-160/1.1R	90S	1.1	1.5	-	IE2 1.33	81.4	82.7	82.5	0.77	4.3	2.5	-	26.3	15.2	-	
3(.)S4 50-160/1.1	3(.)P4 50-160/1.1		1.1	1.5	-	IE3 1.30	83.3	84.3	84.1	0.75	4.3	2.5	-	30.7	17.7	-	
							IE2 1.81	82.0	83.5	83.0	0.77	5.9	3.4	-	37.6	21.7	-
		90L				IE3 1.80	84.1	85.2	85.3	0.72	6.2	3.6	-	41.0	23.7	-	
3(.)S4 50-200/1.5R	3(.)P4 50-200/1.5R		1.5	2	-	IE2 1.81	82.0	83.5	83.0	0.77	5.9	3.4	-	37.6	21.7	-	
3(.)S4 50-200/1.5	3(.)P4 50-200/1.5		1.5	2	-	IE3 1.80	84.1	85.2	85.3	0.72	6.2	3.6	-	41.0	23.7	-	
		100L				IE2 2.61	84.0	85.3	85.1	0.74	8.8	5.1	-	53.0	30.6	-	
3(.)S4 50-200/2.2	3(.)P4 50-200/2.2		2.2	3	-	IE3 2.58	83.2	86.2	86.7	0.63	10.2	5.9	-	73.6	42.5	-	
							IE2 2.61	84.0	85.3	85.1	0.74	8.8	5.1	-	53.0	30.6	-
		80				IE3 2.58	83.2	86.2	86.7	0.63	10.2	5.9	-	73.6	42.5	-	
3(.)S4 65-125/0.55	3(.)P4 65-125/0.55		0.55	0.75	-	0.80	67.0	69.0	70.0	0.72	2.8	1.6	-	9.9	5.7	-	
3(.)S4 65-125/0.75	3(.)P4 65-125/0.75		0.75	1	-	IE2 0.95	79.2	80.3	80.2	0.76	3.1	1.8	-	17.1	9.9	-	
		90S				IE3 0.92	80.7	81.5	82.5	0.74	3.1	1.8	-	17.3	10.0	-	
3(.)S4 65-125/1.1	3(.)P4 65-125/1.1		1.1	1.5	-	IE2 1.33	81.4	82.7	82.5	0.77	4.3	2.5	-	26.3	15.2	-	
3(.)S4 65-160/1.1	3(.)P4 65-160/1.1		1.1	1.5	-	IE3 1.30	83.3	84.3	84.1	0.75	4.3	2.5	-	30.7	17.7	-	
		90L				IE2 1.81	82.0	83.5	83.0	0.77	5.9	3.4	-	37.6	21.7	-	
3(.)S4 65-160/1.5	3(.)P4 65-160/1.5		1.5	2	-	IE3 1.80	84.1	85.2	85.3	0.72	6.2	3.6	-	41.0	23.7	-	
							IE2 2.61	84.0	85.3	85.1	0.74	8.8	5.1	-	53.0	30.6	-
		100L				IE3 2.58	83.2	86.2	86.7	0.63	10.2	5.9	-	73.6	42.5	-	
3(.)S4 65-200/2.2R	3(.)P4 65-200/2.2R		2.2	3	-	IE2 2.61	84.0	85.3	85.1	0.74	8.8	5.1	-	53.0	30.6	-	
3(.)S4 65-200/2.2	3(.)P4 65-200/2.2		2.2	3	-	IE3 2.58	83.2	86.2	86.7	0.63	10.2	5.9	-	73.6	42.5	-	
		3				IE2 3.47	85.3	86.6	86.4	0.77	11.3	6.5	-	71.0	41.0	-	
3(.)S4 65-200/3	3(.)P4 65-200/3		3	4	-	IE3 3.44	85.1	87.1	87.7	0.73	11.8	6.8	-	95.4	55.1	-	
							IE2 4.59	86.0	87.3	87.1	0.78	14.7	8.5	-	89.7	51.8	-
		112M				IE3 4.54	87.2	88.3	88.6	0.80	14.2	8.2	-	120.7	69.7	-	
3LS4 65-250/4	3LP4 65-250/4		4	5.5	-	IE2 6.29	87.5	88.3	88.1	0.84	-	10.8	6.2	-	79.9	46.1	
3LS4 65-250/5.5	3LP4 65-250/5.5		5.5	7.5	-	IE3 6.17	89.8	90.2	89.6	0.84	-	10.6	6.1	-	92.2	53.2	
		132S				IE2 1.81	82.0	83.5	83.0	0.77	5.9	3.4	-	37.6	21.7	-	
3LS4 80-160/1.5	3LP4 80-160/1.5		1.5	2	-	IE3 1.80	84.1	85.2	85.3	0.72	6.2	3.6	-	41.0	23.7	-	
							IE2 2.61	84.0	85.3	85.1	0.74	8.8	5.1	-	53.0	30.6	-
		100L				IE3 2.58	83.2	86.2	86.7	0.63	10.2	5.9	-	73.6	42.5	-	
3LS4 80-160/2.2R	3LP4 80-160/2.2R		2.2	3	-	IE2 2.61	84.0	85.3	85.1	0.74	8.8	5.1	-	53.0	30.6	-	
3LS4 80-160/2.2	3LP4 80-160/2.2		2.2	3	-	IE3 2.58	83.2	86.2	86.7	0.63	10.2	5.9	-	73.6	42.5	-	
		3				IE2 3.47	85.3	86.6	86.4	0.77	11.3	6.5	-	71.0	41.0	-	
3LS4 80-200/3	3LP4 80-200/3		3	4	-	IE3 3.44	85.1	87.1	87.7	0.73	11.8	6.8	-	95.4	55.1	-	
							IE2 4.59	86.0	87.3	87.1	0.78	14.7	8.5	-	89.7	51.8	-
		112M				IE3 4.54	87.2	88.3	88.6	0.80	14.2	8.2	-	120.7	69.7	-	
3LS4 80-200/4R	3LP4 80-200/4R		4	5.5	-	IE2 4.59	86.0	87.3	87.1	0.78	14.7	8.5	-	89.7	51.8	-	
3LS4 80-200/4	3LP4 80-200/4		4	5.5	-	IE3 4.54	87.2	88.3	88.6	0.80	14.2	8.2	-	120.7	69.7	-	
		132S				IE2 6.29	87.5	88.3	88.1	0.84	-	10.8	6.2	-	79.9	46.1	
3LS4 80-250/5.5R	3LP4 80-250/5.5R		5.5	7.5	-	IE3 6.17	89.8	90.2	89.6	0.84	-	10.6	6.1	-	92.2	53.2	
3LS4 80-250/5.5	3LP4 80-250/5.5		5.5	7.5	-	IE2 6.29	87.5	88.3	88.1	0.84	-	10.8	6.2	-	79.9	46.1	
		132M				IE3 6.17	89.8	90.2	89.6	0.84	-	10.6	6.1	-	92.2	53.2	
3LS4 80-250/7.5	3LP4 80-250/7.5		7.5	10	-	IE3 8.27	89.8	90.9	90.4	0.78	-	15.3	8.8	-	125.5	72.4	

NOISE DATA 3(.)M4

Pump type	Power		LpA - dB(A) *
	[kW]	[HP]	
3(.)M4 32-125/0.25	0.25	0.33	<70
3(.)M4 32-160/0.37R	0.37	0.5	
3(.)M4 32-160/0.37	0.37	0.5	
3(.)M4 32-200/0.55R	0.55	0.75	
3(.)M4 32-200/0.55	0.55	0.75	
3(.)M4 32-200/0.75	0.75	1	
3(.)M4 40-125/0.37R	0.37	0.5	
3(.)M4 40-125/0.37	0.37	0.5	
3(.)M4 40-160/0.55R	0.55	0.75	
3(.)M4 40-160/0.55	0.55	0.75	
3(.)M4 40-200/1.1R	1.1	1.5	
3(.)M4 40-200/1.1	1.1	1.5	
3(.)M4 40-200/1.5	1.5	2	
3(.)M4 50-125/0.55R	0.55	0.75	
3(.)M4 50-125/0.55	0.55	0.75	
3(.)M4 50-160/1.1R	1.1	1.5	
3(.)M4 50-160/1.1	1.1	1.5	
3(.)M4 50-200/1.5R	1.5	2	
3(.)M4 50-200/1.5	1.5	2	
3(.)M4 50-200/2.2	2.2	3	
3(.)M4 65-125/0.55	0.55	0.75	
3(.)M4 65-125/0.75	0.75	1	
3(.)M4 65-125/1.1	1.1	1.5	
3(.)M4 65-160/1.1	1.1	1.5	
3(.)M4 65-160/1.5	1.5	2	
3(.)M4 65-160/2.2	2.2	3	
3(.)M4 65-200/2.2R	2.2	3	
3(.)M4 65-200/2.2	2.2	3	
3(.)M4 65-200/3	3	4	
3LM4 65-250/4	4	5.5	71
3LM4 65-250/5.5	5.5	7.5	71
3LM4 80-160/1.5	1.5	2	<70
3LM4 80-160/2.2R	2.2	3	
3LM4 80-160/2.2	2.2	3	
3LM4 80-200/3	3	4	
3LM4 80-200/4R	4	5.5	
3LM4 80-200/4	4	5.5	
3LM4 80-250/5.5R	5.5	7.5	71
3LM4 80-250/5.5	5.5	7.5	
3LM4 80-250/7.5	7.5	10	<70**

* Mean value of several measures at 1m distance around the pump.
Tolerance ± 2.5 dB.
Sound pressure level of motor pumps with AEG.

NOISE DATA 3(.)S4-3(.)P4

Pump type		Power		LpA - dB(A) *
3(.)S4	3(.)P4	[kW]	[HP]	
3(.)S4 32-125/0.25	3(.)P4 32-125/0.25	0.25	0.33	<70
3(.)S4 32-160/0.37R	3(.)P4 32-160/0.37R	0.37	0.5	
3(.)S4 32-160/0.37	3(.)P4 32-160/0.37	0.37	0.5	
3(.)S4 32-200/0.55R	3(.)P4 32-200/0.55R	0.55	0.75	
3(.)S4 32-200/0.55	3(.)P4 32-200/0.55	0.55	0.75	
3(.)S4 32-200/0.75	3(.)P4 32-200/0.75	0.75	1	
3(.)S4 40-125/0.37R	3(.)P4 40-125/0.37R	0.37	0.5	
3(.)S4 40-125/0.37	3(.)P4 40-125/0.37	0.37	0.5	
3(.)S4 40-160/0.55R	3(.)P4 40-160/0.55R	0.55	0.75	
3(.)S4 40-160/0.55	3(.)P4 40-160/0.55	0.55	0.75	
3(.)S4 40-200/1.1R	3(.)P4 40-200/1.1R	1.1	1.5	
3(.)S4 40-200/1.1	3(.)P4 40-200/1.1	1.1	1.5	
3(.)S4 40-200/1.5	3(.)P4 40-200/1.5	1.5	2	
3(.)S4 50-125/0.55R	3(.)P4 50-125/0.55R	0.55	0.75	
3(.)S4 50-125/0.55	3(.)P4 50-125/0.55	0.55	0.75	
3(.)S4 50-160/1.1R	3(.)P4 50-160/1.1R	1.1	1.5	
3(.)S4 50-160/1.1	3(.)P4 50-160/1.1	1.1	1.5	
3(.)S4 50-200/1.5R	3(.)P4 50-200/1.5R	1.5	2	
3(.)S4 50-200/1.5	3(.)P4 50-200/1.5	1.5	2	
3(.)S4 50-200/2.2	3(.)P4 50-200/2.2	2.2	3	
3(.)S4 65-125/0.55	3(.)P4 65-125/0.55	0.55	0.75	
3(.)S4 65-125/0.75	3(.)P4 65-125/0.75	0.75	1	
3(.)S4 65-125/1.1	3(.)P4 65-125/1.1	1.1	1.5	
3(.)S4 65-160/1.1	3(.)P4 65-160/1.1	1.1	1.5	
3(.)S4 65-160/1.5	3(.)P4 65-160/1.5	1.5	2	
3(.)S4 65-160/2.2	3(.)P4 65-160/2.2	2.2	3	
3(.)S4 65-200/2.2R	3(.)P4 65-200/2.2R	2.2	3	
3(.)S4 65-200/2.2	3(.)P4 65-200/2.2	2.2	3	
3(.)S4 65-200/3	3(.)P4 65-200/3	3	4	
3LS4 65-250/4	3LP4 65-250/4	4	5.5	
3LS4 65-250/5.5	3LP4 65-250/5.5	5.5	7.5	
3LS4 80-160/1.5	3LP4 80-160/1.5	1.5	2	
3LS4 80-160/2.2R	3LP4 80-160/2.2R	2.2	3	
3LS4 80-160/2.2	3LP4 80-160/2.2	2.2	3	
3LS4 80-200/3	3LP4 80-200/3	3	4	
3LS4 80-200/4R	3LP4 80-200/4R	4	5.5	
3LS4 80-200/4	3LP4 80-200/4	4	5.5	
3LS4 80-250/5.5R	3LP4 80-250/5.5R	5.5	7.5	
3LS4 80-250/5.5	3LP4 80-250/5.5	5.5	7.5	
3LS4 80-250/7.5	3LP4 80-250/7.5	7.5	10	

* Mean value of several measures at 1m distance around the pump.
Tolerance ± 2.5 dB.
Sound pressure level of motor pumps with AEG