



EBARA

EBARA PRODUCT GENERAL CATALOGUE

50Hz



Looking ahead, going beyond expectations









Ahead > Beyond

NON-SUBMERSIBLE PUMPS

Stainless Steel pumps

Model	Shape	Driving Method	Liquid	Max. Working Pressure	Construction			Material			Page
					Impeller	Sealing	Bearing	Casing	Impeller	Shaft	
CDX		Direct	Pure Water	0.8 MPa	Enclosed	M.Seal	Ball	AISI 304	AISI 304	AISI 303	4
2CDX		Direct	Pure Water	0.8 MPa	Enclosed	M.Seal	Ball	AISI 304	AISI 304	AISI 303	4
3M		Direct	Pure Water	1 MPa	Enclosed	M.Seal	Ball	AISI 304	AISI 304	AISI 304	5
EVMS		Direct	Pure Water	2.5 MPa	Enclosed	M.Seal	Ball	AISI 304	AISI 304	AISI 304	5
JESX		Direct	Pure Water	0.6 MPa	Enclosed	M.Seal	Ball	AISI 304	PPO. mod	AISI 303	6
DWO		Direct	Pure Water	0.8 MPa	Semi-open	M.Seal	Ball	AISI 304	AISI 304	AISI 304	6
LPS		Direct	Pure Water	0.4 MPa	Enclosed	M.Seal	Ball	AISI 304	AISI 304	AISI 303	7
MATRIX		Direct	Pure Water	1 MPa	Enclosed	M.Seal	Ball	AISI 304	AISI 304	AISI 304	7
FSS		Motor Direct	Pure Water	1 MPa	Enclosed	Packing	Ball	SCS 14	SCS 14	AISI 316	9
GSO		Motor Direct	Industrial Water	1.6 MPa	Reversed Semi-open	M.Seal	Ball	SCS 13	SCS 13	SUS 304	10

Cast Iron pumps

Model	Shape	Driving Method	Liquid	Max. Working Pressure	Construction			Material			Page
					Impeller	Sealing	Bearing	Casing	Impeller	Shaft	
FS		Motor Direct	Pure Water	1 MPa	Enclosed	M.Seal	Ball	Cast Iron	Bronze	AISI 403	8
CS/CN		Motor Direct	Pure Water	1.6 MPa	Enclosed	M.Seal	Ball	Cast Iron	Bronze	AISI 316	8
GS		Motor Direct	Pure Water	1.6 MPa	Enclosed	M.Seal	Ball	Cast Iron	Bronze	Duplex SUS	9
SQPB		Motor Direct	Pure Water	0.25 MPa	Semi-open	Packing	Ball	Cast Iron	Cast Iron	Carbon Steel	10
3E		Direct	Pure Water	1 ~ 1.6 MPa	Enclosed	M.Seal	Ball	Cast Iron	AISI 304, AISI 316L	AISI 304, AISI 316L	11
3D		Direct	Pure Water	1 MPa	Enclosed	M.Seal	Ball	Cast Iron	AISI 304	AISI 304	12
CDA		Direct	Pure Water	1 MPa	Twin closed	M.Seal	Ball	Cast Iron	PPO. mod	AISI 303, AISI 304	12
CM		Direct	Pure Water	0.8 MPa	Enclosed	M.Seal	Ball	Cast Iron	PPO. mod	AISI 416, AISI 420	13

Borehole Pumps

Model	Shape	Driving Method	Liquid	Max. Immersion	Construction			Material			Page
					Impeller	Sealing	Bearing	Casing	Impeller	Shaft	
SB3		Motor Direct	Clear Water	60 m	Close	-	Sleeve	AISI 304	PPO Fiberglass	AISI 430F	14
WINNER4N		Motor Direct	Clear Water	350 m	-	-	Sleeve	AISI 304	Lxef	AISI 304	14
IDROGO		Motor Direct	Clear Water	20 m	-	M.Seal	Ball	AISI 304	PPE + PS	AISI 431	14
SF6		Motor Direct	Clear Water	350 m	Close	-	Sleeve	Cast Iron AISI 304	PPO Fiberglass	AISI 420	14

SUBMERSIBLE PUMPS

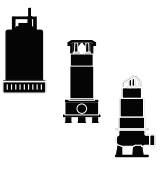
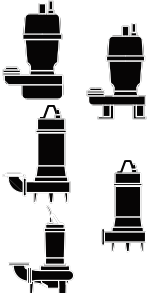
Model	Shape	Driving Method	Liquid	Maximum Submergence	Construction			Material			Page
					Impeller	Sealing	Bearing	Casing	Impeller	Shaft	
OPTIMA		Direct	Waste Water	5 m	Semi-open(strainer)	M.Seal	Ball	AISI 304	PPE+PS reinforced with fiberglass	AISI 303	15
BEST		Direct	Dirty Water	10 m	Semi-open(strainer)	D.M.Seal	Ball	AISI 304	AISI 304	AISI 303	15
RIGHT		Direct	Dirty Water	10 m	Semi-open(vortex)	D.M.Seal	Ball	AISI 304	AISI 304	AISI 303	16
DW		Direct	Sewage Water	10 m	Single channel, Vortex	D.M.Seal	Ball	AISI 304	AISI 304	AISI 303	16
DS		Direct	Dirty Water	8 m	Semi-open(strainer)	Double M.Seal	Ball	Cast Iron	Cast Iron	AISI 403	17
DVS		Direct	Dirty Water	8 m	Semi-vortex	Double M.Seal	Ball	Cast Iron	Cast Iron	AISI 403	17
DL		Direct	Sewage Water	8 m	Non - clog	Double M.Seal	Ball	Cast Iron	Cast Iron	AISI 403	18
DF		Direct	Sewage Water	8 m	Non-clog semi-open	Double M.Seal	Ball	Cast Iron	Cast Iron	AISI 403	18
DML		Direct	Sewage Water	8 m	Non-clog, single chanel	Double M.Seal	Ball	Cast Iron	Cast Iron	AISI 403	19

Series	Shape	Driving Method	Liquid	Max. Working Pressure	Construction			Material			Page
					Impeller	Sealing	Bearing	Casing	Impeller	Shaft	
UD3		Direct	Pure Water	1 MPa	Enclosed	M.Seal	Ball	AISI 304	AISI 304	AISI 304	20
UN3		Direct	Pure Water		Enclosed	M.Seal	Ball	AISI 304	AISI 304	AISI 304	22
DBU		Direct	Pure Water		Enclosed	M.Seal	Ball	AISI 304	AISI 304	AISI 304	25

Fire Fighting Pumps

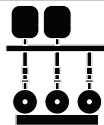
Series	Shape	Driving Method	Liquid	Max. Working Pressure	Construction			Material			Page
					Impeller	Sealing	Bearing	Casing	Impeller	Shaft	
FFS-FFB		Motor Engine	Pure Water	12 bar.	-	-	-	-	-	-	27
FSPA		Motor Engine	Pure Water	250 psi	Enclosed	Packing	Ball	FCD450	CAC406	SUS316	28
CNPA		Motor Engine	Pure Water		Enclosed	Packing	Ball	FC250	CAC406	SUS316	28

Applications

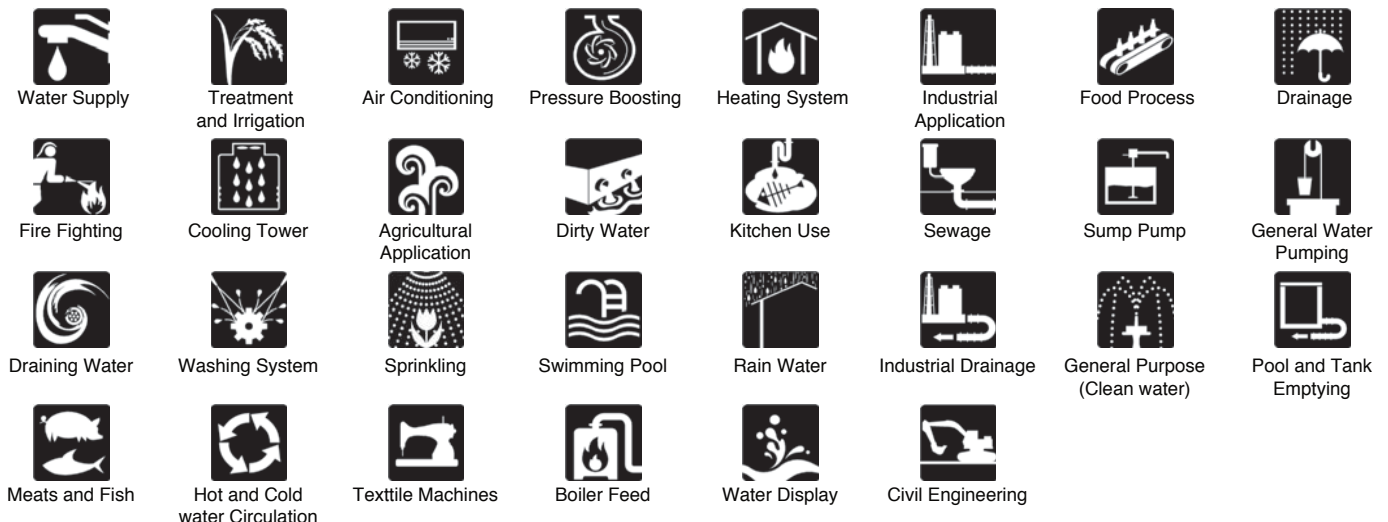

NON-SUBMERSIBLE PUMPS

MODEL CDX CENTRIFUGAL PUMPS

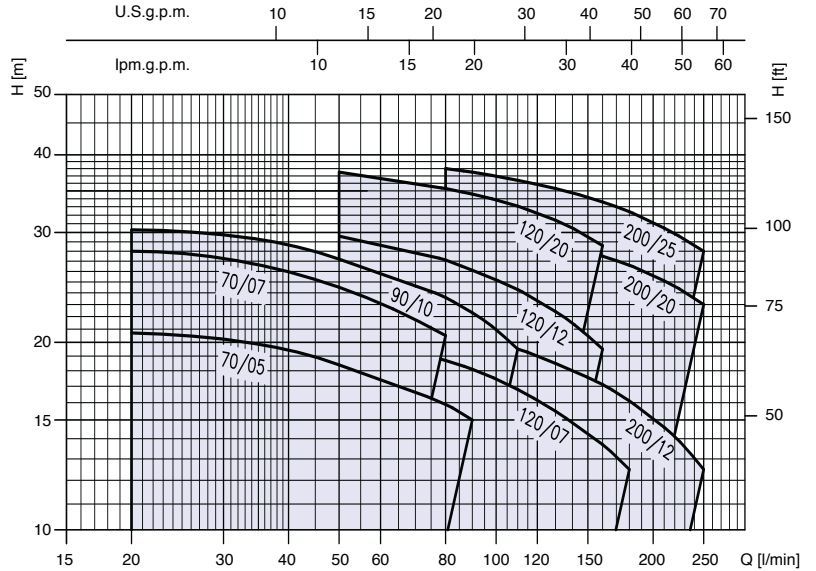

■ Features

1. Hydraulic robust construction.
2. High performances and efficiency.
3. Integrated volute obtained from hydro-forming process.
4. Low noise.
5. Compact dimensions.

MODEL 2CDX TWIN IMPELLER CENTRIFUGAL PUMPS

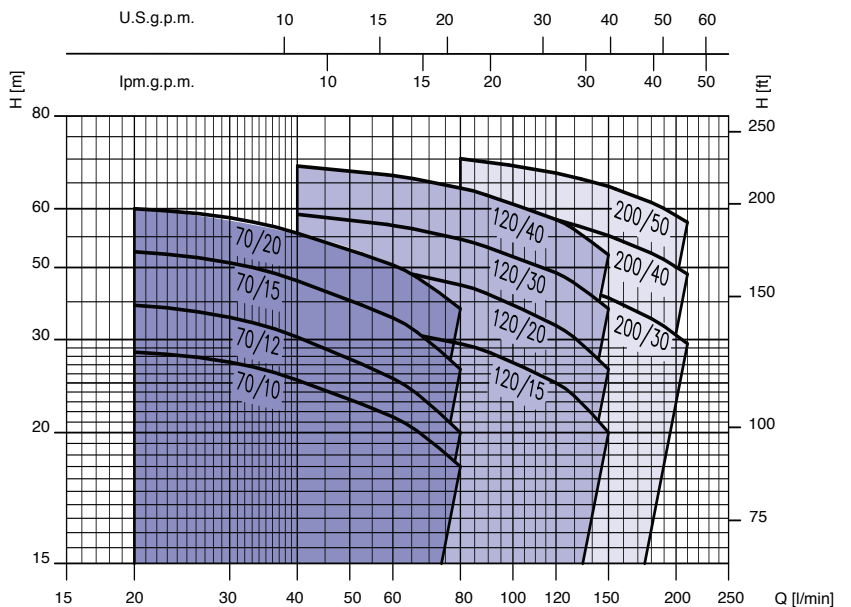

■ Features

1. Hydraulic robust construction.
2. High performances and efficiency.
3. Integrated volute obtained from hydro-forming process.
4. Silent.
5. Compact dimensions.

MODEL 3M Series CENTRIFUGAL PUMPS

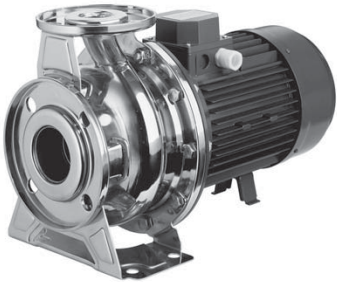

■ **Features**

1. Robust hydraulic construction.
2. Versatile, it is possible to handle a wide range of fluid (304 or 316 version).
3. Volute casing for high efficiency.
4. With AISI 304 pump pump foot at standard.
5. All pump casing fixed screw in AISI 304.
6. Compact design.
7. Wide range of performances with 2-4 poles motor .
8. Standard dimension as ISO EN 733.
9. Back pull out design – easy to dismantle, pump casing remain to the pipe.
10. Standard mechanical seal DIN 24960.
11. Other customize solutions to meet all your needs.

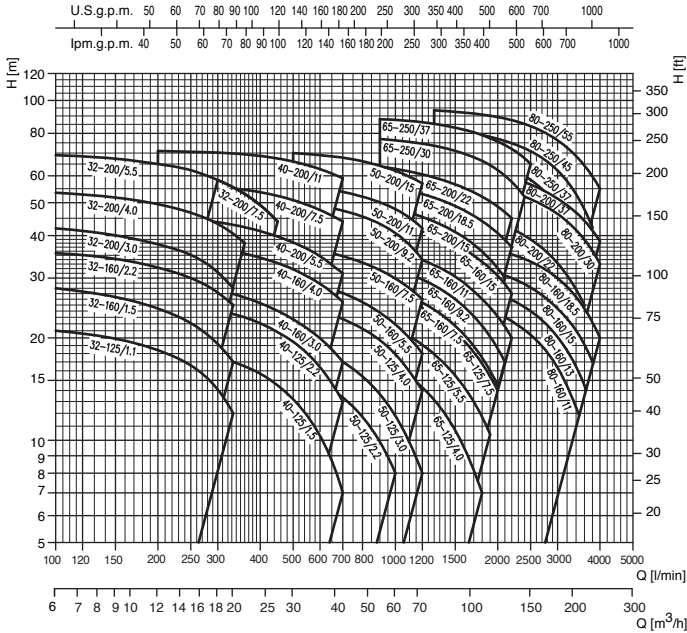

MODEL EVMS VERTICAL MULTISTAGE CENTRIFUGAL PUMPS



eDYNAMiQ
Eco, Dynamic and Integrated Quality

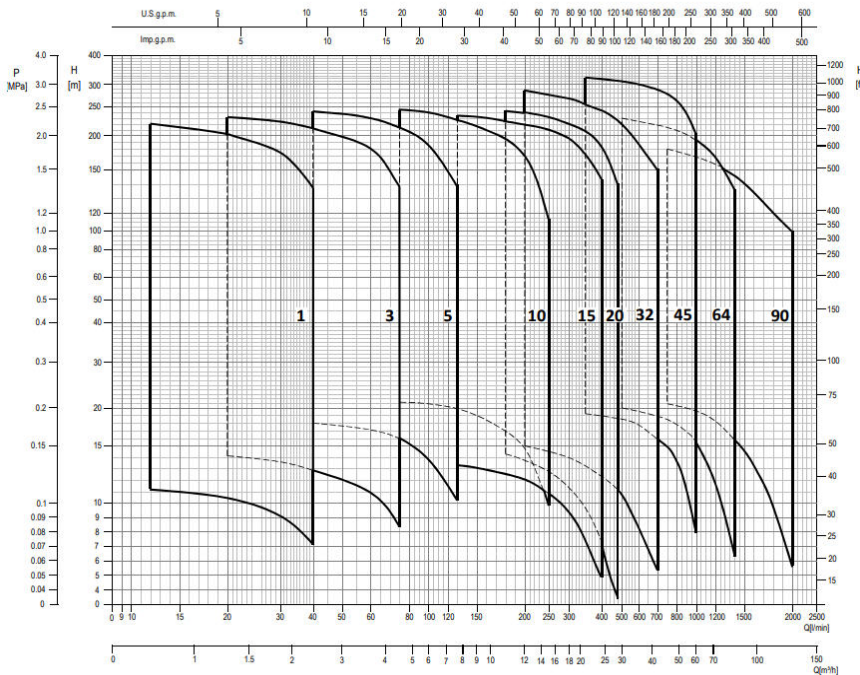

■ **Features**

1. Maximum operating range at 16 bar ~ 35 bar /-30 to +140°c depend on model
2. Available for various operating range, EVMS 1 - 90 m³/ h flow sizes
3. Material version in Cast iron, AISI 304 and AISI 316L
4. Pipe connections : Round flange/Loose flange/Oval flange/Victaulic connection/Clamp connection for EVMS 1 - 20 and Loose flange for EVMS 32 - 90
5. Motor IE3 can be provided above 0.75 kw

MODEL JEX / JESX CENTRIFUGAL PUMPS



Materials

1. Pump body and seal housing disc in AISI 304.
2. AISI 303 shaft (part in contact with the liquid).
3. Impeller in AISI 304 for JEX, in PRO reinforced with fiberglass for JESX.
4. Mechanical seal in Carbon/Ceramic/NBR.
5. Support and motor casing in aluminium.

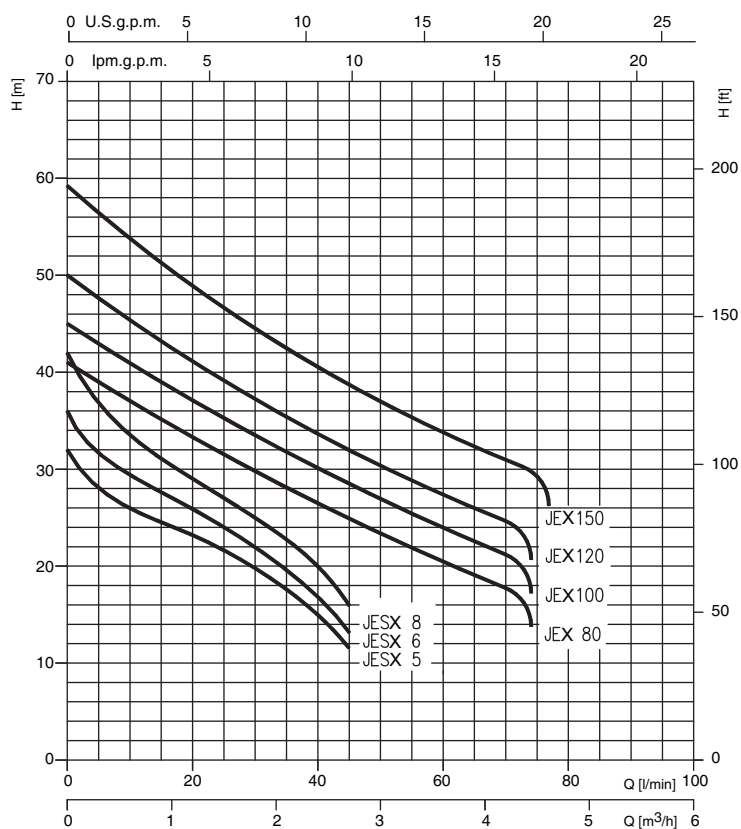

MODEL DWO CENTRIFUGAL PUMPS

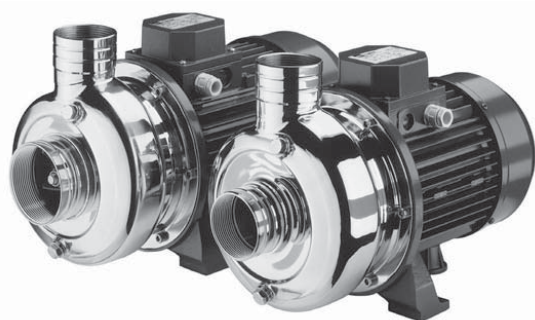

Features

1. Hydraulic robust construction.
2. High performances and efficiency.
3. The Hydro-forming process to obtain the integrated volute is patented.
4. Low noise.
5. Compact dimensions.
6. Passage of solids: maximum diameter of 19 mm.

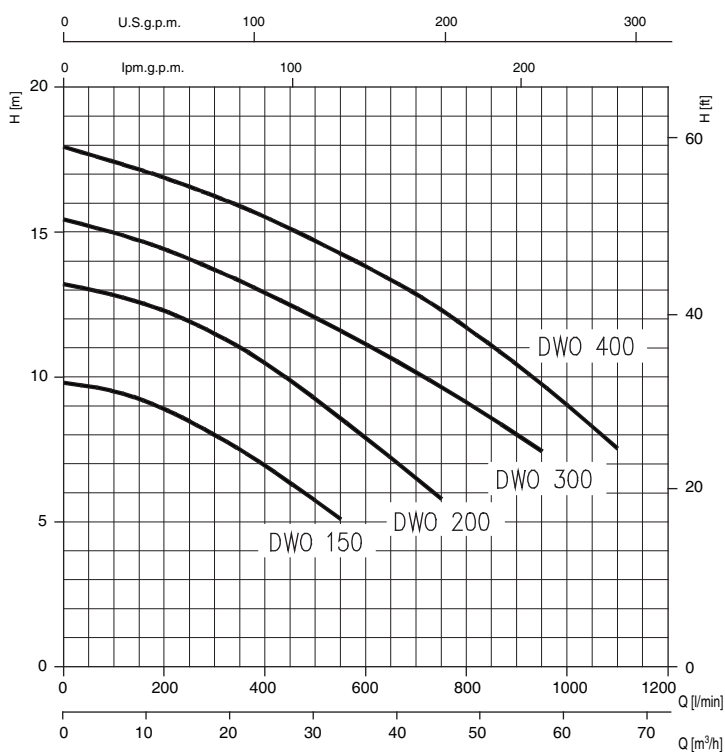

MODEL LPS IN-LINE CENTRIFUGAL PUMPS



■ Features

1. Hydraulic robust construction.
2. Low noise.
3. Compact dimensions.
4. Totally in AISI 304.

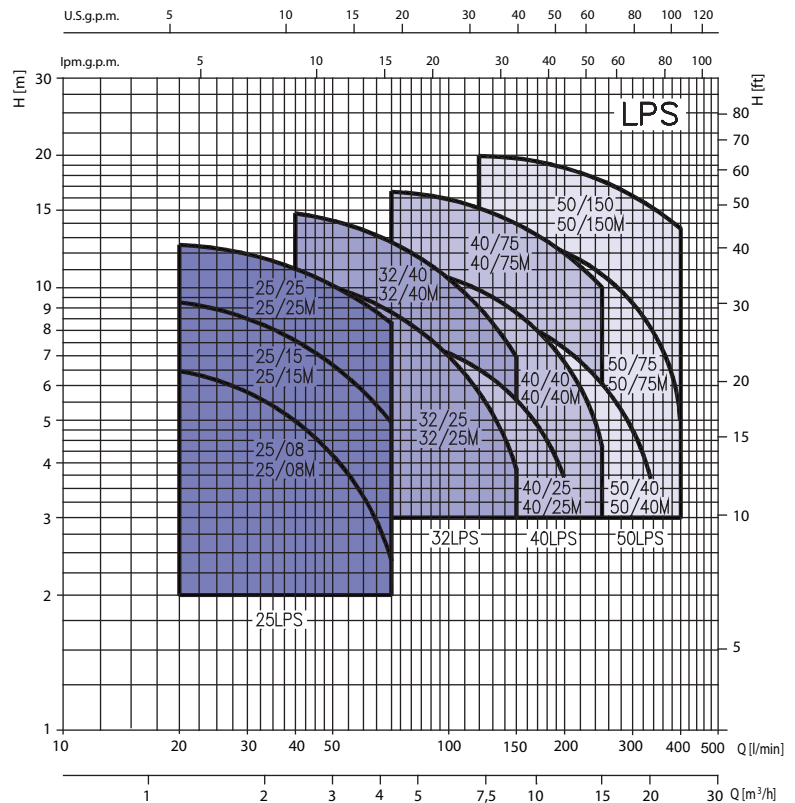

MODEL MATRIX HORIZONTAL MULTISTAGE CENTRIFUGAL PUMPS



■ Features

1. All metal components in contact with the liquid in the pump are made of stainless steel.
2. Tungsten carbide and ceramic are used for sleeve type bearing in contact with the liquid.
3. Floating liner ring in AISI 304 and PTFE.

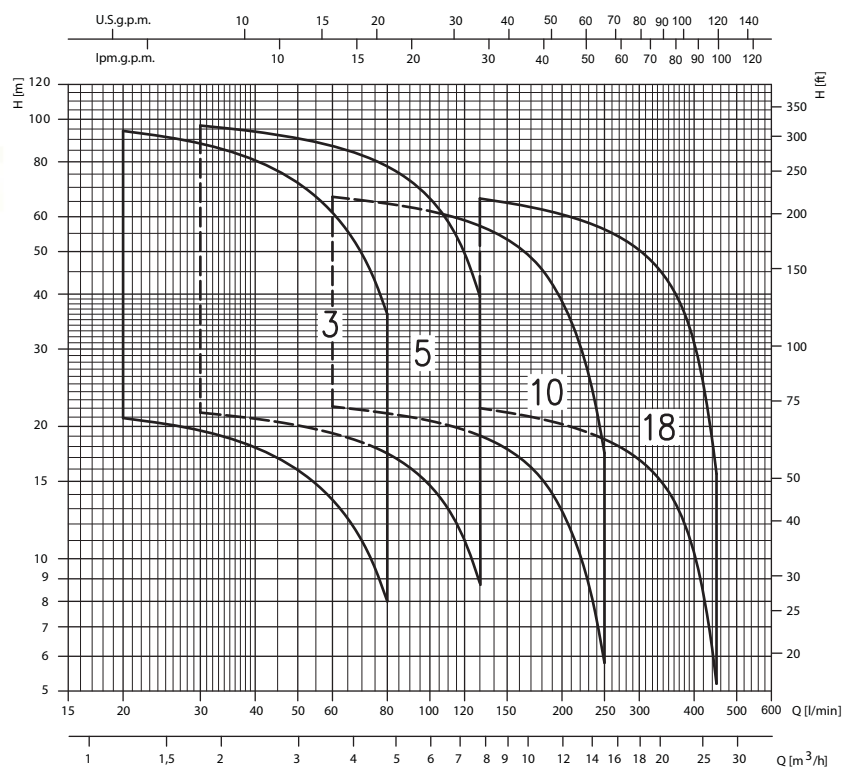

NON-SUBMERSIBLE PUMPS

MODEL FS

CAST IRON END SUCTION
VOLUTE PUMPS

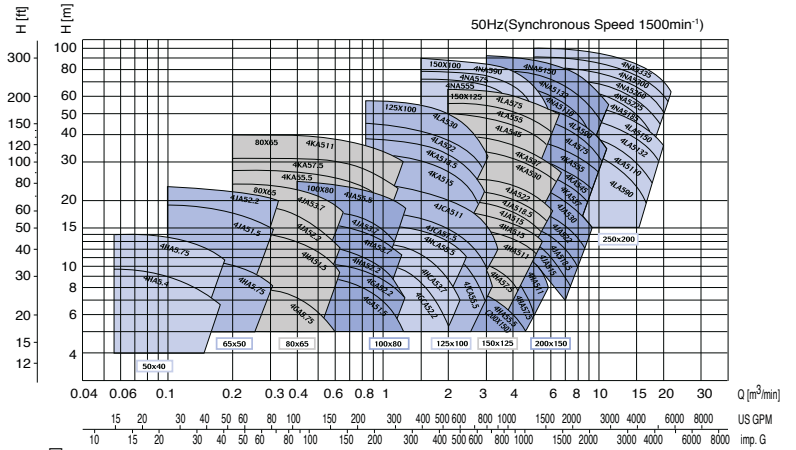
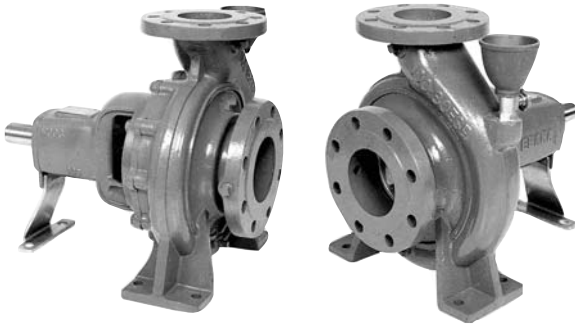

Features

1. Easy maintenance BPO (Back Pull Out) feature allows all rotating element to be removed without disconnecting the suction and discharge pipework.
2. Top centerline discharge, foot support under casing for maximum resistance to misalignment and distortion from pipe loads.
3. Higher operating efficiency over a wider range of capacities, lowers operational cost.
4. Flange connection with JIS standard.

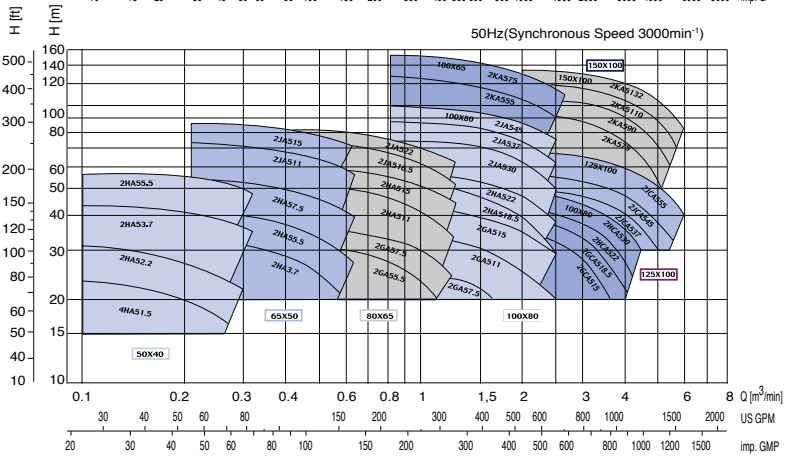

MODEL CS/CN

HORIZONTAL SPLIT
CASING PUMPS

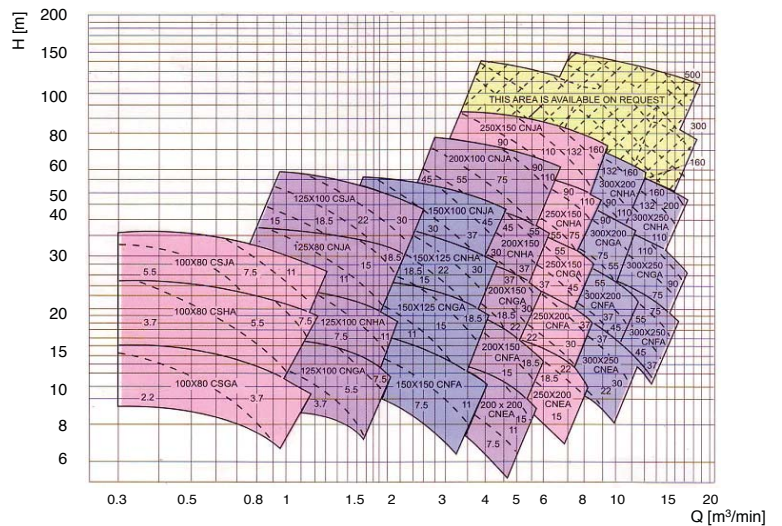
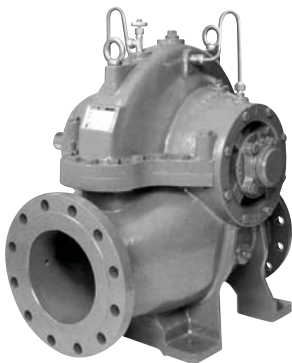

Features

1. Very Compact design for ease of installation and permits minimum maintenance.
2. Axially split casing allows the easy removal of the top casing for inspection and service.
3. A wider range of performance with head up to 150m.
4. High speed drives and vertical mount available.
5. Anti-corrosion materials used on the rotating parts.
6. High quality sealed and cartridge type bearing units provide high durability.
7. High allowable working pressure can ensure stable running.
8. Mechanical seal for easy maintenance.
9. Flange connection with JIS standard.

MODEL FSS STAINLESS STEEL L END SUCTION VOLUTE PUMPS

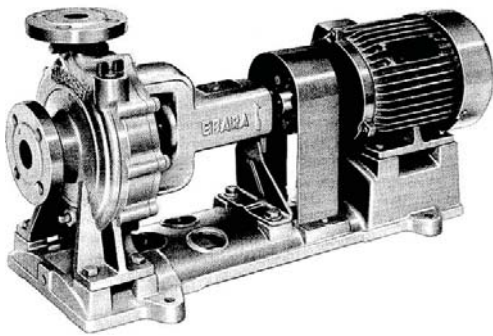

Selection Chart - 2P

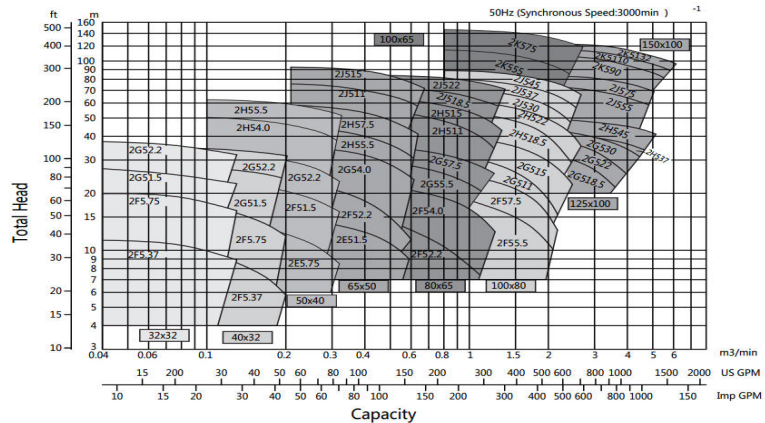

Features

1. Pump portion contacting liquid is made of high grade stainless steel.
2. Easy maintenance BPO (Back Pull Out) feature allows all rotating element to be removed without disconnecting the suction and discharge pipework.
3. Top centerline discharge, foot support under casing for maximum resistance to misalignment and distortion from pipe loads.
4. Higher operating efficiency over a wider range of capacities, lowers operational cost.
5. Flange connection with JIS standard.

Selection Chart - 4P

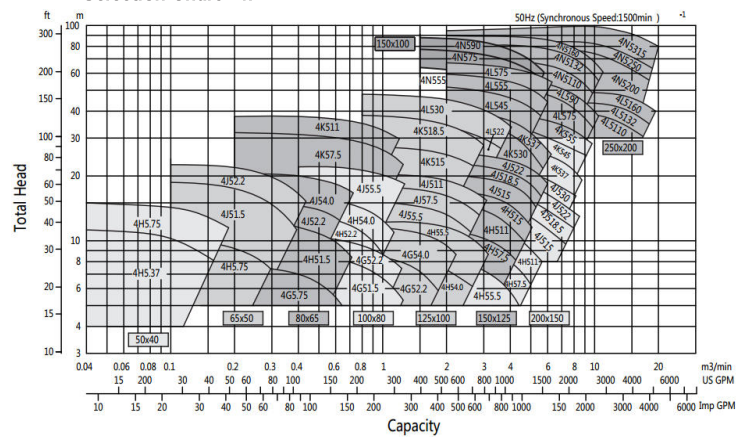

MODEL GS CAST IRON END SUCTION VOLUTE PUMPS

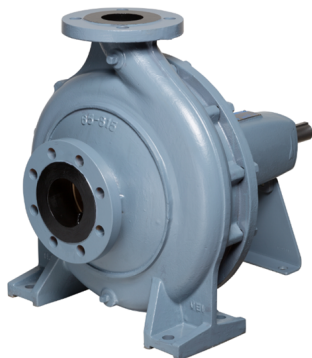

eDYNAMiQ
Eco, Dynamic and Integrated Quality

Model GS 2P/50Hz

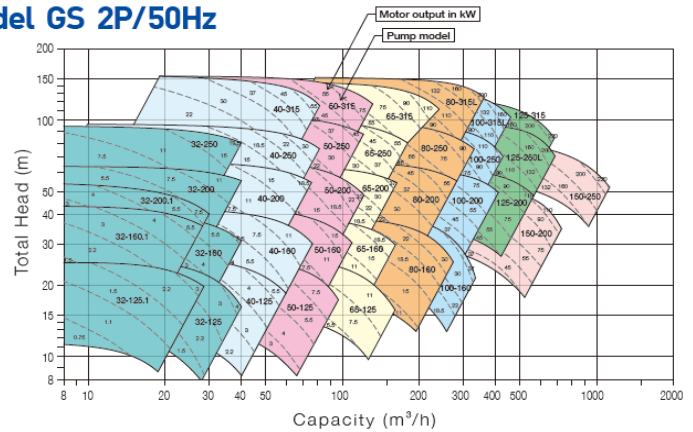

Features

1. Easy maintenance BPO (Back Pull Out) feature allows all rotating element to be removed without disconnecting the suction and discharge pipework.
2. Top centerline discharge, foot support under casing for maximum resistance to misalignment and distortion from pipe loads.
3. Higher operating efficiency over a wider range of capacities, lowers operational cost.
4. Flange connection with DIN standard.

Model GS 4P/50Hz

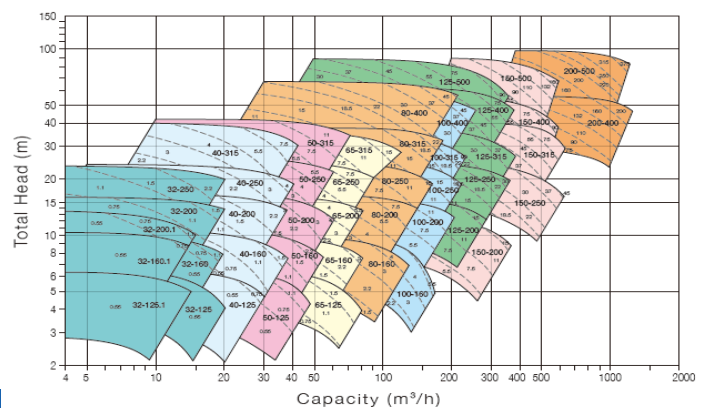

MODEL GSO HORIZONTAL END SUCTION VOLUTE PROCESS PUMPS (ISO 2858/5199)

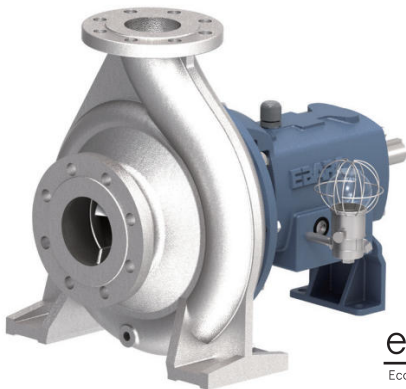

eDYNAMiQ
Eco, Dynamic and Integrated Quality

50Hz – 2950min⁻¹

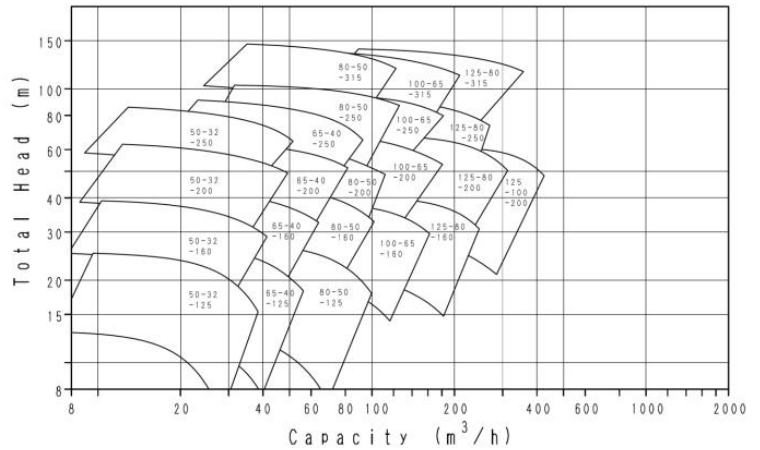

50Hz – 1450min⁻¹

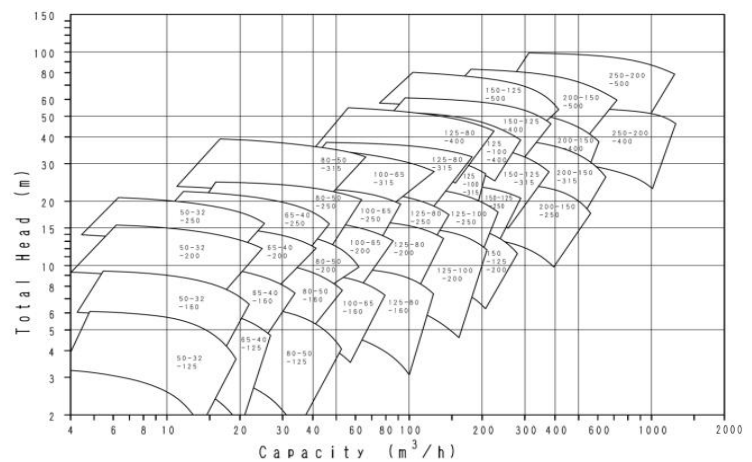

■ Features

1. Comply with international standards
Outline dimension : ISO 2858 / Pump design : ISO 5199.
2. Easy maintenance BPO (Back Pull Out) feature allows all rotating element to be removed without disconnecting the suction and discharge pipework.
3. Impeller design with reversed semi-open and suitable for both clean liquid and light slurry liquid.
4. Minimized maintenance cost and stock parts by high interchangeability of parts.
5. Less axial thrust load and low seal box pressure by unique shape impeller. Heavy duty design to reduce vibration and shaft deflection.
6. Flange connection available with DIN and JIS standard.

MODEL SQPB SELF PRIMING PUMPS

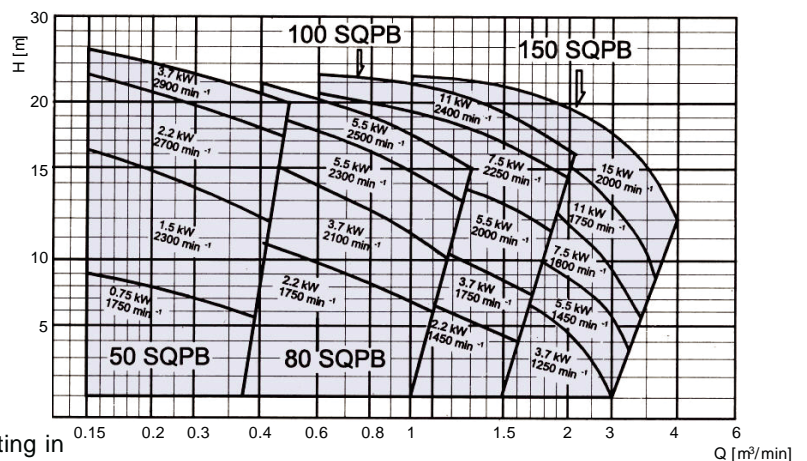

■ Features

1. Priming requirements are automatically provided resulting in simplified operations.
2. Maintenance is simplified by use of gland packing.

MODEL 3E Series IN-LINE CENTRIFUGAL ELECTRIC PUMPS



■ Features

1. Pump casing in cast iron and impeller in AISI304 for 32, 40, 50, 65 series, in AISI316L for 80, 100 series
2. Flow rate up to 216 m³/hr for model 3E and up to 192 m³/hr for model 3E-K
3. Total head up to 70 m and liquid handled temperature -10 ~ +120 oC
4. Complete with integrated E-SPD+ frequency converter for model 3E-K and available up to 11 kW
5. Robust design and Easy maintenance

3E/3ES (50 Hz - 2 poles)

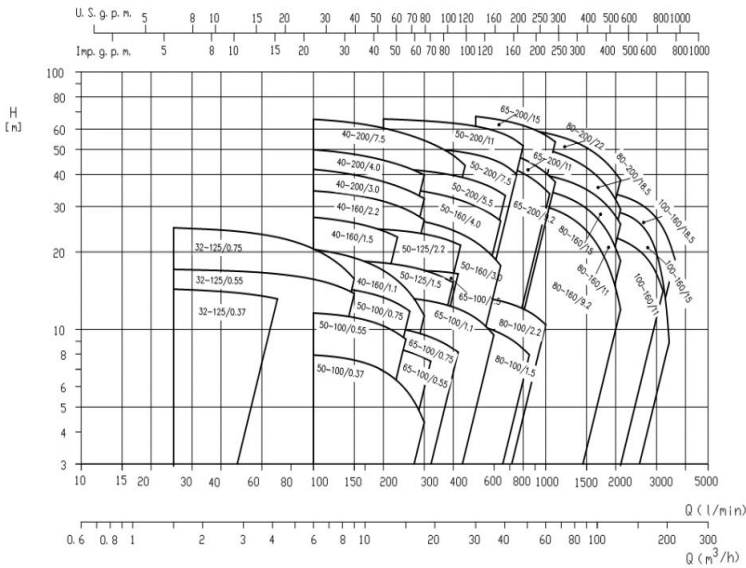

3E-K (50 Hz - 2 poles)

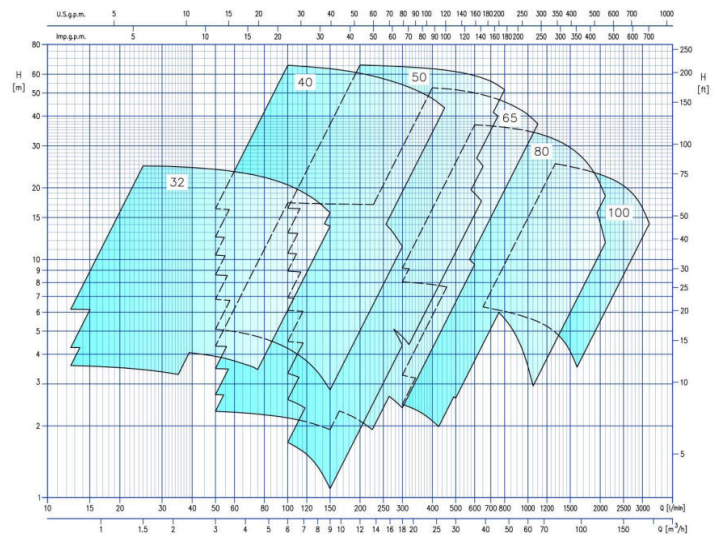

3E/3ES (50 Hz - 4 poles)

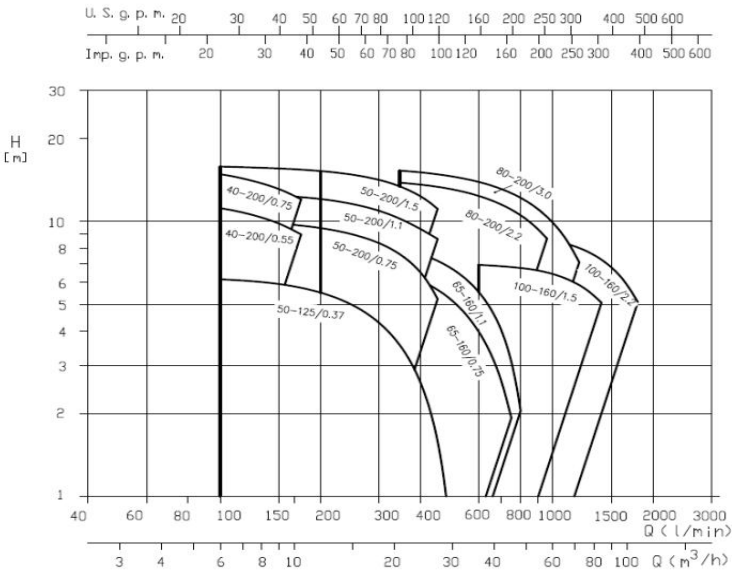

3E-K (50 Hz - 4 poles)

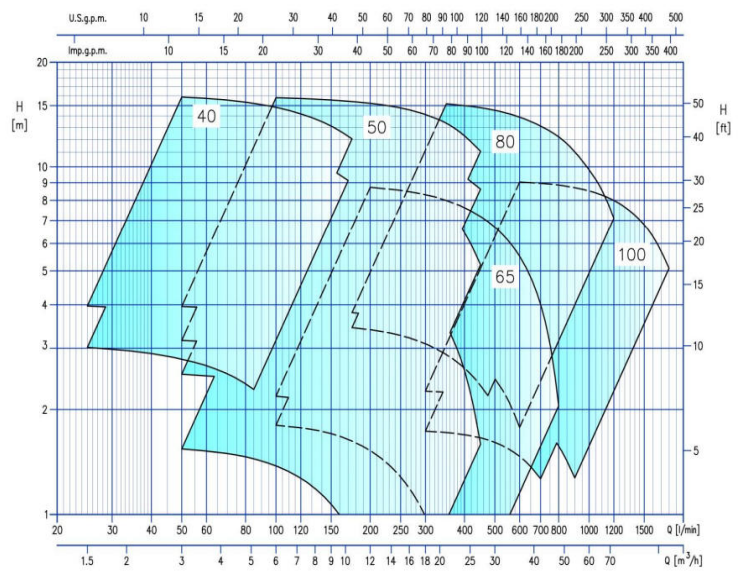

MODEL 3D CENTRIFUGAL PUMPS



Materials

1. Cast iron pump body EN-GJL-250-EN 1561
2. Stamped AISI 304 stainless steel impeller for sizes 32, 40 and 50
Maximum pressure. : 10 bar
Microcast steel impeller for size 65
3. AISI 304 seal holding disc
4. AISI 304 shaft
5. Standard mechanical seal Ceramic/Carbon/NBR

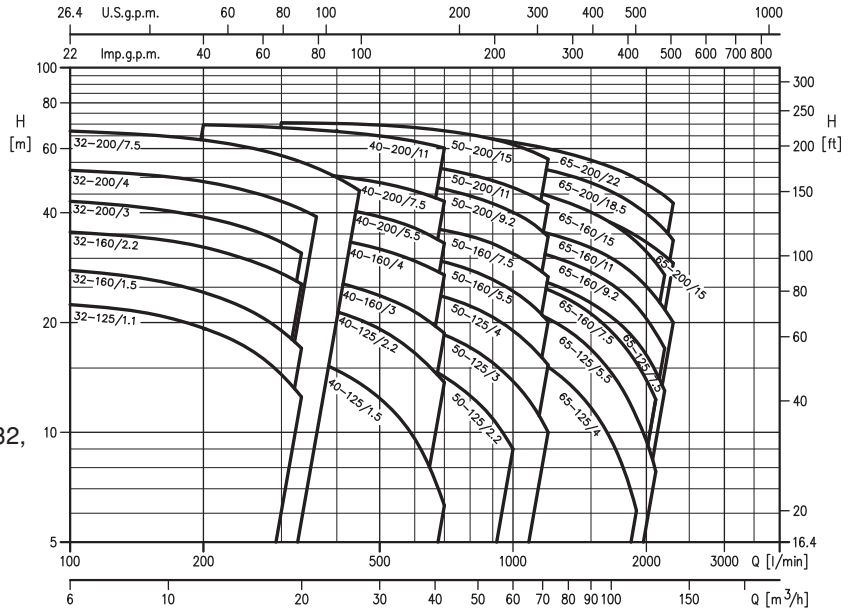

MODEL CDA TWIN IMPELLER CENTRIFUGAL ELECTRIC PUMPS

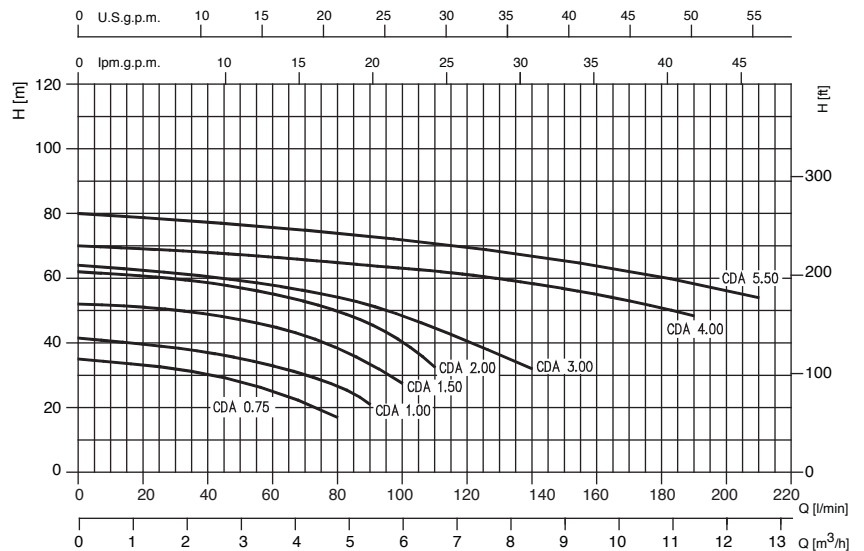

Materials

1. Cast iron pump body.
2. Mechanical seal in Carbon/Ceramic/NBR.
3. Impeller : PPE+PS glass fibre reinforced (CDA 0.75-1.00) Brass (CDA 1.50 - 5.50)
4. Shaft in AISI 303 for CDA 1.50 - 2.00 - 3.00, in AISI 304 for CDA 4.00 - 5.50, in AISI 420 for CDA 0.75 - 1.00.
5. Support in aluminium for CDA 0.75 - 1.00, in cast iron for the rest of the range.
6. Seal housing disc in AISI 304 for CDA 0.75 - 1.00, in cast iron for the rest of the range.

MODEL CMA-B-C-D CENTRIFUGAL PUMPS

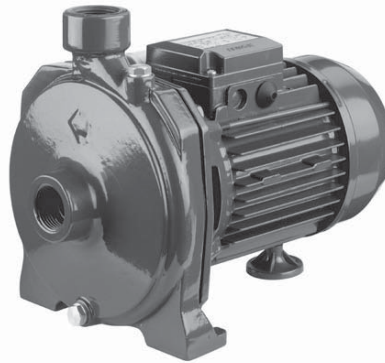

Materials

1. Cast iron pump body.
2. Mechanical seal in Carbon/Ceramic/NBR.
3. Impeller:
 - In PRO reinforced with fiberglass for CMA 0.50 - 0.75 - 1.00.
 - In brass for CMA 1.50 - 2.00 - 3.00, CMB 2.00 - 3.00 - 4.00 - 5.50, CMR 0.75 - 1.00.
 - In cast iron for CMB 0.75 - 1.00 - 1.50, CMC, CMD.
4. Shaft:
 - In AISI 303 for CMA 1.50 - 2.00 - 3.00, CMB 1.50 - 2.00 - 3.00, CMD 1.50 - 2.00 - 3.00.
 - In AISI 304 for CMB 4.00 - 5.50, CMD 4.00.
 - In AISI 416 for CMA 0.50, CMR 0.75 - 1.00.
 - In AISI 420 for CMA 0.75 - 1.00, CMB 0.75 - 1.00, CMC 0.75 - 1.00.

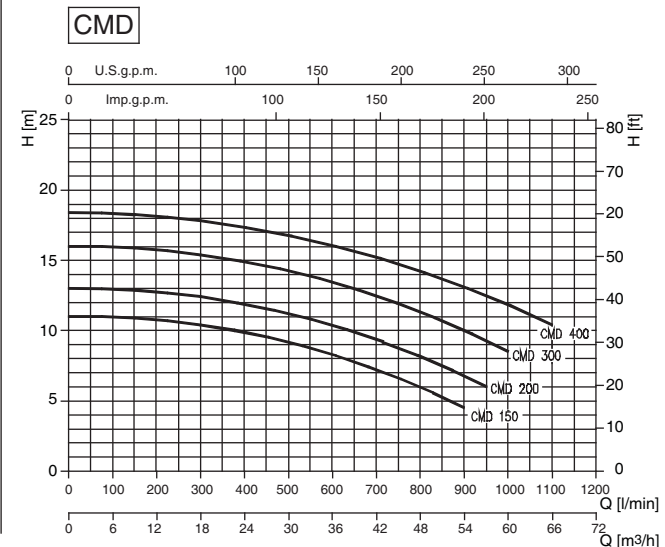
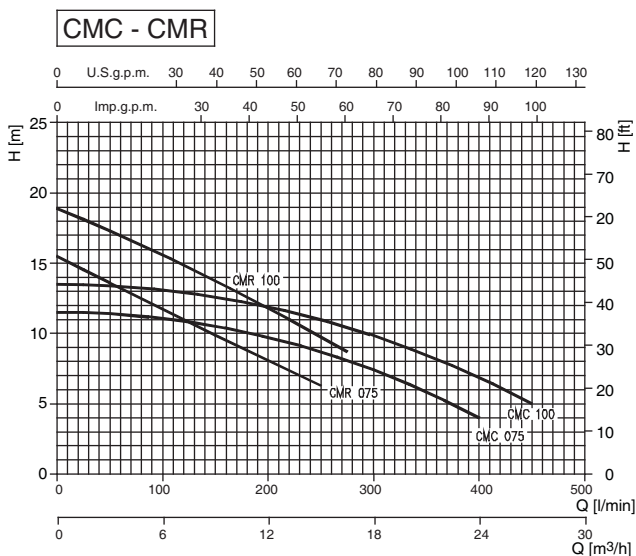
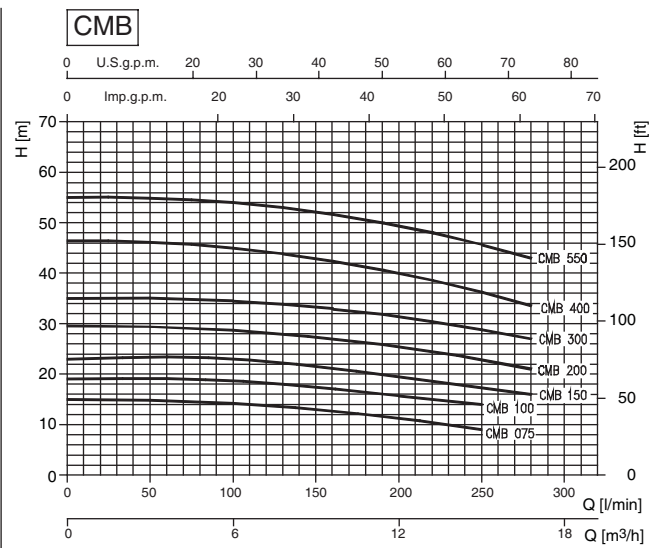
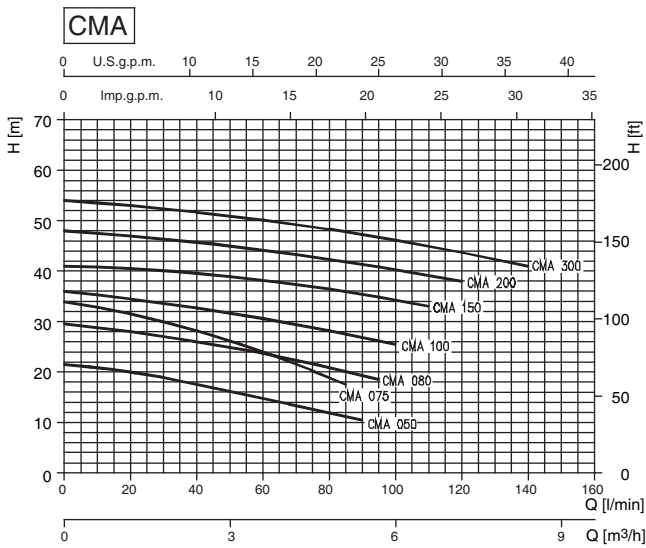

BOREHOLE PUMPS

MODEL



Features

1. Moving clear water in wells
2. Pressure boosting of clean water for agricultural, domestic or industrial use.
3. Irrigation and moving water in general.
4. Vertical or horizontal installation

Note:

1. For more information, please contact sale of EBARA (Thailand).



SB3

WINNER 4N

IDROGO

SF6

SB3 (3" Borehole Pump)

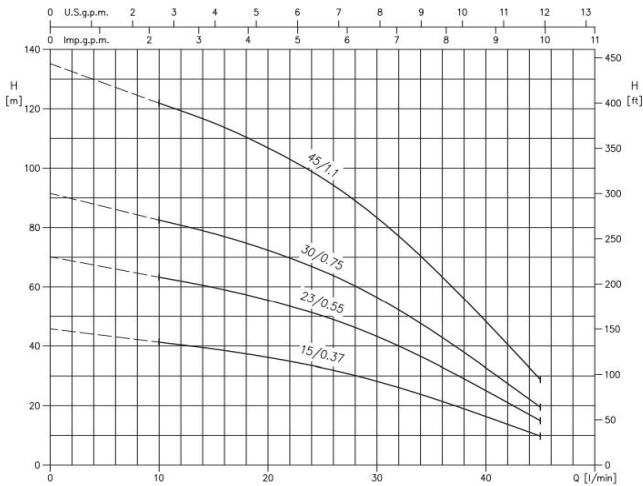

IDROGO (5" Borehole Pump)

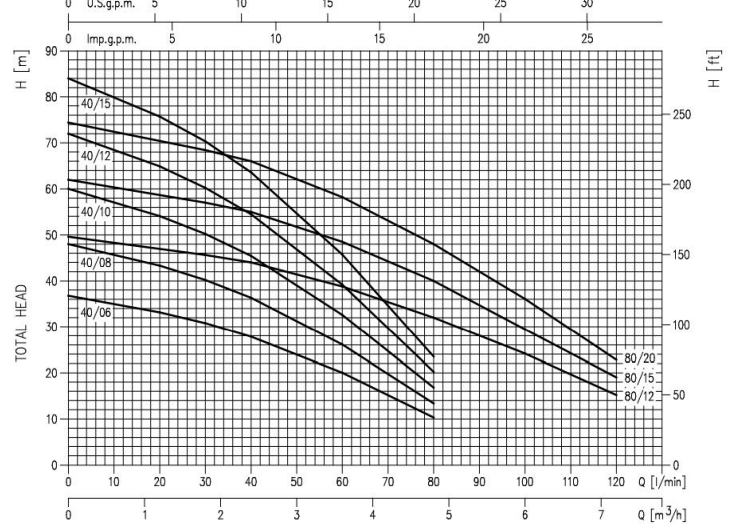

WINNER 4N (4" Borehole Pump)

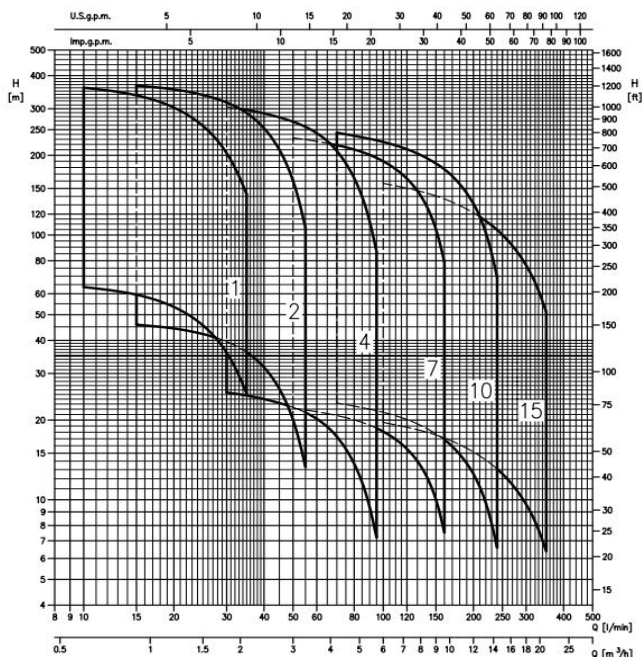

SF6 (6" Borehole Pump)

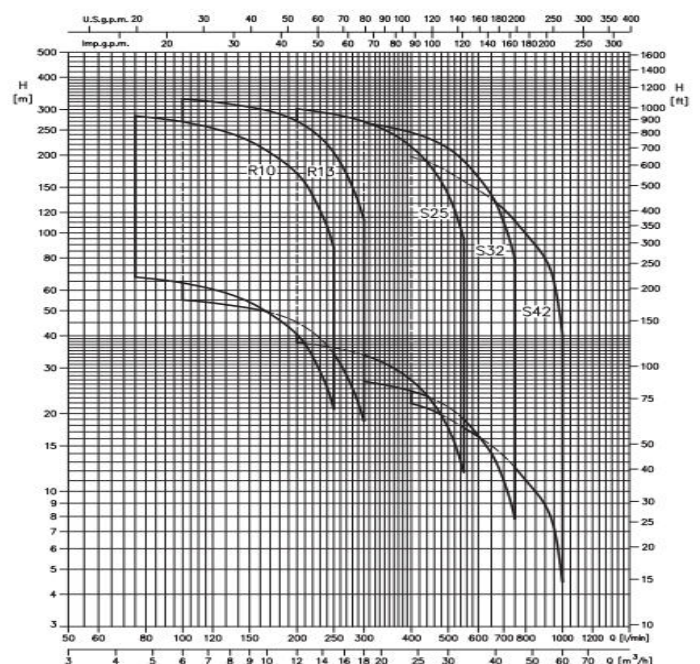

MODEL OPTIMA SUBMERSIBLE ELECTRIC PUMPS



PERFORMANCE CURVES

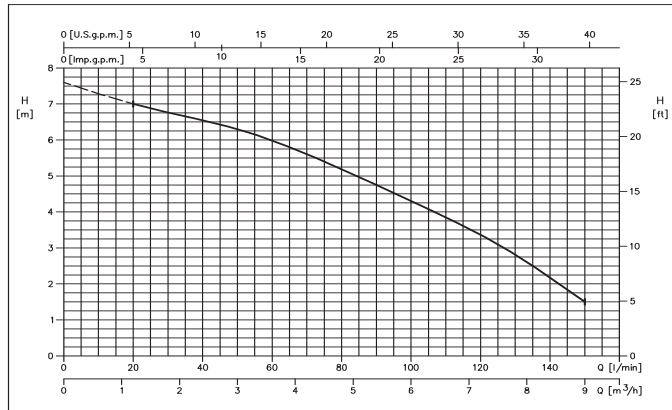

■ Features

1. Draining wells, garages, cellars or places subject to flooding.
2. Irrigation of gardens and vegetable patches.
3. Movement of seepage water or draining of unfoul waste water

■ Special Versions

1. MS version with small MS (Magnetic Switch) vertical magnetic float for clean waters.
2. MA version with float.

■ Materials

1. Pump body, suction grill, seal housing disc and motor pump body in AISI 304.
2. Impeller in PPE+PS reinforced with fibreglass.
3. Shaft in AISI 303
4. Standard mechanical seal (Carbon/Ceramic/NBR)

MODEL BEST SUBMERSIBLE SUMP PUMPS



BEST ONE



BEST 2 ~ 5

■ Features

1. Major parts are stainless steel.
2. Mechanical seal in oil chamber.
3. Light weight and compact design.
4. In build motor protection for single phase.
5. All single phase models are available as automatic operation with float switch.

■ Materials

1. Pump casing, impeller, strainer, cover, casing cover and motor casing in AISI 304
2. Shaft in AISI 303.
3. BEST ONE: Mechanical seal (pump side)+Lip seal (motor side)
—Mechanical seal : Carbon/Ceramic/NBR and Lip seal : NBR
BEST 2-5: Double mechanical seal with oil chamber:
—Motor side in Carbon/Ceramic/NBR and Pump side in SiC/SiC/NBR.

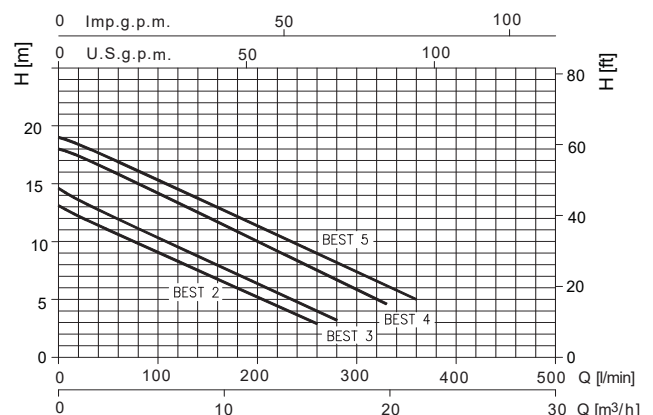
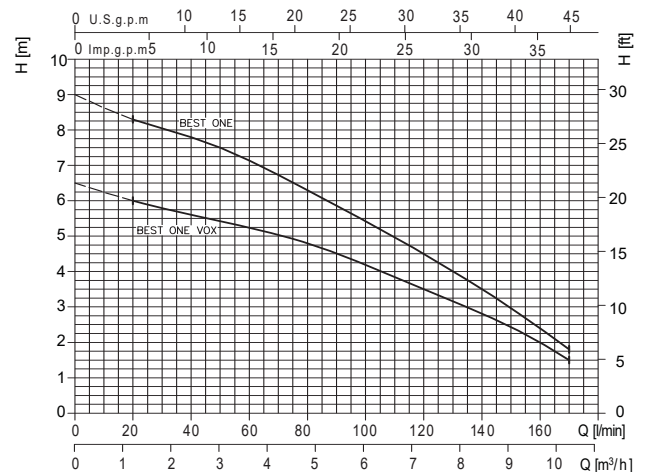

MODEL RIGHT SUBMERSIBLE WASTE WATER PUMPS



■ Features

1. Stainless steel construction.
 - All wetted parts are stainless steel.
2. Double mechanical seal in oil chamber.
 - An oil lubricated double mechanical seal with lower faces provides strong and reliable shaft sealing.
3. In built motor protection.
 - Quick action response overload or lock of single phase.
4. Vortex impeller.
 - Vortex impeller offer non-clog operation.
5. Automatic operation.
 - All single phase models are available as automatic operation with float switch.

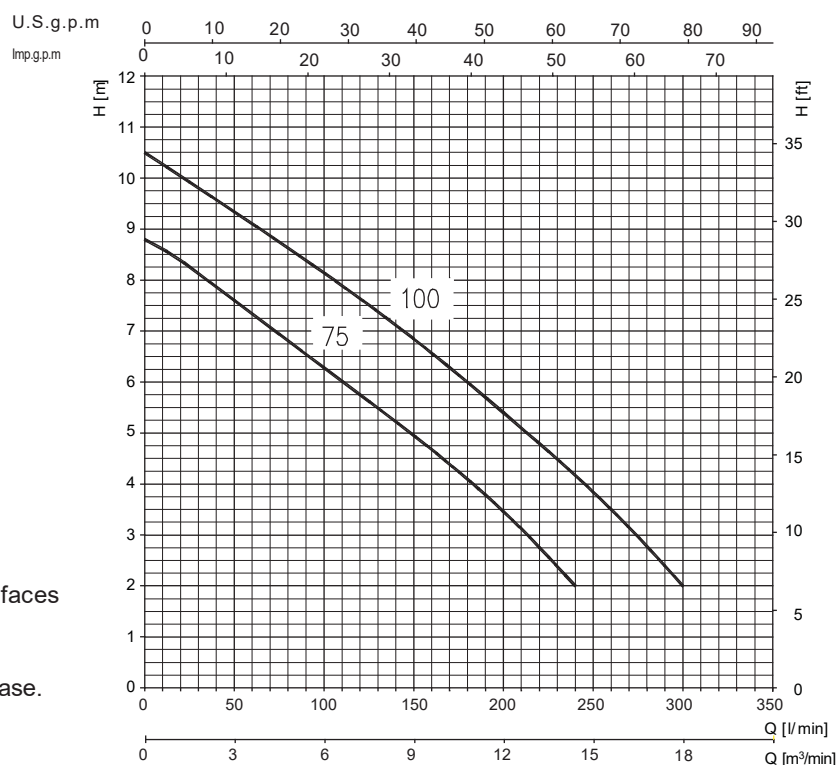

MODEL DW-DW VOX SUBMERSIBLE SEWAGE PUMPS



■ Features

1. Double mechanical seal with interposed oil chamber.
2. Reliability.
3. Vortex or single channel impeller.
4. Easy installation.
5. Completely AISI 304.
6. 10m power cable length.
7. With or without float switch.
8. Versatile with treated or flanged connection.
9. Customizable for various applications.

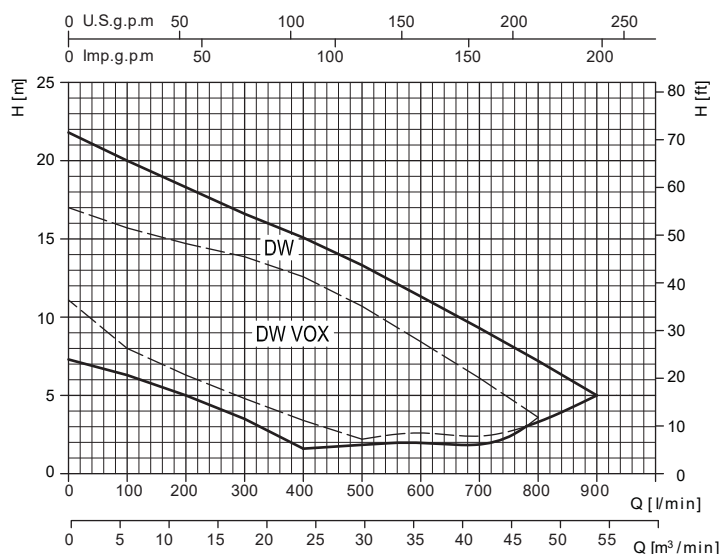

MODEL DS SUBMERSIBLE SUMP PUMPS

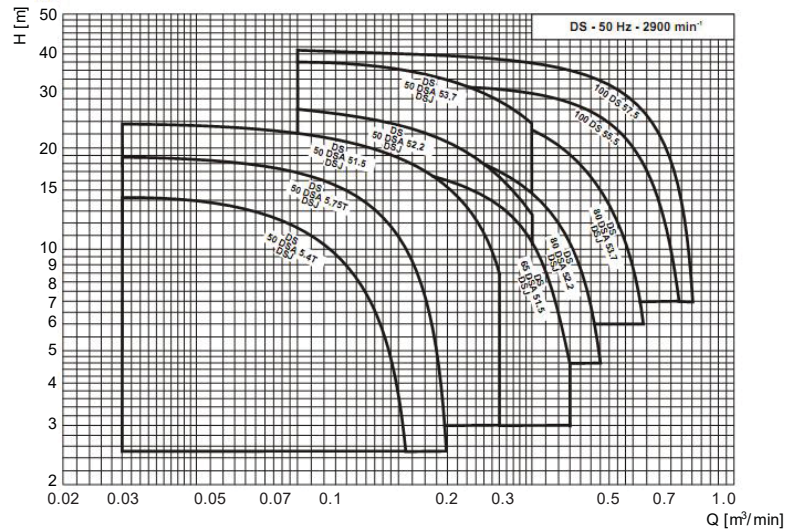

Features

1. Compact size and light weight for easy portability and minimal installation space.
2. Special dry type motor allows waste water to be handled at temperatures up to 40°C (up to 32°C with automatic alternating type).
3. Built-in motor protector precludes chance of burning due to overload, blockage or open phase.
4. Double mechanical seals for shaft sealing.
5. Both automatic and automatic alternating types available.

MODEL DVS SUBMERSIBLE SEMI-VORTEX PUMPS

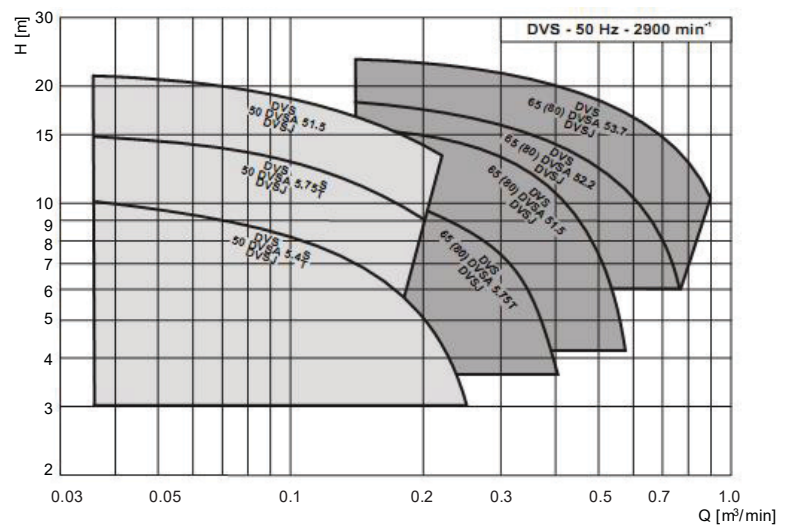

Features

1. The semi-vortex impeller offers non-clog operation and high pumping efficiency
2. Due to semi-vortex design with no strainer or close tolerance suction cover, only 3 or 4 bolts need to be removed for quick and easy maintenance.

MODEL DL SUBMERSIBLE SEWAGE PUMPS

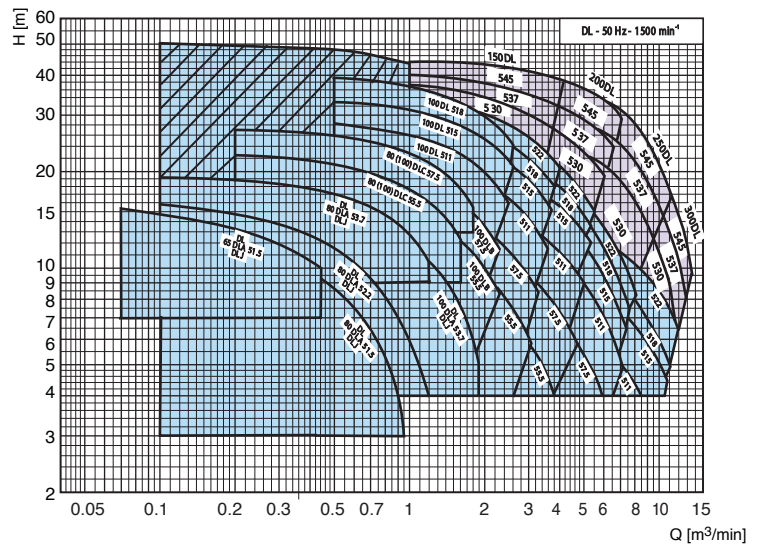

■ Features

1. Unique impeller design prevents overload under severe operation conditions. Semi-open Nonclog impeller prevents pump clog by foreign matter.
2. Minimal change in flow with variations in lift.
3. Built-in motor protector.
4. 4-pole motor with more than sufficient torque.
5. Special design with **motor IE3 (pump model DL3)**, please contact sale for more information.

MODEL DF SUBMERSIBLE SEWAGE PUMPS

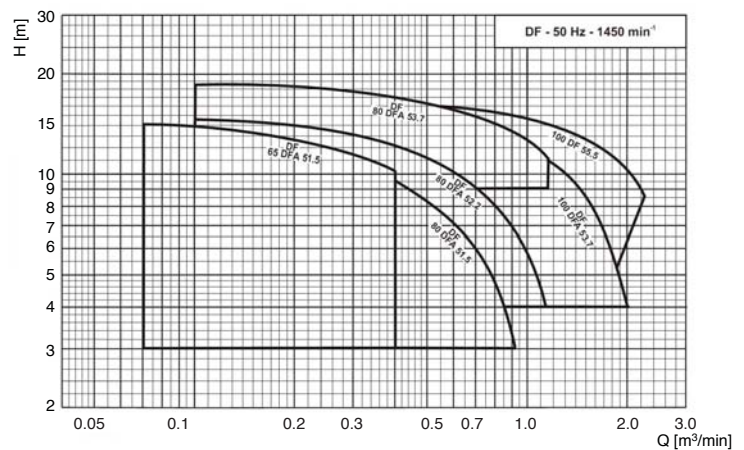

■ Features

1. Non-clog operation with “cutting” action.
 - Non-clog semi-open impeller and “cutting” action prevents clogging by fibrous matter. Models up to 3.7 kW have a chrysalis shaped suction port, while larger models have a radially grooved suction cover.
2. Robust construction.
 - Rugged cast iron construction, all fasteners of stainless steel and a 4 pole motor.
3. Double mechanical seal in oil chamber.
 - An oil lubricated double mechanical seal with lower faces of hard silicon carbide provides strong and reliable shaft sealing.
4. In built motor protection.
 - Quick acting dual response overloads provides protection against overload, lock or open phase.
5. Automatic operation.
 - All models up to 3.7 kW are available as automatic (A' type) pumps with inbuilt controls and float switches. No need for separate control panels, simply connect to power source.



PERFORMANCE CHART

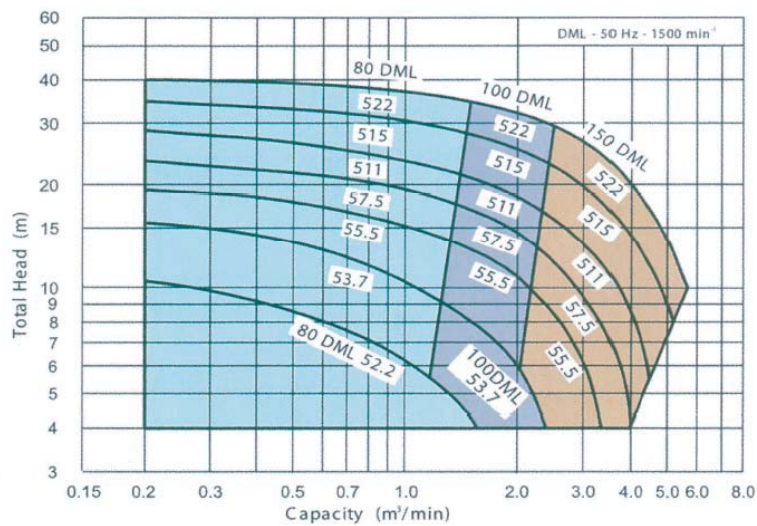

■ Features

1. Non-clog single channel impeller.
 - Non-clog single channel impeller 3” spherical passage and prevents clogging.
2. Robust construction.
 - Large diameter and short overhang shaft, rugged castiron construction, all fasteners of stainless steel and 4 pole motor drive.
3. Double mechanical seal in oil chamber.
 - An oil lubricated double mechanical seal with lower faces of hard silicon carbide provides strong and reliable shaft sealing.
4. High efficiency, Energy saving.
 - Hydraulic well designed single channel impeller gives high efficiency and saves energy.
5. Long life.
 - Short overhanged shaft, big bearings and high grade mechanical seal give longer life.
6. In built motor protection.
 - Quick acting dual response overloads provides protection against overload, lock or open phase for model 2.2 kW. Models 3.7 kW and above have miniature thermal protectors.
7. Special design with **motor IE3 (pump model DML3)**, please contact sale for more information.

PRESSURE BOOSTER PUMPS

CONSTANT SPEED PRESSURE BOOSTER UNIT

MODEL : UD3

APPLICATIONS

1. Domestic : High-rise buildings, Condominiums, Apartments etc.
2. Commercial : Office buildings, Hotels, Shopping centers etc.
3. Industrial : Factory utility, Manufacturing & processing industries applications etc.
4. Social service : Schools, Hospitals etc.

FEATURES

1. *All components are integrated* on a rugged steel base. It is *ready for use* by only connecting with supply piping and to the power source.
2. Layout is *very compact* and *much lighter* than conventional units, It occupies *lesser space* and requires *easier installation* than conventional units.
3. The flow control system which *prevents frequent start and stop* of pumps, requires only small hydro-pneumatic pressure tank and ensures *constant fresh water supply*.
4. Pumps are in parallel operation for high demand and alternating in low demand, suitable for *energy-saving*.
5. *Various options are available* on request.

Pressure tank

Air pre-charged diaphragm construction.
High reliability and suitable for portable water.

Control panel

Controls pumps operation from pressure sensor (or pressure switch) and flow switches.

Shut-off valve

Easy operation and high reliability type.
Useful for unit maintenance.

Pump

Stainless steel construction.
High reliability and long life.

Base plate

Robust construction and performs long stable unit operation.

Pressure sensor (or pressure switch)

Detects the supply pressure and feeds back to the control panel.
Weather proof, trouble free from moisture and condensation.

Discharge header

Integrated manifold type.
Compact, robust & high reliability.
High grade surface finish treatment for long life.
Available to change water discharge side.

Pressure gauge

Indicator of water pressure.
(Only for UD3-S & UD3-T)

Check valve

Spring loaded type.
Reduces water surge at pump stop.
Prolongs the unit life and performs.
Quiet operation.

Flow switch

Detects very low flow to cut off operating pump thus reducing frequency of on / off pump at low flow.

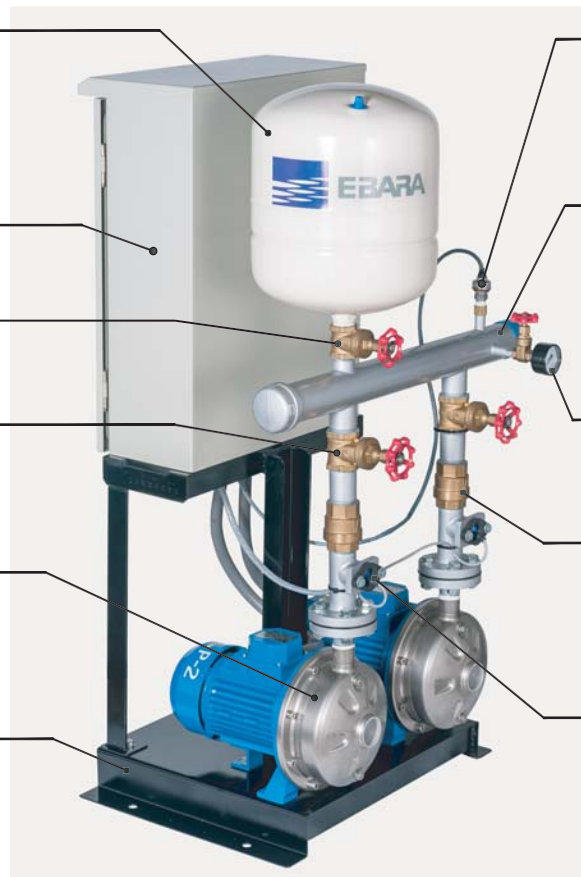

CONTROL SYSTEM

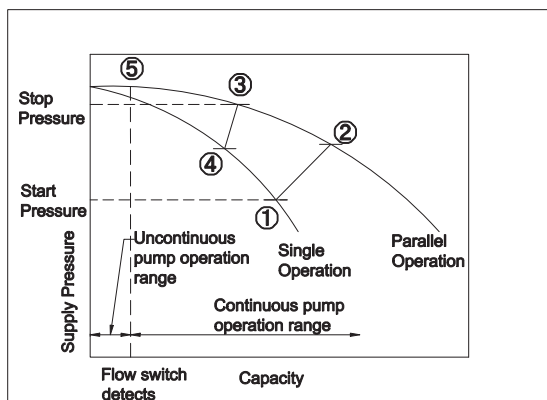

- Step 1) Both pumps are stopped when water tank is fully charged. In this condition water is supplied from the pressure tank, and water pressure in tank gradually decreases.
- Step 2) When water pressure decreases, first pump starts at pressure point ① and water is supplied from pump.
- Step 3) When more water is required and water pressure decreases to lower point ① again, second pump also starts, operation point shifts to point ② and system shifts to parallel operation.
- Step 4) When second pump starts, the timer starts to count. After that when water consumption decreases, the water pressure increases to point ③, and 60 seconds pass after second pump starts. First pump is stopped and operation point shifts to point ④.
- Step 5) When water consumption further decreases, and the flow switch detects small flow rate. Second pump stops (point ⑤). Flow switch detecting point is at small capacity point, therefore pump continuous operation range is much wider, accordingly pump start frequency is greatly decreased.

MODEL UD3 CONSTANT SPEED PRESSURE BOOSTER UNIT



SPECIFICATIONS STANDARD

Model		UD3 - S	UD3 - D	UD3 - T
Pump operation No.		1	2	3
Pump model		CDX, 2CDX & 3M	CMA, CDX, 2CDX & 3M	CMA, CDX, 2CDX & 3M
Handled liquid property		Fresh water, 0-60 degree C (Except CMA1.00 : 0-40 degree C)		
Installation		Outdoor (under roof)		
Operation system	Pump speed	Constant		
	Control	Pressure switch & flow switch*	Pressure sensor & flow switch*	Pressure switch & flow switch*
Power source		AC, Three phase, 50Hz, 380V		
Max. working pressure		6 to 10 bar G (6.1 to 10.2 kg/cm ² G) ; Refer to model		
Allowable suction pressure		Min. : -0.3 bar G (-0.3 kg/cm ² G), Max. : Refer to model		
Control panel	Starting method	DOL (Up to 5.5kW) or Star-Delta (7.5 to 11kW)		
	Construction	Weather & dust proof type / IP55		
	Operation key	Push button & selector switch type	Push button & slide switch type	Push button & selector switch type
Pressure tank	Construction	Air pre-charged diaphragm type		
	Capacity	24 liters (Standard)		
	Quantity	Refer to model		
Accessories		Control panel & support, Flow switch*, Pressure gauge* ¹ Common base, Pressure tank, Piping & valves, Electrical wiring		

OPTION

Pump model	Other models upon request
Pressure tank	Large capacity upon request
Others	On request

Note) * In case of pump model CDX90/10 & CMA1.00, flow switch is not provided.
*1 In UD3-S, UD3-T, pressure gauge is provided.

SELECTION CHART AND MODEL CODE

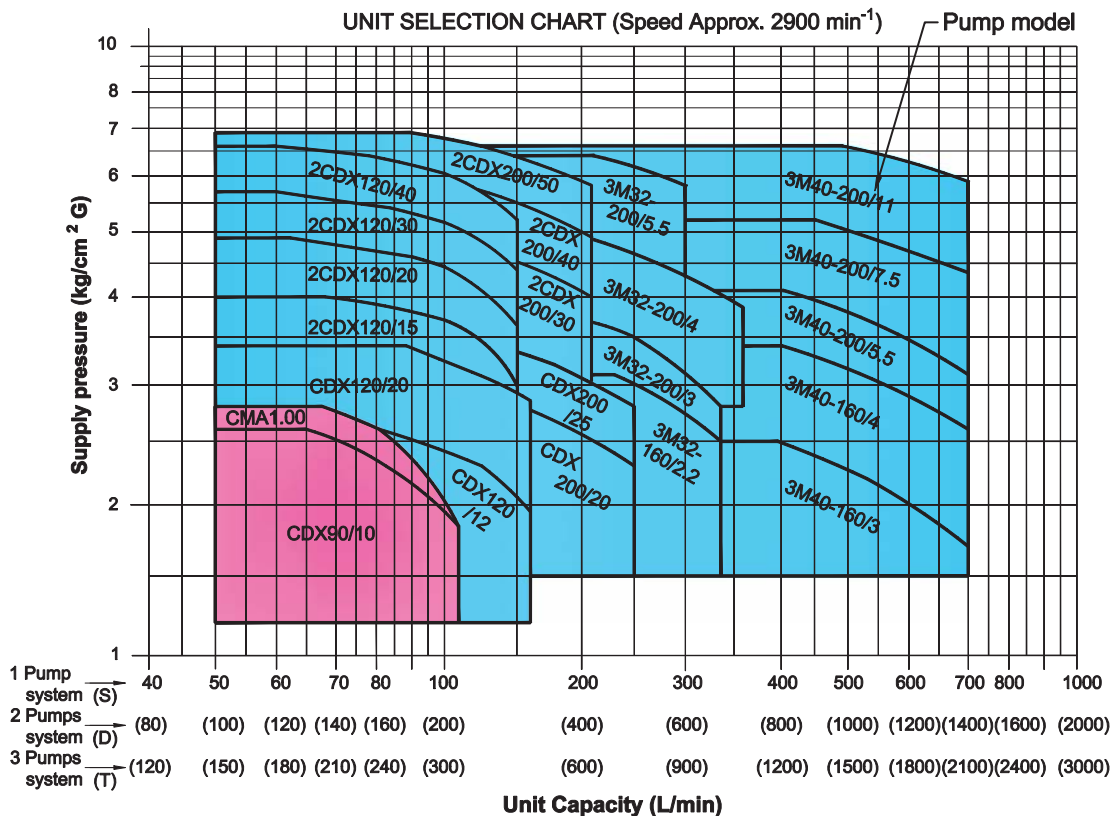

Pressure Booster Unit Model Code

UD3 - S CDX 90/10

Pump model

S : 1 Pump operation system
D : 2 Pumps operation system
T : 3 Pumps operation system

Constant speed pressure booster

Note : Models for pump CMA1.00 & CDX90/10 are UD3-D and UD3-T (2 pumps and 3 pumps operation system) only.

VARIABLE SPEED PRESSURE BOOSTER UNIT MODEL UN3

FEATURES

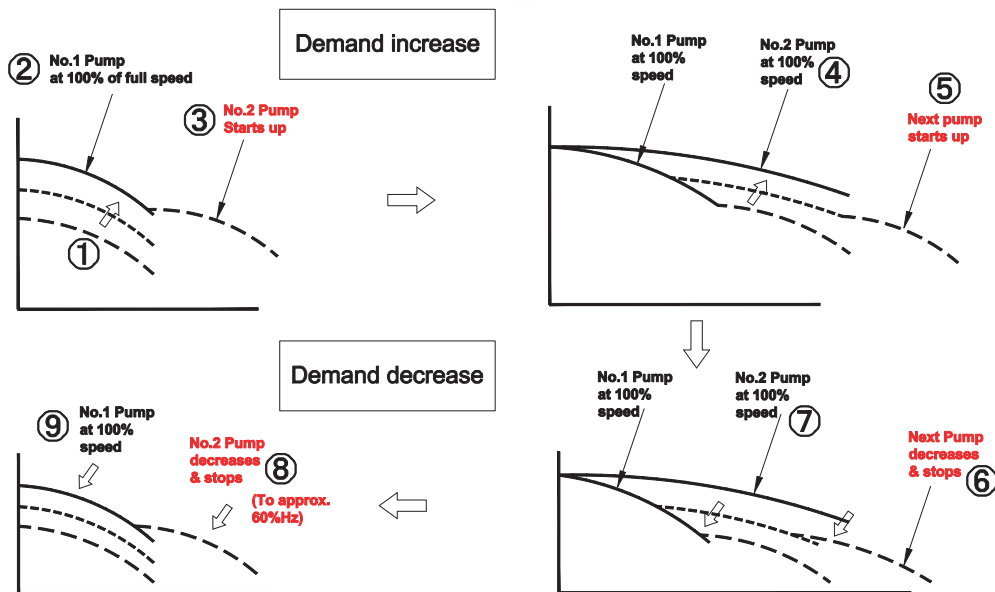
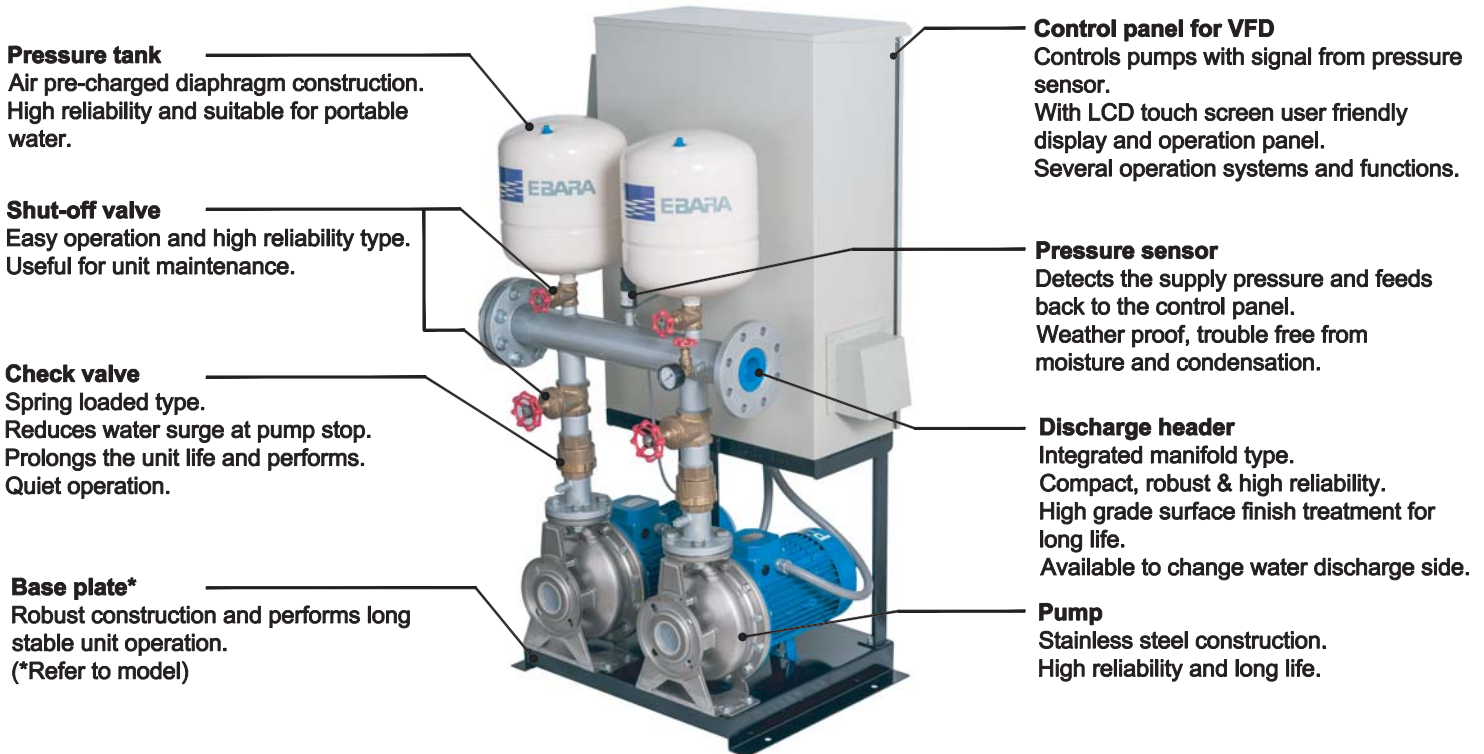

(Start ~ Water demand increase)

- ① When water is used, No.1 pump starts and increases the speed to maintain supply water pressure as water demand.
- ② No.1 pump speed becomes 100% speed (full speed).
- ③ No.2 pump starts and then increases the speed to maintain the water supply pressure.
- ④ No.2 pump speed reaches to 100% as water demand increase.
- ⑤ Next pump starts and continues the same process as like as above ③ ~ ⑤.

(Water demand decrease ~ Stop)

- ⑥ When water demand decreases, later started pump decreases the speed to maintain the supply water pressure and stops. And only No.1 & No.2 pump remain in operation.
- ⑦ Water demand decreases more, No.2 pump decreases speed.
- ⑧ Then No.2 pump stops and shifts to No.1 pump operation.
- ⑨ Water demand decreases furthermore, No.1 pump decreases speed and stops finally.

MODEL UN3A - D, -T & -F 2 TO 4 PUMPS OPERATION SYSTEM



UN3A -D ~ F : From two to four pumps with one inverter operation system, supply pressure constant with pipe loss compensation control one pump(lead pump) is variable speed controlled by inverter, the other pump is constant speed drive.

SPECIFICATIONS STANDARD

Model		UN3A - D	UN3A - T	UN3A - F
Pump operation No. / Inverter No.		2/1	3/1	4/1
Pump model		CDX, 2CDX, 3M & EVMS (Vertical Multistage)		
Handled liquid property		Fresh water, 0-60 degree C		
Installation		Outdoor (under roof)		
Operation system	Pump speed	Variable frequency control for lead pump		
	Control	Supply pressure constant with pipe loss compensation by VFD drive		
Power source		AC, Three phase, 50Hz, 380V		
Max. working pressure		8 to 10 bar G (8.2 to 10.2 kgf/cm ² G) ; Refer to model		
Allowable suction pressure		Min. : -0.3 bar G (-0.3 kgf/cm ² G), Max. : +0.3 bar G (+0.3 kgf/cm ² G)		
Control panel	Starting method	Lead pump : Soft start	Lead pump : Soft start	Lead pump : Soft start
		Lag pump : DOL or Star-Delta	Lag pumps : DOL or Star-Delta	Lag pumps : DOL or Star-Delta
	Construction	Weather & dust proof type / IP55		
	Operation key	Touch screen		
Pressure tank	Display	LCD		
	Construction	Air pre-charged diaphragm type		
	Capacity	24 liters (Standard)		
Accessories	Quantity	Refer to model		
		Control panel & support, Pressure sensor, Pressure tank Common base, Piping & valves, Electrical wiring		

OPTION

Pump model / Operation No.	Other models / 5 & 6
Pressure tank	Large capacity upon request
Others	On request

SELECTION CHART AND MODEL CODE

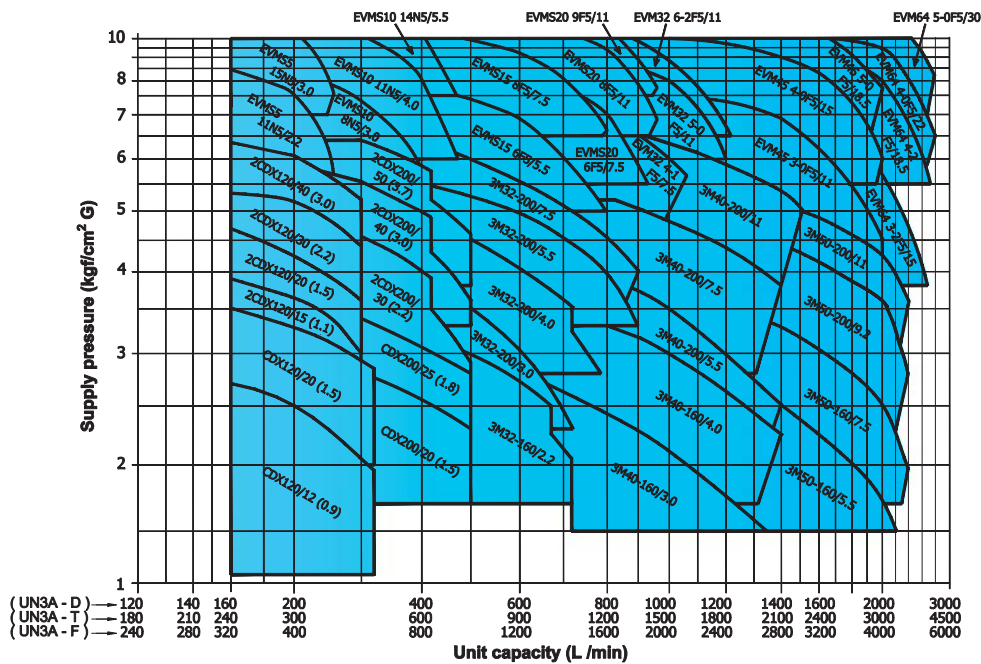

OPERATING DUTY SELECTION RANGE

Unit model	Motor output (kW)	Operating pressure range (kgf/cm ² G)	Maximum Capacity (L/min)			Unit model	Motor output (kW)	Operating pressure range (kgf/cm ² G)	Maximum Capacity (L/min)			Unit model	Motor output (kW)	Operating pressure range (kgf/cm ² G)	Maximum Capacity (L/min)		
			UN3A - D	UN3A - T	UN3A - F				UN3A - D	UN3A - T	UN3A - F				UN3A - D	UN3A - T	UN3A - F
UN3A CDX120/12	0.9	1.2 - 2.8	320	480	640	UN3A 3M32-180/2.2	2.2	1.7 - 3.3/3.1	720	1080	1440	UN3A EVMS5 11N5/2.2*	2.2	5.5 - 9.8	260	390	520
UN3A CDX120/20	1.5	2.0 - 3.6	320	480	640	UN3A 3M32-200/3.0	3.0	2.3 - 4.0	720	1080	1440	UN3A EVMS5 15N5/3.0*	3.0	7.0 - 10.0	260	390	520
UN3A 2CDX120/15	1.1	3.0 - 4.1	300	450	600	UN3A 3M32-200/4.0	4.0	2.8 - 5.0/4.4	780	1170	1560	UN3A EVMS10 8N5/3.0	3.0	4.5 - 8.1	460	690	920
UN3A 2CDX120/20	1.5	3.0 - 5.0	300	450	600	UN3A 3M32-200/5.5	5.5	3.3 - 5.9	900	1350	1800	UN3A EVMS10 11N5/4.0*	4.0	6.0 - 10.0	480	720	960
UN3A 2CDX120/30	2.2	3.6 - 5.7	300	450	600	UN3A 3M32-200/7.5	7.5	3.6 - 6.3	900	1350	1800	UN3A EVMS10 14N5/5.5*	5.5	7.5 - 10.0	480	720	960
UN3A 2CDX120/40	3.0	4.4 - 6.5	300	450	600	UN3A 3M40-160/3.0	3.0	1.5 - 2.7	1340	2010	2680	UN3A EVMS15 6F5/5.5	5.5	5.0 - 8.3	800	1200	1600
UN3A CDX200/20	1.5	1.7 - 3.0	500	750	1000	UN3A 3M40-160/4.0	4.0	1.7 - 3.6	1400	2100	2800	UN3A EVMS15 8F5/7.5*	7.5	6.5 - 10.0	800	1200	1600
UN3A CDX200/25	1.8	2.3 - 3.7	500	750	1000	UN3A 3M40-200/5.5	5.5	2.3 - 4.2	1400	2100	2800	UN3A EVMS20 8F5/7.5*	7.5	5.5 - 9.5	930	1395	1860
UN3A 2CDX200/30	2.2	2.8 - 5.0/4.5	500	750	1000	UN3A 3M40-200/7.5	7.5	2.8 - 5.2	1400	2100	2800	UN3A EVMS20 9F5/11*	11	6.5 - 10.0	960	1440	1920
UN3A 2CDX200/40	3.0	3.3 - 5.9/5.5	500	750	1000	UN3A 3M50-160/5.5	5.5	1.5 - 2.9	2200	3300	4400	UN3A EVMS20 9F5/11*	11	7.5 - 10.0	960	1440	1920
UN3A 2CDX200/50	3.7	3.8 - 6.4/6.2	500	750	1000	UN3A 3M50-200/7.5	7.5	1.7 - 3.6	2400	3600	4800	UN3A EVM32 4-1F5/7.5	7.5	4.9 - 8.3	1060	1590	2120
						UN3A 3M50-200/9.2	9.2	2.3 - 4.8	2400	3600	4800	UN3A EVM32 5-0F5/11*	11.0	6.0 - 10.0	1200	1800	2400
						UN3A 3M50-200/11	11.0	3.1 - 5.3	2400	3600	4800	UN3A EVM32 6-2F5/11*	11.0	6.5 - 10.0	1230	1845	2460
												UN3A EVM45 3-0F5/11	11.0	4.3 - 7.3	2000	3000	4000
												UN3A EVM45 4-0F5/15*	15.0	5.5 - 10.0	2000	3000	4000
												UN3A EVM45 5-0F5/18.5*	18.5	6.5 - 10.0	2000	3000	4000
												UN3A EVM64 3-2F5/15	15.0	3.8 - 7.4	2850	3975	5300
												UN3A EVM64 4-2F5/18.5*	18.5	5.5 - 9.5	2700	4050	5400
												UN3A EVM64 4-0F5/22*	22.0	5.9 - 10.0	2800	4200	5600
												UN3A EVM64 5-0F5/30*	30.0	7.1 - 10.0	2800	4200	5600

* Note : In case lead pump operation by inverter is failed and system is changed to magnetic start back up, the system supply pressure is exceeds 10 kgf/cm² G

MODEL UN3C - D, -T & -F 2 TO 4 PUMPS OPERATION SYSTEM



UN3C -D ~ F : From two to four pumps with multi-inverters operation system, supply pressure constant with pipe loss compensation control each pump is variable speed controlled by inverter, a lot of requesting functions are provided.

SPECIFICATIONS STANDARD

Model		UN3C - D	UN3C - T	UN3C - F
Pump operation No. / Inverter No.		2/2	3/3	4/4
Pump model		CDX, 2CDX, 3M & EVMS (Vertical Multistage)		
Handled liquid property		Fresh water, 0-60 degree C		
Installation		Outdoor (under roof)		
Operation system	Pump speed	Variable frequency control		
	Control	Supply pressure constant with pipe loss compensation by VFD drive		
Power source		AC, Three phase, 50Hz, 380V		
Max. working pressure		8 to 10 bar G (8.2 to 10.2 kgf/cm ² G) ; Refer to model		
Allowable suction pressure		Min. : -0.3 bar G (-0.3 kgf/cm ² G), Max. : +0.3 bar G (+0.3 kgf/cm ² G)		
Control panel	Starting method	Soft start		
	Construction	Weather & dust proof type / IP55		
	Operation key	Touch screen		
	Display	LCD		
Pressure tank	Construction	Air pre-charged diaphragm type		
	Capacity	24 liters (Standard)		
	Quantity	Refer to model		
Accessories		Control panel & support, Pressure sensor, Pressure tank Common base, Piping & valves, Electrical wiring		

OPTION

Pump model / Operation No.	Other models / 5 & 6
Pressure tank	Large capacity upon request
Others	On request

SELECTION CHART AND MODEL CODE

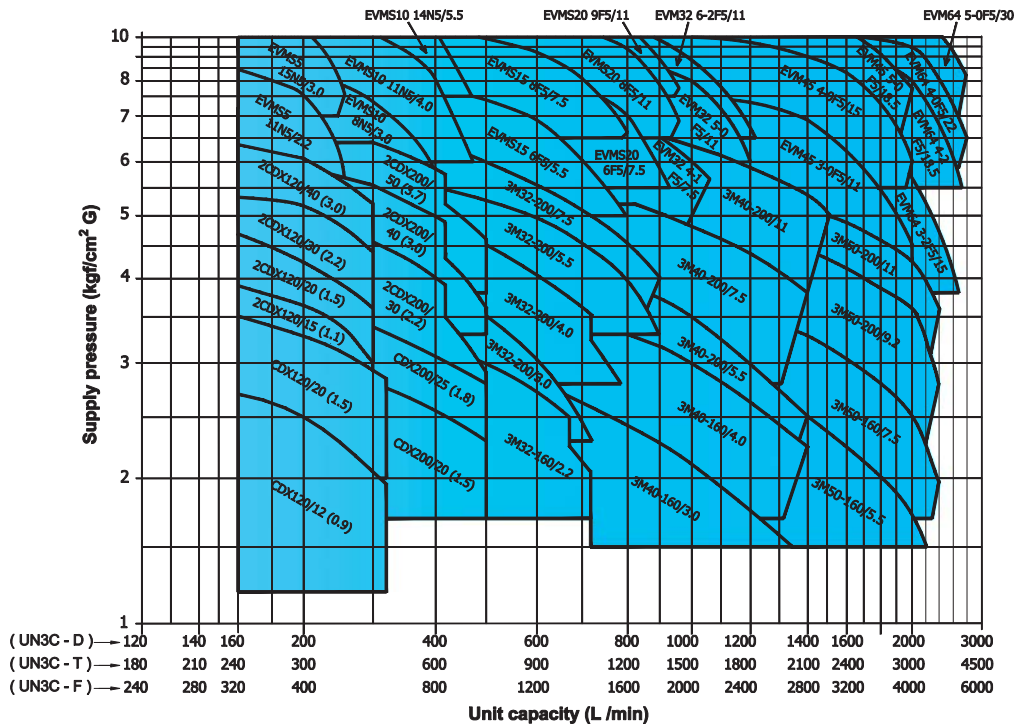

OPERATING DUTY SELECTION RANGE

Unit model	Motor output (kW)	Operating pressure range (kgf/cm ² G)	Maximum Capacity (L/min)			Unit model	Motor output (kW)	Operating pressure range (kgf/cm ² G)	Maximum Capacity (L/min)			Unit model	Motor output (kW)	Operating pressure range (kgf/cm ² G)	Maximum Capacity (L/min)		
			UN3C - D	UN3C - T	UN3C - F				UN3C - D	UN3C - T	UN3C - F				UN3C - D	UN3C - T	UN3C - F
UN3C CDX120/12	0.9	1.2 - 2.8	320	480	640	UN3C 3M32-160/2.2	2.2	1.7 - 3.3/3.1	720	1080	1440	UN3C EVMS5 11N5/2.2	2.2	5.5 - 9.8	260	390	520
UN3C CDX120/20	1.5	2.0 - 3.8	320	480	640	UN3C 3M32-200/3.0	3.0	2.3 - 4.0	720	1080	1440	UN3C EVMS5 15N5/3.0	3.0	7.0 - 10.0	260	390	520
UN3C 2CDX120/15	1.1	3.0 - 4.1	300	450	600	UN3C 3M32-200/4.0	4.0	2.8 - 5.0/4.4	780	1170	1560	UN3C EVMS10 8N5/3.0	3.0	4.5 - 8.1	460	690	920
UN3C 2CDX120/20	1.5	3.0 - 5.0	300	450	600	UN3C 3M32-200/5.5	5.5	3.3 - 5.9	900	1350	1800	UN3C EVMS10 11N5/4.0	4.0	6.0 - 10.0	480	720	960
UN3C 2CDX120/30	2.2	3.6 - 5.7	300	450	600	UN3C 3M32-200/7.5	7.5	3.6 - 6.3	900	1350	1800	UN3C EVMS10 14N5/5.5	5.5	7.5 - 10.0	480	720	960
UN3C 2CDX120/40	3.0	4.4 - 6.5	300	450	600	UN3C 3M40-160/3.0	3.0	1.5 - 2.7	1340	2010	2680	UN3C EVMS15 6F5/5.5	5.5	5.0 - 8.3	800	1200	1600
UN3C CDX200/20	1.5	1.7 - 3.0	500	750	1000	UN3C 3M40-160/4.0	4.0	1.7 - 3.6	1400	2100	2800	UN3C EVMS15 8F5/7.5	7.5	6.5 - 10.0	800	1200	1600
UN3C CDX200/25	1.8	2.3 - 3.7	500	750	1000	UN3C 3M40-200/5.5	5.5	2.3 - 4.2	1400	2100	2800	UN3C EVMS20 8F5/7.5	7.5	5.5 - 9.5	930	1395	1860
UN3C 2CDX200/30	2.2	2.8 - 5.0/4.5	500	750	1000	UN3C 3M40-200/7.5	7.5	2.8 - 5.2	1400	2100	2800	UN3C EVMS20 8F5/11	11	6.5 - 10.0	960	1440	1920
UN3C 2CDX200/40	3.0	3.3 - 5.9/5.5	500	750	1000	UN3C 3M40-200/11	11.0	3.8 - 6.5	1500	2250	3000	UN3C EVMS20 9F5/11	11	7.5 - 10.0	960	1440	1920
UN3C CDX200/50	3.7	3.8 - 6.4/6.2	500	750	1000	UN3C 3M50-160/5.5	5.5	1.5 - 2.9	2200	3300	4400	UN3C EVMS32 4-1F5/7.5	7.5	4.9 - 8.3	1080	1580	2120
						UN3C 3M50-160/7.5	7.5	1.7 - 3.8	2400	3600	4800	UN3C EVMS32 5-0F5/11	11.0	6.0 - 10.0	1200	1800	2400
						UN3C 3M50-200/9.2	9.2	2.3 - 4.8	2400	3600	4800	UN3C EVMS32 6-2F5/11	11.0	6.5 - 10.0	1230	1845	2460
						UN3C 3M50-200/11	11.0	3.1 - 5.3	2400	3600	4800	UN3C EVMS45 3-0F5/11	11.0	4.3 - 7.3	2000	3000	4000
											UN3C EVMS45 4-0F5/15	15.0	5.5 - 10.0	2000	3000	4000	
											UN3C EVMS45 5-0F5/18.5	18.5	6.5 - 10.0	2000	3000	4000	
											UN3C EVMS45 6-2F5/15	15.0	3.8 - 7.4	2850	3975	5300	
											UN3C EVMS45 4-2F5/18.5	18.5	5.5 - 9.5	2700	4050	5400	
											UN3C EVMS45 4-0F5/22	22.0	5.9 - 10.0	2800	4200	5600	
											UN3C EVMS45 5-0F5/30	30.0	7.1 - 10.0	2800	4200	5600	



▪ **Applications**

Water supply

- Domestic house etc..
- Factory utility use, Wash-down etc.
- Small office

▪ **Specifications**

- Handling liquid 0-40 °C
- Installation Indoor
- Operation system Integrated controller control
- Supply water pressure Refer to pump performance
- Power supply Single phase 220V 50Hz
- Allowable suction pressure -0.3-+0.3 bar G

■ **Features**

- Operated by integrated mechanical & electrical controller
- Compact size
- No fluctuated supply pressure at the same flow rate
- Clean water supply with no rust material (Pump in stainless steel)
- Quiet operation
- Auto display of pump operation condition

■ **Dimensions**

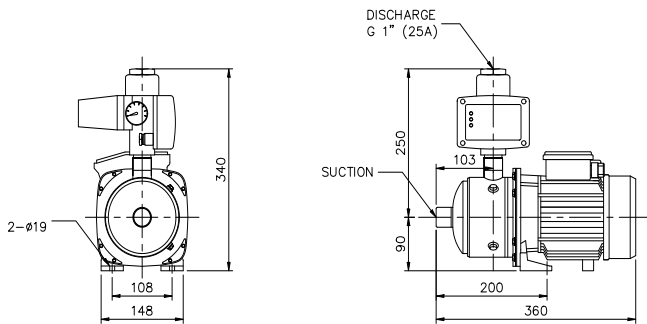

DBU1 Matrix 3-3T/0.65M
DBU1 Matrix 5-3T/0.65M

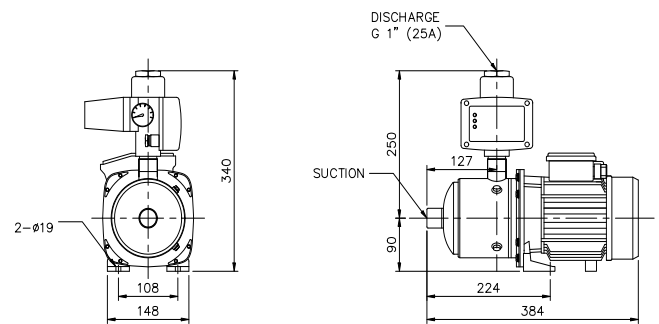

DBU1 Matrix 3-4T/0.65M
DBU1 Matrix 5-4T/0.9M

Suction connection : G1" for Matrix 3-3 and 3-4
G1-1/4" for Matrix 5-3 and 5-4

■ **Performance**

Pump Performance Chart DBU 1

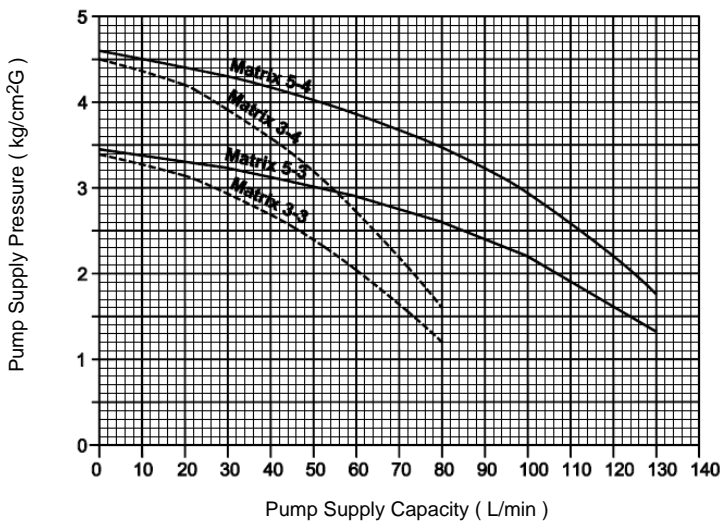

Performance table

Model	kW	Pump Supply Capacity (L/min)						
		20	30	45	60	80	100	130
		Pump Supply Pressure (kg/cm ² G)						
DBU1 MATRIX 3-3/0.65M	0.65	3.1	2.9	2.5	2.0	1.2	-	-
DBU1 MATRIX 3-4/0.65M	0.65	4.2	3.9	3.4	2.7	1.6	-	-
DBU1 MATRIX 5-3/0.65M	0.65	-	3.2	3.0	2.9	2.6	2.2	1.3
DBU1 MATRIX 5-4/0.9M	0.9	-	4.3	4.1	3.8	3.4	2.9	1.7



Pump Model : CMA



Pump Model : CDXM

Applications

- Domestic house, Condominiums, Apartments etc..
- Factory utility use, Wash-down etc.
- School, Hospital etc.

Specifications

- Handling liquid: 0-40 °C
- Installation: Indoor
- Operation system: Pressure switch
- Supply water pressure: Refer to table 1 and 2
- Power supply: Single phase 220V 50Hz
- Allowable suction pressure: -0.3 → +0.3 bar G

Features

- Robust construction with cast iron casing for CMA model
- Clean water supply with all stainless steel material for CDXM model
- Most conventional and lowest initial investment type
- No shock integrated stainless steel check valve is provided
- Enough water is stored in pressure tank

Dimensions

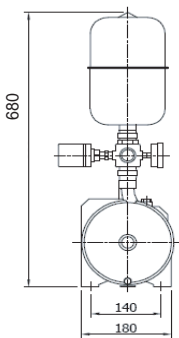

DBU2 : CMA 1.00 M
CMA 0.75 M

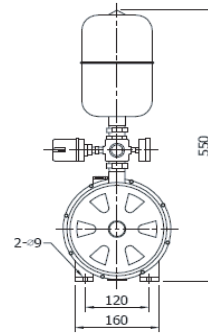
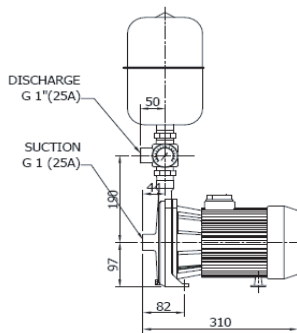

DBU2 : CDXM 70/07
CDXM 90/10
CDXM 120/12

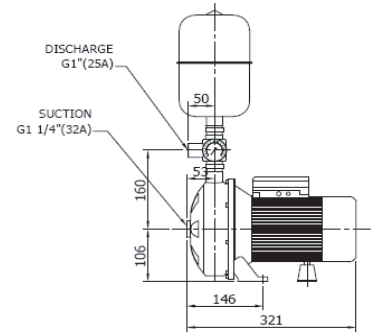

Performance

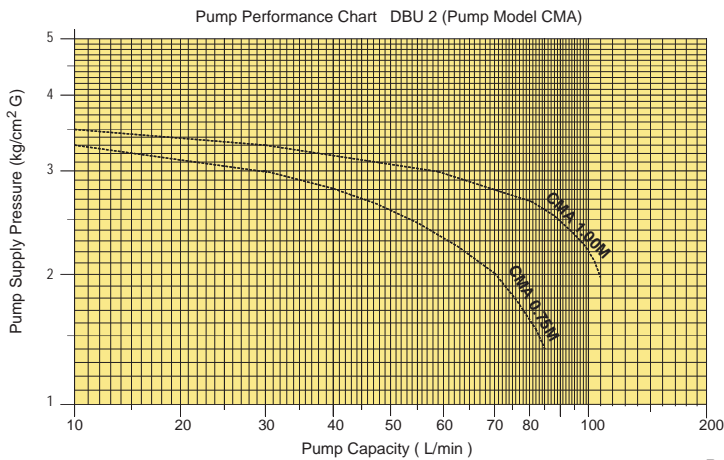

Performance Table 1

Model	Pressure Switch setting (kg/cm ² G)		kW	Pump Supply Capacity (L/min)				
	On	Off		40	60	80	100	110
				Pump Supply Pressure (kg/cm ² G)				
DBU2 CMA 0.75M	1.8	2.8	0.55	2.8	2.3	1.6	-	-
DBU2 CMA 1.00M	1.8	3.0	0.75	3.2	2.95	2.7	2.2	2

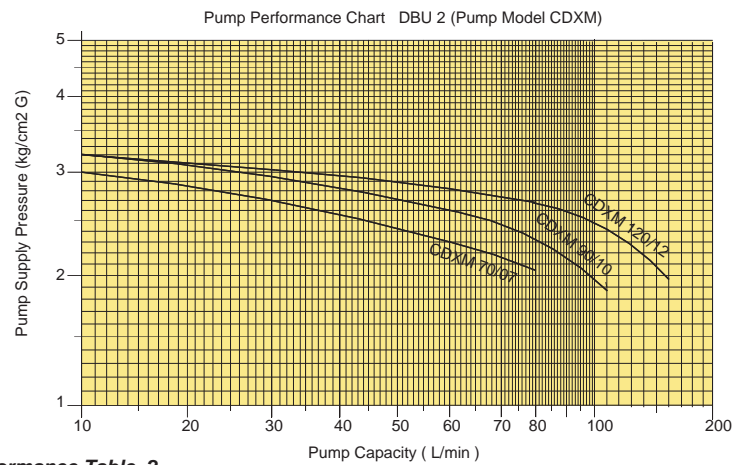

Performance Table 2

Model	Pressure Switch setting (kg/cm ² G)		kW	Pump Supply Capacity (L/min)							
	On	Off		40	60	80	100	110	120	140	160
				Pump Supply Pressure (kg/cm ² G)							
DBU2 CDXM 70/07	1.6	2.6	0.55	2.6	2.3	2.1	-	-	-	-	-
DBU2 CDXM 90/10	1.8	2.8	0.75	2.8	2.6	2.3	2.0	1.85			
DBU2 CDXM 120/12	1.8	2.8	0.9	3	2.8	2.65	2.5	2.4	2.3	2.1	1.9



■ Standard and regulation

The FFS-FFB fire fighting pressure boosting units are designed and built in compliance

- UNI EN 12845 standard ,extinguisher appliances ,water supplies for automatic system
- UNI EN 12845/10779 standard ,extinguisher systems - Hydrant networks
- 2006/42 EEC Machinery Directive
- 2006/95 CE Low Voltage Directive
- 2004/108 Electromagnetic Compatibility Directive
- European Standards :
EN60204-1 ; IEC EN60439-1 ; EN61000-6-4 ; EN61000-6-2

■ Condition for use

The FFS-FFB fire fighting pressure boosting units can be used exclusively as envisioned in the UNI EN 12845 LH, OH, HH Standard, in the automatic activation water supplies for the automatic fire fighting units in civil and industrial activities. The water conveyed must not contain solid bodies and fibres in suspension or vegetation and without aggressive and corrosive chemical substances (UNI EN 12845 8.6).

- Minimum temperature of the water conveyed is 0°C, max temperature 40°C (25°C for submersed multistage pumps)
- Environment functioning temperature is 4°÷40°C at a height not exceeding 1000 m a.s.l.
- Max. relative humidity 50% at +40°C

NB: possibly the pumping unit must be installed overhead (UNI EN 12845)

NB: each pump must have its own independent suction pipe (UNI EN 12845).

MODEL FSPA END SUCTION PUMPS

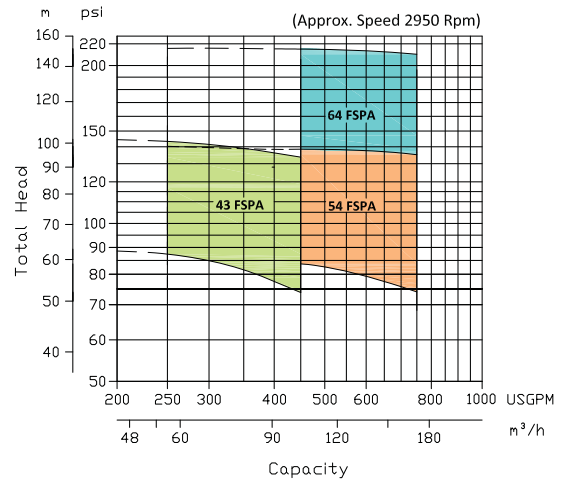

■ Features

1. Easy removal and maintenance, BPO (Back Pull Out) system allows all rotating elements to be removed without disconnecting suction and discharge pipe work.
2. Top centreline discharge, foot support under casing for maximum resistance to misalignment and distortion from pipe loads.
3. Flow rate capacity 250 up to 750 USGPM.
4. Working pressure up to 250 psi with 250 lb. ANSI Flanges.

UL File Number "EX15585"

MODEL CNPA HORIZONTAL SPLIT CASE PUMPS

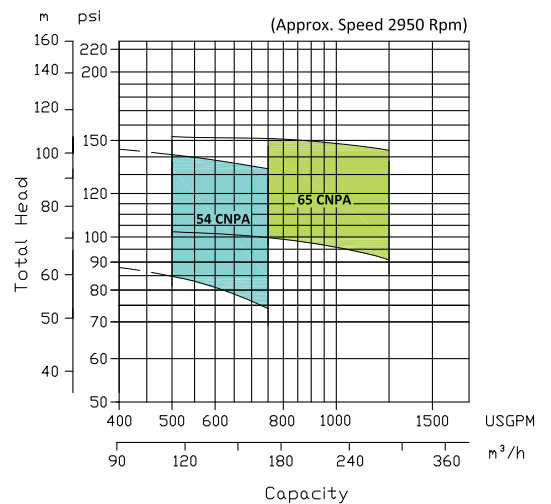

■ Features

1. Very compact design for easy of installation and permits minimum maintenance.
2. Axially split casing allows the easy removal of the top casing for inspection and service.
3. Available in horizontal or vertical configuration.
4. Available in clockwise or counter clockwise rotation to simplify pump room layout.
5. Flow rate capacity 500 up to 1250 USGPM.
6. Working pressure up to 250 psi with 250 lb. ANSI Flanges.

UL File Number "EX15584"

AFTER SALE SERVICE

In order to provide complete on sale business, After Sale Service Department is established to support for maintenance and service job.

EBARA (Thailand) has set up service team to serve customers who need urgent solution due to machine out of order. The skill team will reach to customer immediately up on requested following Ebara's policy.



Spare part overhaul

Booster pump service



Pump and motor final alignment

Pump installation at site



AFTER SALE SERVICE



Pump start up and commissioning at site

Customer training



SPARE PARTS

The original spare parts will be proposed to customer for repair or replace of the existing damaged pump. This is considered under to keep the performance as original as much as possible.

Mostly of basic spare parts such as Mechanical seal will be kept as stock in Thailand. This is considered to ensure that will be supplied to customer in short time and reasonable price.

For the other parts, please contact to EBARA (Thailand) to confirm the information.





EBARA Standard Pump Worldwide Locations

For more information on EBARA Standard Pumps and pump products, please select your country/region below.

Latin America

- Brazil*
- Mexico*
- Colombia*

Oceania

- Australia*

Middle East

- U.A.E.*
- Saudi Arabia*

Europe

- Italy*
- Spain*
- Germany*
- United Kingdom*
- France*
- Poland*

Asia

Japan / EBARA Corporation

- China*
- Taiwan*
- Turkey*
- Cambodia*
- Indonesia*
- Malaysia*
- Philippines*
- Singapore*
- Thailand*
- Vietnam*



Italy / EBARA Pumps Europe, S.p.A.



Ebara Densan (Kunshan)Mfg. Co.,Ltd., CHINA



Japan / EBARA Corporation



Ebara-Densan Taiwan Manufacturing Co.,Ltd. TAIWAN



WORKSHOP / EBARA Thailand Limited

EBARA Main Products Machinery & Equipment Group

AERO AND HYDRAULIC MACHINERY

Various centrifugal pumps
Axial-flow pumps
Mixed-flow pumps
High-pressure plunger pumps
various fans
Turbo blowers
Centrifugal and axial-flow compressors
Gas expanders
Gas turbines
Steam turbines
Water turbines
Fluid couplings
Screen cleaners
Various valves
Automatic screen cleaners
Automatic boosting units
Aerators
Power recovery equipment



FUJISAWA PLANT

CHILLERS

Turbocharged chillers
Screw chillers
Absorption-type chillers
Cold/warm water equipment
Various air conditioners
Individual airconditioning equipment
Ice storage systems

*All specification subject to change without notice.
Please send your inquiries to the authorized distributor.

AUTHORIZED DISTRIBUTOR :

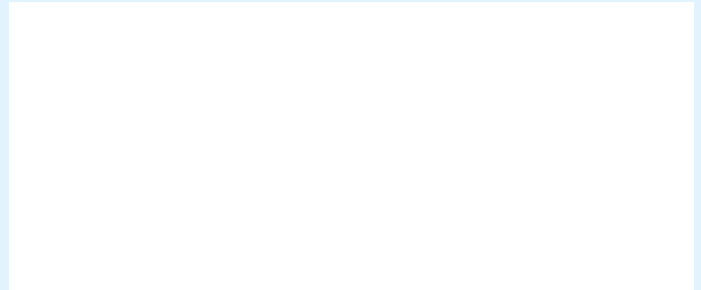

EBARA (THAILAND) LIMITED

HEAD OFFICE

125 ACME Building, 3rd Floor Petchburi Rd. Tungphayathai, Rajthevee, Bangkok 10400 Thailand.
Tel: +66 (0) 2612-0322 ~ 30 Fax: +66 (0) 2612-0331 / Email: info.etl@ebara.com / Website: www.ebara.co.th

WORKSHOP

NAVANAKORN Industrial Promotion Zone 56/19 Moo 20, Tambol Klongnueng, Amphur Klongluang, Pathumthani 12120 Thailand.
Tel : +66 (0) 2529-3643, +66 (0) 2529-3648 Fax : +66 (0) 2529-3628

PHUKET BRANCH OFFICE

Boat Lagoon Phuket
20/144 BOAT ARCADE Building, Ground floor, Moo 2, Thepkrasattri Road, Koh Kaew Subdistrict, Phuket District, Phuket 83000 Thailand.
Tel : +(66) 89-999-531-1

CHONBURI BRANCH OFFICE

4/222 Harbor Building, 12th Floor, Moo 10, Sukhumvit Road, Thung Sukla Subdistrict, Sriracha District, Chonburi 20230 Thailand.
Tel : +66 (0) 33-030-839